

**Onan**

**Commercial Mobile Power**

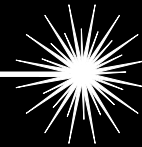

# **Installation Manual**

**Model YD PTO  
Protec Series**

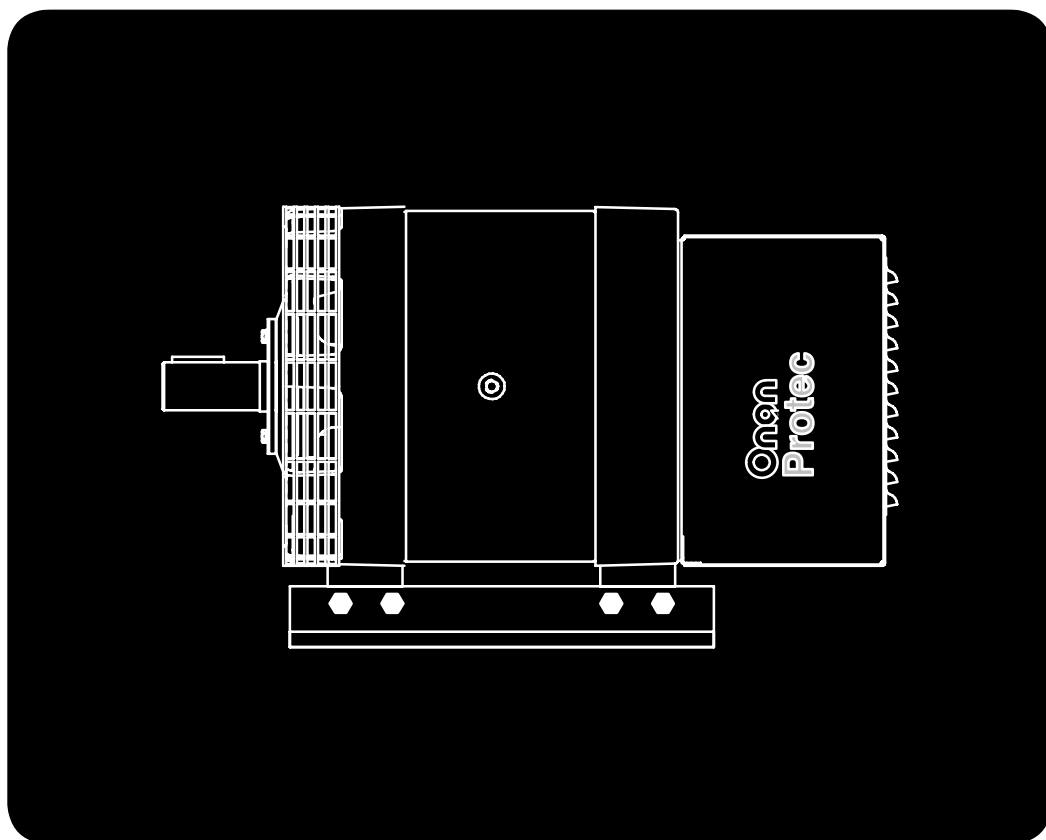

# Table of Contents

---

SECTION	TITLE	PAGE
	<b>SAFETY PRECAUTIONS</b> .....	ii, iii
<b>1</b>	<b>INTRODUCTION</b> .....	1-1
	General .....	1-1
	Generator .....	1-1
	Voltage Regulator .....	1-1
	Meter/Breaker Box .....	1-1
	Operation .....	1-1
<b>2</b>	<b>SPECIFICATIONS</b> .....	2-1
<b>3</b>	<b>PRE-INSTALLATION</b> .....	3-1
	General .....	3-1
	Generator Mounting .....	3-1
	Meter/Breaker Box Mounting .....	3-2
	PTO System Configuration .....	3-3
<b>4</b>	<b>GENERATOR MOUNTING</b> .....	4-1
	Generator Support Framework .....	4-1
	Connecting the PTO .....	4-2
<b>5</b>	<b>METER/BREAKER BOX, VOLTAGE REGULATOR MOUNTING</b> .....	5-1
<b>6</b>	<b>SYSTEM WIRING</b> .....	6-1
	General .....	6-1
	AC Wiring .....	6-1
	Output Voltage Frequency Conversion .....	6-6
<b>7</b>	<b>INSTALLATION AND WIRING DIAGRAMS</b> .....	7-1

# Safety Precautions

---

**Before operating the generator**, read the Operator's Manual and become familiar with it and the equipment. **Safe and efficient operation can be achieved only if the unit is properly operated and maintained.** Many accidents are caused by failure to follow fundamental rules and precautions.

The following symbols, found throughout this manual, alert you to potentially dangerous conditions to the operator, service personnel, or the equipment.

**⚠ DANGER** *This symbol warns of immediate hazards which will result in severe personal injury or death.*

**⚠ WARNING** *This symbol refers to a hazard or unsafe practice which can result in severe personal injury or death.*

**⚠ CAUTION** *This symbol refers to a hazard or unsafe practice which can result in personal injury or product or property damage.*

**GASOLINE AND LPG FUEL MAY BE ACCIDENTALLY IGNITED BY ELECTRICAL SPARKS**, presenting the hazard of fire or explosion, which can result in severe personal injury or death. When installing the generator set:

- Do not tie electrical wiring to fuel lines.
- Do not run electrical lines and fuel lines through the same compartment openings.
- Keep electrical and fuel lines as far apart as possible.
- Place a physical barrier between fuel lines and electrical lines wherever possible.
- If electrical and fuel lines must pass through the same compartment opening, make certain that they are physically separated by running them through individual channels, or by passing each line through a separate piece of tubing.
- DO NOT SMOKE while servicing batteries. Lead acid batteries emit a highly explosive hydrogen gas that can be ignited by electrical arcing or by smoking.



# Safety Precautions

---

## **MOVING PARTS CAN CAUSE SEVERE PERSONAL INJURY OR DEATH**

- Before starting work on the generator, disconnect batteries, negative (-) cable first. This will prevent accidental arcing.
- Keep hands, clothing, hair and jewelry away from moving parts.
- Make sure that fasteners on the generator are secure. Tighten supports and clamps, keep guards in position over fans, drive belts, etc.
- Do not wear loose clothing or jewelry while working on generators. Loose clothing and jewelry can become caught in moving parts. Jewelry can short out electrical contacts and cause shock or burning.
- If adjustment must be made while the unit is running, use extreme caution around hot manifolds, moving parts, etc.

## **ELECTRICAL SHOCK CAN CAUSE SEVERE PERSONAL INJURY OR DEATH**

- Disconnect starting battery before removing protective shields or touching electrical equipment. Use rubber insulative mats placed on dry wood platforms over floors that are metal or concrete when around electrical equipment. Do not wear damp clothing (particularly wet shoes) or allow skin surfaces to be damp when handling electrical equipment.
- Use extreme caution when working on electrical components. High voltages can cause injury or death.
- Follow all state and local electrical codes. Have all electrical installations performed by a qualified licensed electrician. Tag open switches to avoid accidental closure.
- **DO NOT CONNECT GENERATOR DIRECTLY TO ANY BUILDING ELECTRICAL SYSTEM.** Hazardous voltages can flow from the generator set into the utility line. This creates a potential for electrocution or property damage. Connect only through an approved device and after building main switch is open. Consult an electrician in regard to emergency power use.

## **GENERAL SAFETY PRECAUTIONS**

- Have a fire extinguisher nearby. Maintain extinguisher properly and become familiar with its use. Extinguishers rated ABC by the NFPA are appropriate for all applications. Consult the local fire department for the correct type of extinguisher for various applications.
- Remove all unnecessary grease and oil from the unit. Accumulated grease and oil can cause overheating and generator damage, which presents a potential fire hazard.
- **DO NOT** store anything in the generator compartment such as oil or gas cans, oily rags, chains, wooden blocks, portable propane cylinders, etc. A fire could result or the generator set operation (cooling, noise and vibration) may be adversely affected. Keep the compartment floor clean and dry.
- Do not work on this equipment when mentally or physically fatigued, or after consuming any alcohol or drug that makes the operation of equipment unsafe.

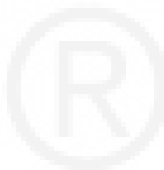



THIS PAGE INTENTIONALLY LEFT BLANK



# Section 1. Introduction

---

## GENERAL

This manual provides instructions for mounting:

- Onan AC PTO generator
- Voltage regulator box
- Meter/breaker panel

Onan does not provide the associated components that comprise a complete PTO system (power take-offs, in-cab control devices, interlock switches, PTO transmissions, etc.). Consult the manufacturer's instructions for details on non-Onan equipment.

The *Operator's* manual that accompanies each AC PTO generator describes operation and maintenance.

**⚠WARNING** *Incorrect installation, service, or replacement of parts can result in severe personal injury, death and/or equipment damage. Service personnel must be qualified to perform electrical and mechanical component installation.*

## GENERATOR

The Onan YD series AC generators are two-bearing, 1500 or 1800 rpm, 50 or 60 hertz units designed for direct drive from a power takeoff unit connected to a vehicle engine.

A centrifugal blower on the front end of the rotor shaft draws cooling air through the end bell cover, over the generator rotor, and discharges it through an outlet at the blower end.

A ball bearing at each end of the generator supports the rotor shaft. The end bell and stator housing are attached by four through-studs which pass through the stator assembly. The brushless exciter stator mounts in the end bell. The exciter rotor and its rotating rectifier assemblies mount on the rotor shaft.

## VOLTAGE REGULATOR

The voltage regulator assembly (Figure 1-2) includes the following components:

- Printed circuit board
- Voltage reference transformer

- Commutating reactor assembly
- Field circuit breaker

The voltage regulator box is mounted near the generator.

## METER/BREAKER BOX

The meter/breaker box (Figure 1-3) contains the following components:

- Voltmeter
- Ammeters
- Hour meter
- Frequency meter
- Line circuit breakers
- Marked output terminals

The generator AC output is routed to the Onan meter/switch box where amperage, voltage and frequency are displayed on a meter panel. Circuit breakers protect the generator from overcurrent conditions.

## OPERATION

The generator and voltage regulator operate as follows:

- Residual magnetism in the rotor and a permanent magnet embedded in one exciter field pole begin the voltage buildup process as the generator starts running.
- Single-phase AC voltage, taken from one of the stator windings, is fed to the voltage regulator as a reference voltage for maintaining the generator output voltage.
- The AC reference voltage is converted to DC by a rectifier bridge on the voltage regulator printed circuit board and fed into the exciter field windings.
- The exciter armature produces three-phase AC voltage that is converted to DC by the rotating rectifier assembly.
- The resulting DC voltage excites the generator rotor winding to produce the stator output voltage for the AC load.

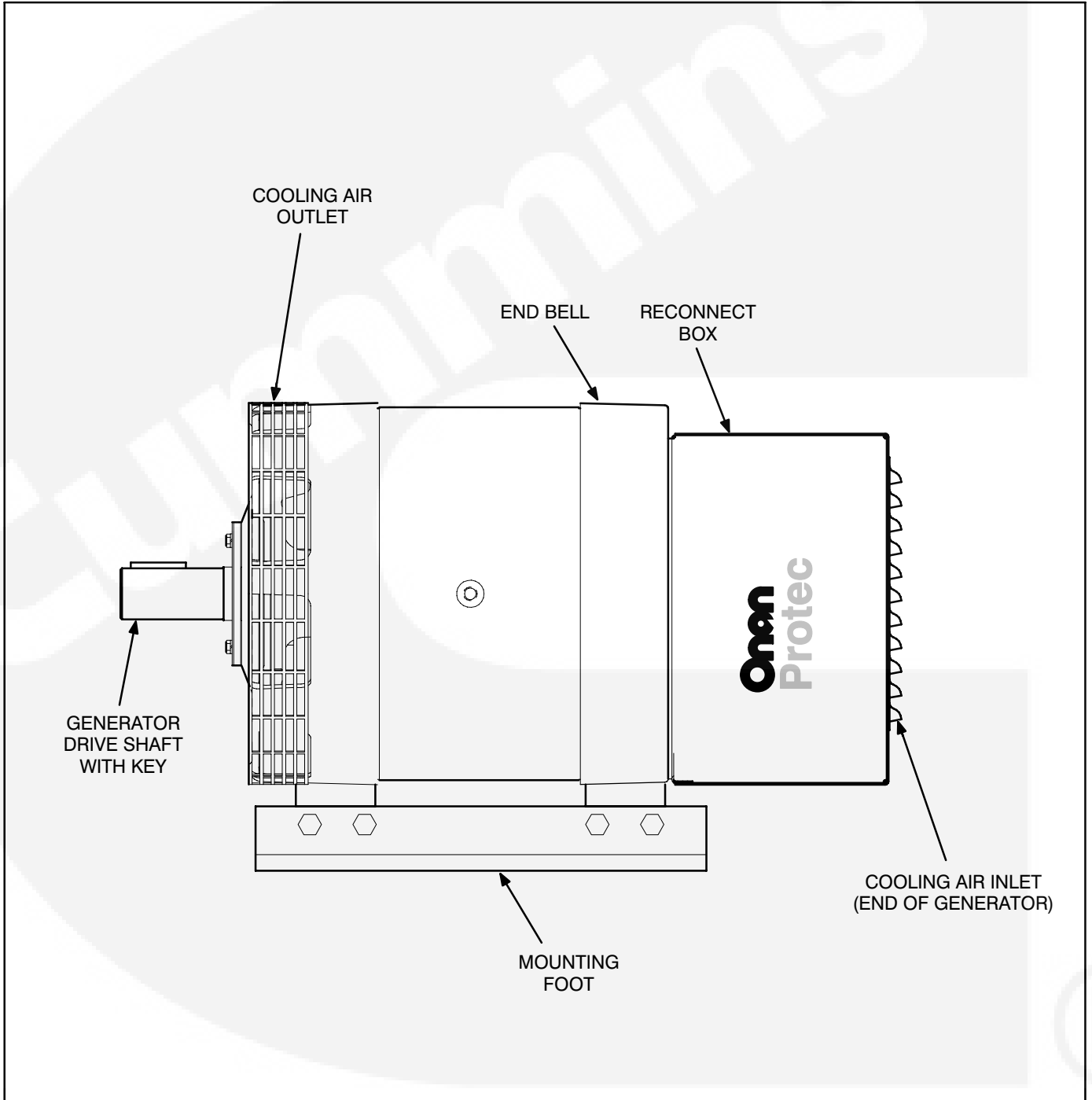

FIGURE 1-1. YD PTO GENERATOR

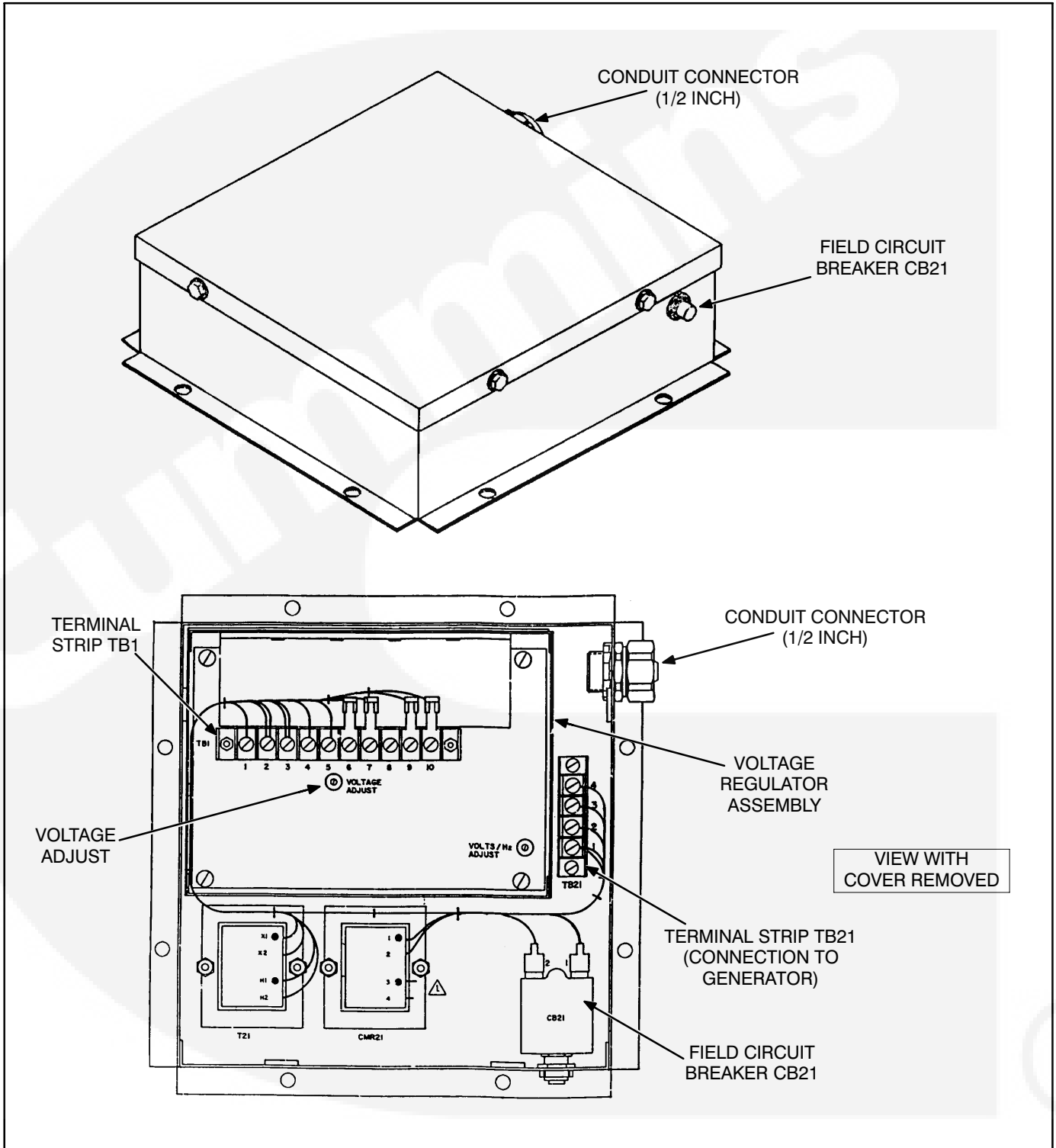

FIGURE 1-2. YD PTO GENERATOR VOLTAGE REGULATOR BOX



NOTE: AMMETER RATINGS  
VARY DEPENDING ON MODEL

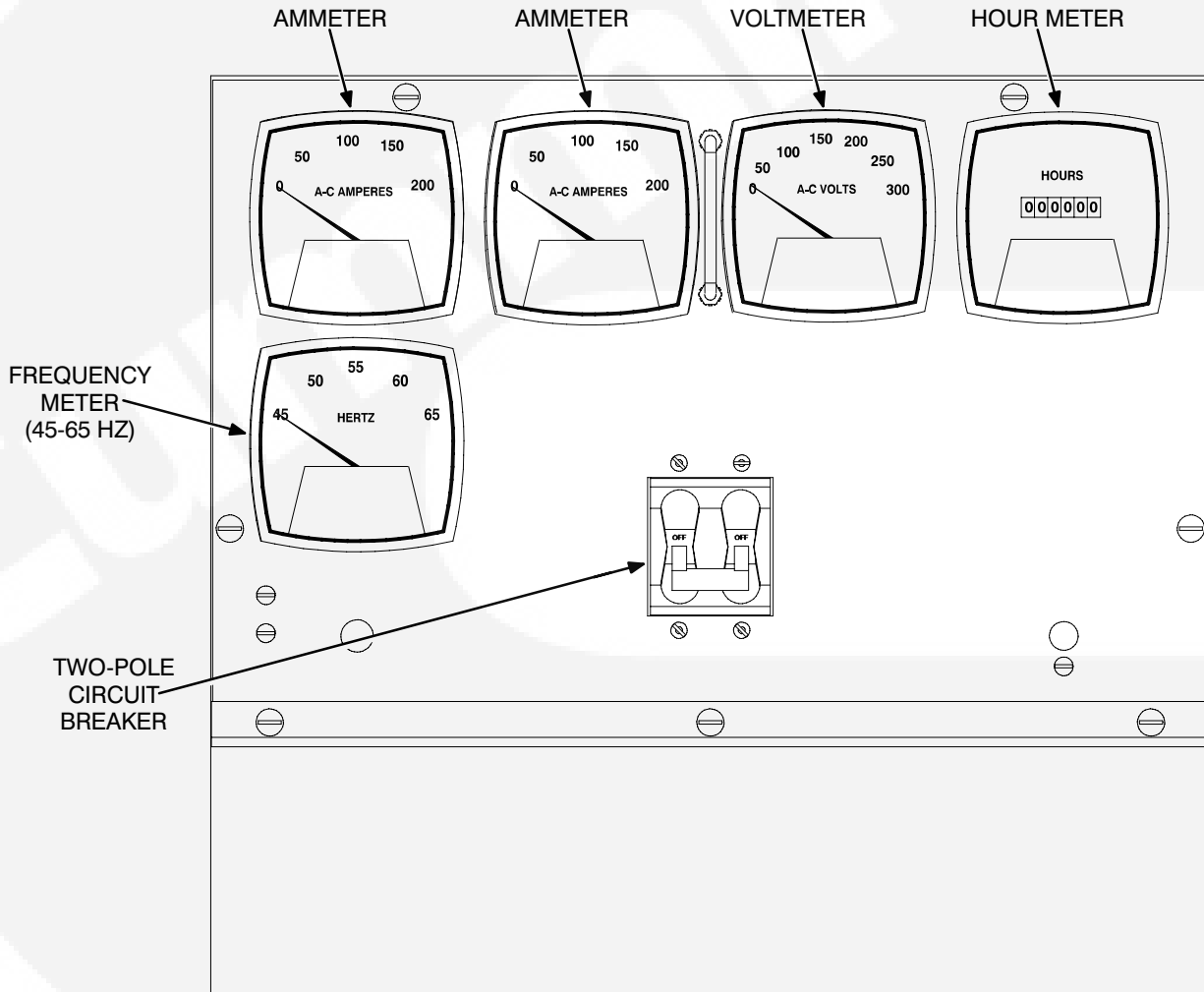

FIGURE 1-3. YD PTO GENERATOR METER/BREAKER BOX (20 kW UNIT SHOWN)

# Section 2. Specifications

---

**Design:** Revolving field: 4 pole. Drip-proof construction. Skewed stator minimizes field heating and voltage harmonics. Stator laminations welded in heavy steel frame. Dynamically balanced rotor. Windings epoxy impregnated and over-coated for environmental protection and improved cooling.

**Bearings:** 2, double sealed, prelubricated ball bearings.

**Cooling:** Direct-drive centrifugal blower.

**Reconnect Box:** End mounted. Houses output terminals and conduit connectors.

**Exciter System:** Brushless, with 8-pole stator mounted in end bell. Rectifier assemblies encapsulated for environmental protection. Permanent magnet in stator field provides reliable voltage buildup.

**Voltage Regulator:** Components include printed circuit board, voltage reference transformer, commutating reactor, field circuit breaker, voltage adjust rheostat.

**Voltage Regulator Dimensions:** 8" x 7.75" x 2.75" (203.2 mm x 196.85 mm x 69.85 mm)

**Insulation System:** Class F, per NEMA MG1-1.65 definition. Insulating varnish conforms with MIL-I-24092, Grade CB, Class 155° C.

**Electromagnetic Interference Attenuation:** Meets requirements of most industrial and commercial applications.

**Configuration:** Platform-mounted or side-mounted.

**(Optional) Meter/Breaker Box Dimensions, Circuit Breaker Ratings  
(Single Phase Units Only)**

Rating 50/60 (kW)	Circuit Breaker	L x W x H, in. (mm)
12/15	70 A, 2-pole	16.4 (418) x 4.5 (114) x 10.9 (278)
16 20	70 A, 2-pole 85 A, 2-pole	16.4 (418) x 4.5 (114) x 10.9 (278) 16.5 (419) x 10 (254) x 15 (381)
20/25	100 A, 2-pole	16.5 (419) x 10 (254) x 15 (381)
25/30	150 A, 2-pole	16.5 (419) x 10 (254) x 15 (381)
30/35	175 A, 2-pole	16.5 (419) x 10 (254) x 15 (381)

**12/15 KW GENERATOR - 1Ø**

Voltage/Frequency:  
115/230 VAC @ 50 Hz  
120/240 VAC @ 60 Hz

Phase: One

Wires: Four

Watts: 12 Kw @ 50 Hz; 15 Kw @ 60 Hz  
kVA at PF: 12.0/15.0 @ 1.0 power factor

Input Speed (RPM):  
1500 (12 Kw)  
1800 (15 Kw)

Height: 19.55 inches

Width: 15.0 inches

Length: 21.9 inches

Weight: 306 pounds

**16/20 KW GENERATOR - 1Ø**

Voltage/Frequency:  
115/230 VAC @ 50 Hz  
120/240 VAC @ 60 Hz

Phase: One

Wires: Four

Watts: 16 Kw @ 50 Hz; 20 Kw @ 60 Hz  
kVA at PF: 16.0/20.0 @ 1.0 power factor

Input Speed (RPM):  
1500 (16 Kw)  
1800 (20 Kw)

Height: 19.55 inches

Width: 15.0 inches

Length: 23.34 inches

Weight: 356 pounds

**20/25 KW GENERATOR - 1Ø**

Voltage/Frequency:  
115/230 VAC @ 50 Hz  
120/240 VAC @ 60 Hz

Phase: One

Wires: Four

Watts: 20 Kw @ 50 Hz; 25 Kw @ 60 Hz  
kVA at PF: 20.0/25.0 @ 1.0 power factor

Input Speed (RPM):  
1500 (20 Kw)  
1800 (25 Kw)

Height: 19.55 inches

Width: 15.0 inches

Length: 24.59 inches

Weight: 398 pounds

**25/30 KW GENERATOR - 1Ø**

Voltage/Frequency:  
115/230 VAC @ 50 Hz  
120/240 VAC @ 60 Hz

Phase: One

Wires: Four

Watts: 24 Kw @ 50 Hz; 30 Kw @ 60 Hz  
kVA at PF: 24.0/30.0 @ 1.0 power factor

Input Speed (RPM):  
1500 (24 Kw)  
1800 (30 Kw)

Height: 19.55 inches

Width: 15.0 inches

Length: 26.71 inches

Weight: 453 pounds

**30/35 KW GENERATOR - 1Ø**

Voltage/Frequency:  
115/230 VAC @ 50 Hz  
120/240 VAC @ 60 Hz

Phase: One

Wires: Four

Watts: 30 Kw @ 50 Hz; 35 Kw @ 60 Hz  
kVA at PF: 30.0/35.0 @ 1.0 power factor

Input Speed (RPM):  
1500 (30 Kw)  
1800 (35 Kw)

Height: 19.55 inches

Width: 15.0 inches

Length: 28.47 inches

Weight: 512 pounds

**12/15 KW GENERATOR - 3Ø**

Voltage/Frequency:  
Broad Range Voltages @ 50/60 Hz  
Phase: Three  
Wires: 12 Lead Reconnectable  
Watts: 12 Kw @ 50 Hz; 15 Kw @ 60 Hz  
kVA at PF: 12.0/15.0 @ 1.0 power factor

Input Speed (RPM):  
1500 (12 Kw)  
1800 (15 Kw)  
Height: 19.55 inches  
Width: 15.0 inches  
Length: 21.9 inches  
Weight: 306 pounds

**16/20 KW GENERATOR - 3Ø**

Voltage/Frequency:  
Broad Range Voltages @ 50/60 Hz  
Phase: Three  
Wires: 12 Lead Reconnectable  
Watts: 16 Kw @ 50 Hz; 20 Kw @ 60 Hz  
kVA at PF: 16.0/20.0 @ 1.0 power factor

Input Speed (RPM):  
1500 (16 Kw)  
1800 (20 Kw)  
Height: 19.55 inches  
Width: 15.0 inches  
Length: 23.34 inches  
Weight: 356 pounds

**20/25 KW GENERATOR - 3Ø**

Voltage/Frequency:  
Broad Range Voltages @ 50/60 Hz  
Phase: Three  
Wires: 12 Lead Reconnectable  
Watts: 20 Kw @ 50 Hz; 25 Kw @ 60 Hz  
kVA at PF: 20.0/25.0 @ 1.0 power factor

Input Speed (RPM):  
1500 (20 Kw)  
1800 (25 Kw)  
Height: 19.55 inches  
Width: 15.0 inches  
Length: 24.59 inches  
Weight: 398 pounds

**25/32 KW GENERATOR - 3Ø**

Voltage/Frequency:  
Broad Range Voltages @ 50/60 Hz  
Phase: Three  
Wires: 12 Lead Reconnectable  
Watts: 25 Kw @ 50 Hz; 32 Kw @ 60 Hz  
kVA at PF: 25.0/32.0 @ 1.0 power factor

Input Speed (RPM):  
1500 (25 Kw)  
1800 (32 Kw)  
Height: 19.55 inches  
Width: 15.0 inches  
Length: 26.71 inches  
Weight: 453 pounds

**30/40 KW GENERATOR - 3Ø**

Voltage/Frequency:  
Broad Range Voltages @ 50/60 Hz  
Phase: Three  
Wires: 12 Lead Reconnectable  
Watts: 30 Kw @ 50 Hz; 40 Kw @ 60 Hz  
kVA at PF: 30.0/40.0 @ 1.0 power factor

Input Speed (RPM):  
1500 (30 Kw)  
1800 (40 Kw)  
Height: 19.55 inches  
Width: 15.0 inches  
Length: 28.47 inches  
Weight: 512 pounds



THIS PAGE INTENTIONALLY LEFT BLANK



# Section 3. Pre-Installation

---

## GENERAL

The following factors should be considered before installing the generator, voltage regulator box and meter/breaker box:

- Location
- Adequate cooling air
- Electrical connections
- Accessibility for operation and service
- Vibration isolation

The PTO system must be designed, configured and installed properly for the Onan YD PTO AC generator to operate correctly. Each PTO installation is different, depending on the manufacturer's requirements. PTO operating considerations as they affect the Onan generator are described later in this section.

**⚠️ WARNING** *Incorrect installation, service, or parts replacement can result in severe personal injury, death, and/or equipment damage. Service personnel must be qualified to install electrical and mechanical components.*

## GENERATOR MOUNTING

Generator mounting considerations include:

- **Generator support area:** The mounting framework must be able to support the weight of the generator. Generator weight is found in Section 2 of this manual. The vehicle manufacturer and the installer must provide a structurally sound support area.
- **Generator mounting hole configuration:** The mounting area must be able to accept the

mounting hole arrangement found on the generator. Generator mounting holes are illustrated in Section 7 of this manual.

- **Generator ventilation:** The mounting area must have sufficient ventilation for the generator's cooling requirements. An area with minimal dust and dirt is preferable. The generator compartment must not admit dirt, rocks, water or slush. The entrance of dust and salt into the compartment must be minimized. Baffles may be needed to protect certain areas.

**NOTE: Avoid recirculation of ventilation air. Configure the generator ventilation so that only fresh air is circulated through the generator.**

- **Protection from exhaust heat:** The generator must be protected from excess heat: for this reason, it should not be mounted close to the vehicle muffler or exhaust area unless it is absolutely necessary. Use a heat shield if the muffler and generator are to be mounted close together.
- **Generator mounting hardware:** Along with a mounting framework for the generator, hardware for connecting the generator to the PTO output should be considered. Components that must be selected typically include:
  - A keyed coupler to connect the generator shaft to the PTO output
  - U-joints for the PTO-generator coupling
  - A sliding coupler element to prevent thrust load on the front bearing of the generator
  - A shear-limiting coupler to prevent damage to the transmission or generator due to a seized bearing or high starting torque



## METER/BREAKER BOX MOUNTING

Meter/breaker enclosure mounting considerations include:

- **Meter/breaker box mounting hole configuration:** The mounting area must be able to accept the mounting hole arrangement found on the control box. Section 5 of this manual describes meter/breaker box mounting.
- **Meter/breaker box vibration mounting:** Rubber/plastic vibration mounts should be used between the box and the mounting framework. The box must be protected from potentially harmful vibration.
- **Meter/breaker box protection:** The box should be mounted in an area that is protected from the elements: rain, dust, etc. can harm electrical components.

Figure 3-1 shows a typical meter/breaker box installation.

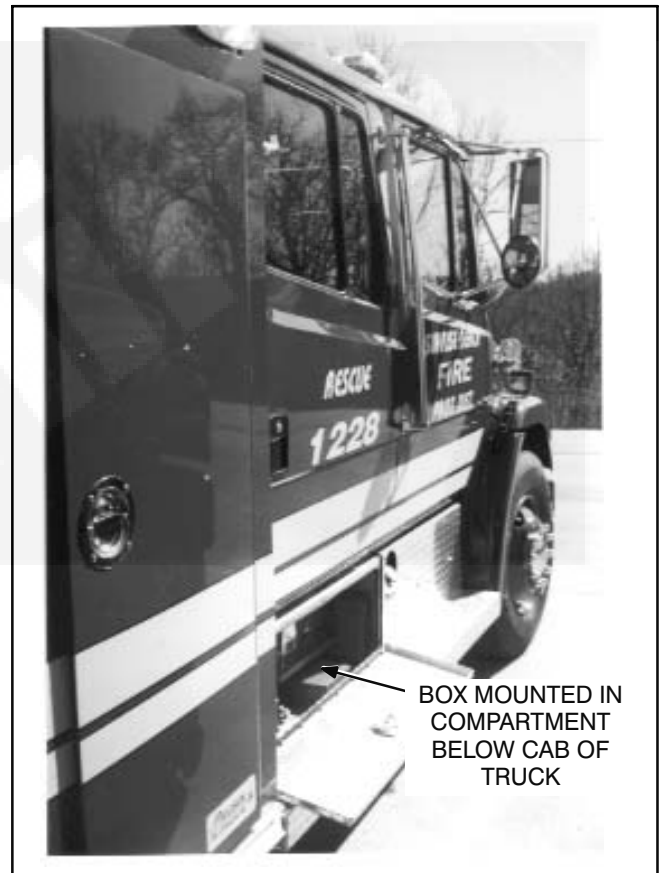

FIGURE 3-1. METER/BREAKER BOX MOUNTING

## PTO SYSTEM CONFIGURATION

The installation and operation of a vehicle-mounted PTO system are outside the scope of this manual. However, any PTO system must be configured bearing these considerations in mind:

### Control System

The control system can have as many or as few automated elements as is necessary. Controls may be mounted inside or outside the vehicle cab, in any location. Figure 3-2 illustrates some typical control mounting locations.

### Interlocks

The PTO control system should have interlocks to

**⚠WARNING** Emergency brake and/or transmission interlocks must be provided to prevent PTO operation while the vehicle is in motion. Do NOT operate generator while vehicle is moving or in gear. Severe equipment and property damage and personal injury may result.

keep the PTO from being engaged under the following circumstances:

- When the vehicle is moving (emergency brake interlock)
- When the vehicle is in gear (transmission neutral interlock)
- If the engine speed is higher than the speed required to run the generator (engine governor interlock)

Other interlocks may be necessary depending on the application and the control system selected. Consult the PTO and control systems' manuals for guidelines. Figure 3-3 is a block diagram of a typical PTO/generator system, showing how the Onan components fit into a standard configuration.



TYPICAL IN-CAB PTO CONTROL

PTO ON-OFF SWITCH

FIGURE 3-2. EXAMPLES OF PTO CONTROL PANELS



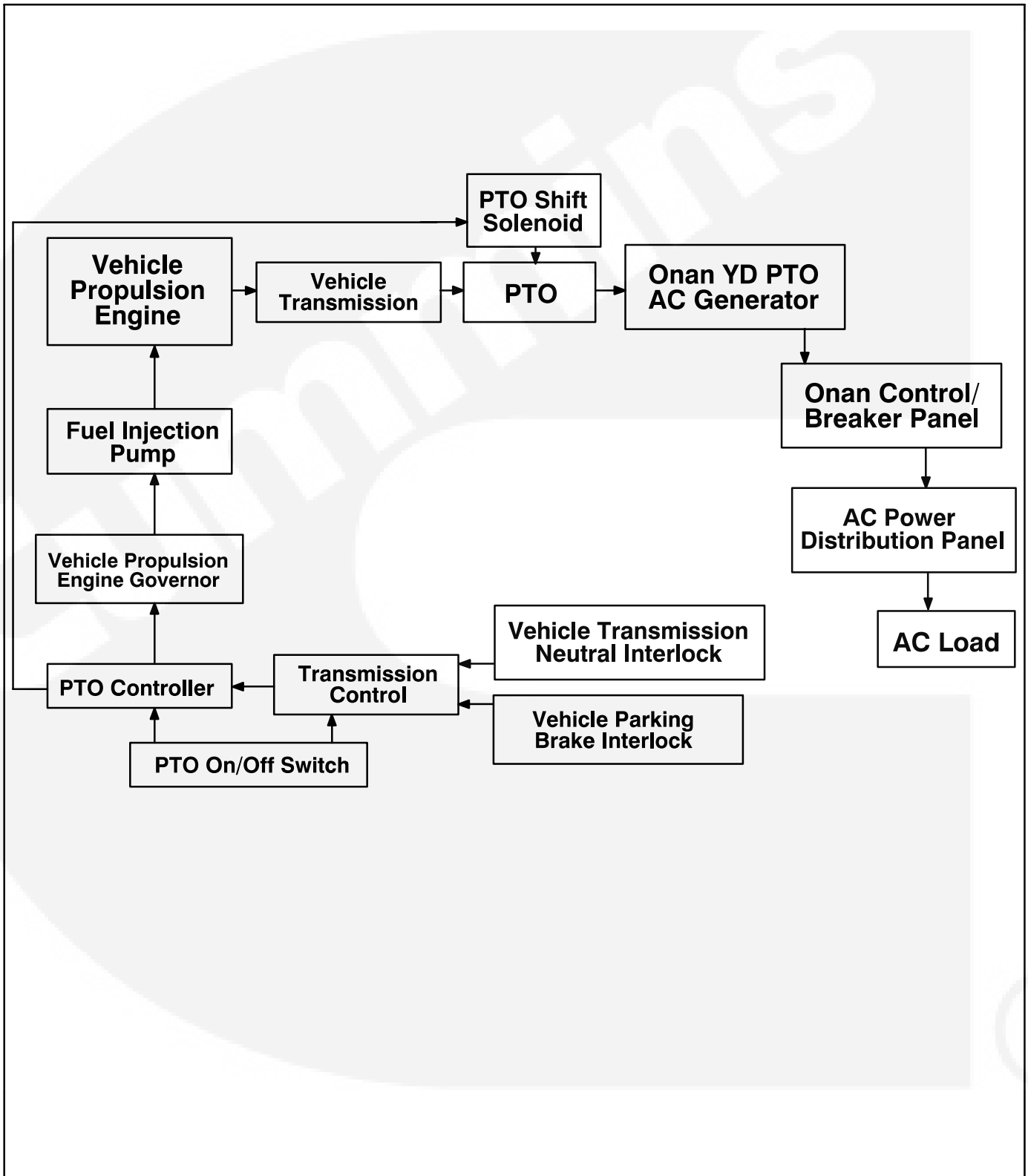

FIGURE 3-3. PTO GENERATOR SYSTEM BLOCK DIAGRAM

# Section 4. Generator Mounting

---

## GENERATOR SUPPORT FRAMEWORK

The generator must be mounted on a framework that is capable of supporting its weight subjected to road shocks. Generator weights are listed in Section 2 of this manual.

Normally, a framework is constructed underneath the vehicle chassis, located in line with the PTO transmission. A tubular steel framework cradles the PTO generator from the main frame rail at the right hand side of the vehicle.

Points to consider when constructing such a framework include:

- **Clearance:** Allow as much clearance as possible between the generator framework and the road, especially if travel over rough surfaces or grass and brush is likely.
- **Frame support:** The frame support must be reinforced to avoid system resonances at generator running speed (and multiples of running speed).

- **Frame alignment:** Alignment is critical to generator operation. Side loads due to misalignment could provide a source for system resonance at multiples of running speed.

See Section 7 of this manual for an outline drawing of the generator showing its mounting holes, dimensions, and air inlet and outlet locations.

Make sure that the air “inlet louvers” of the reconnect box access cover point downward. The access cover can be rotated in any direction to correctly position the inlet louvers to the installed position of the generator.

Note that the standard under-chassis installation described in this manual presents little likelihood of operator contact with the PTO or the generator. However, other applications may mean that the generator is accessible. In such cases, proper guards and barriers to rotating components must be installed. Failure to install adequate guards may lead to severe injury or death from contact with moving parts. Contact Onan application engineers before attempting any other mode of installation than that which is described in this Manual.

**⚠WARNING** If the PTO generator is accessible to the operator or other personnel, guards must be installed around rotating parts to prevent severe injury or death. Contact Onan application engineers before attempting any installation other than described in this Manual.



## CONNECTING THE PTO

A standard keyed coupling should be used to connect the generator driveshaft with the PTO output shaft. The drive shaft yoke is coupled to the generator's straight shaft with a four-bolt steel flange coupling keyed to the shaft. Figure 4-1 shows the generator shaft and key. A full outline drawing of the generator is found in Section 7 of this manual.

Points to consider when connecting the PTO AC generator to the driving source:

- **Generator inertia load:** Note that the entire drive train including the generator shaft must be designed to absorb the starting torque due to the inertia of the generator rotor. A torsional drawing showing the inertia, weight, stiffness and length of each part of the generator rotor is included in Section 7 of this manual.
- **Generator driveshaft takeup section:** Note that the drive shaft should have a slider bar, splined take-up section or other variable-length coupling, to take up slight drive shaft length variances, and to prevent thrust load on the front bearing.
- **Generator driveshaft shear limiter:** A shear limiting device may be needed in the coupling to prevent damage to the transmission or generator due to a seized bearing or high starting torque.
- **Driveshaft alignment:** Side loads due to misalignment could provide a source for running speed vibration. Alignment is critical on the YD PTO generator.

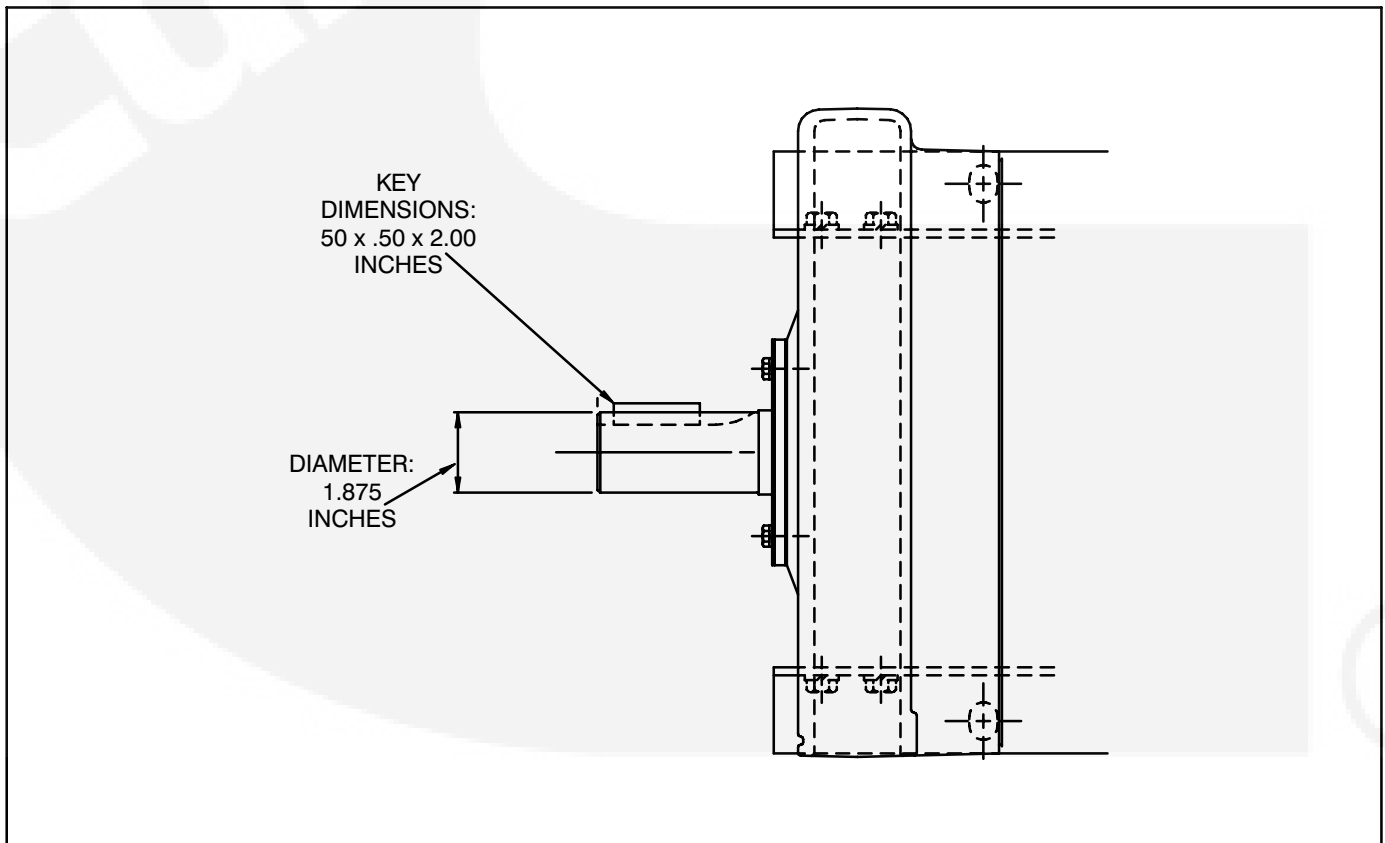

FIGURE 4-1. DETAIL OF GENERATOR SHAFT AND MOUNTING KEY

# Section 5. Meter/Breaker Box, Voltage Regulator Box Mounting

Mounting the voltage regulator box and the optional meter/breaker box supplied with the Onan YD PTO AC generator is a relatively uncomplicated process. The boxes are bolted to a convenient surface which is:

- Protected from the elements
- Convenient to the electrical load or load panel

See Section 3 of this manual (Pre-Installation) for factors regarding the selection of the location for the meter/breaker box.

Mounting the two boxes simply involves:

- Selecting the mounting area
- Measuring the mounting area
- Drilling the mounting holes
- Installing bolts and nuts to hold the box in place

**⚠WARNING** Before drilling holes, check to make sure no electrical or fuel lines run behind the area. Severe personal injury or death could result.

See Section 7 of this manual for drawings of the voltage regulator box and of the two sizes of the meter/breaker box, with dimensions and the locations of their mounting holes.

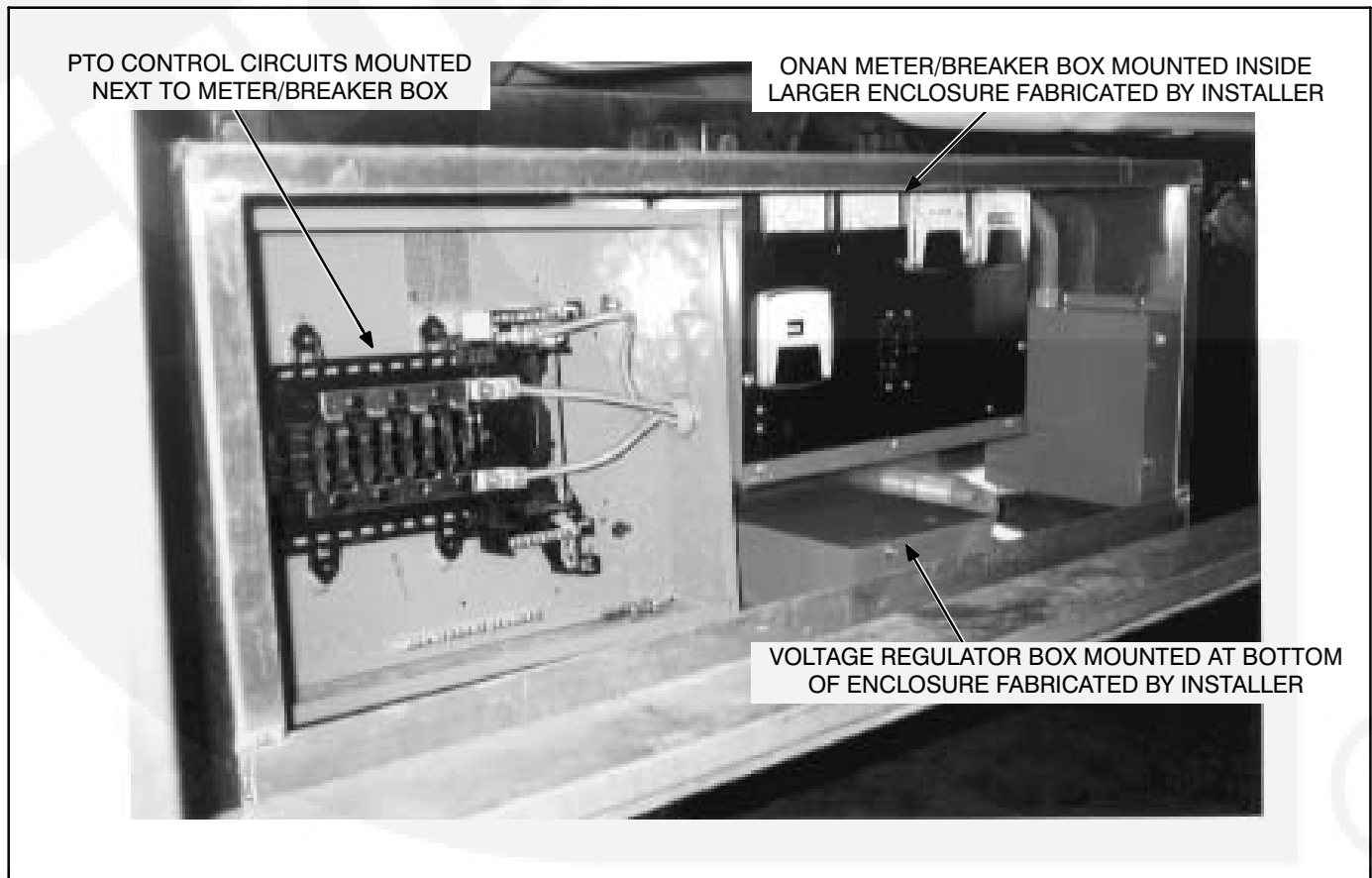

FIGURE 5-1. ONAN METER/BREAKER PANEL MOUNTING



THIS PAGE INTENTIONALLY LEFT BLANK



# Section 6. System Wiring

---

## GENERAL

This section provides the procedure that is used to connect the AC electrical system of the YD PTO AC generator.

Connecting the generator AC electrical system involves:

- Generator voltage connections
- Load connection
- Wiring of voltage regulator box
- Wiring of optional meter/breaker box (single phase, series 3-wire configuration only)

Local regulations often require that wiring connections be made by a licensed electrician, and that the installation be inspected and approved before operation. All connections, wire sizes, materials used, etc. must meet local electrical codes.

**⚠️WARNING** *Improper wiring can cause a fire or electrocution, resulting in severe personal injury or death and/or property and equipment damage.*

Before using the generator, verify that all electrical connections are secure, and that all wiring is complete. Replace and secure any access panels that have been removed during installation. Check that the load cables from the generator are properly connected.

Wiring methods must be in accordance with applicable codes, such as the National Electrical Code (NFPA No. 70).

## AC WIRING

### Generator Voltage Connections

The YD PTO AC generator can be configured for the voltages shown in the Reconnection Diagrams in *Section 7*. Most of these voltages must be reconnected by the installer to give the voltage required by the installation. Before shipping, the factory tests the generator output by connecting the generator to produce a particular test voltage. The generator may be connected at the factory to produce a specified voltage per customer order. The installer must always check the stator lead terminal block connections and perform any necessary reconnect to obtain the voltage desired.

When installing the optional meter/breaker box, the generator leads must be routed through current transformers for proper meter operation. The transformers are labeled CT1 and CT2. Refer to Figures 6-2 and 6-3 to identify the output leads that must be routed through each correct transformer.

Use the electrical schematic supplied with your generator when actually performing load connections.

**⚠️CAUTION** *Reconnecting factory connected generators to lower voltages can reduce set ratings, and also render line circuit breakers too small. Consult with your distributor before performing reconnection for a different voltage.*



---

## AC Connections

**⚠WARNING** *Incorrect installation, service or replacement of parts can result in severe personal injury, death and/or equipment damage. Service personnel must be qualified to perform electrical and/or mechanical component installation.*

See Figures 6-1, 6-2, and 6-3 for typical connections. Once the generator, voltage regulator box and control/meter box are mounted, perform the following steps:

1. Cut two holes into the side of the reconnect box, one for the load wires and the other for the voltage regulator leads.
2. Cut and fit flexible watertight conduit between:
  - a. The generator and the load panel or the optional control/meter box.
  - b. The generator and the voltage regulator box.
3. Pass the load wires and the voltage regulator leads through the conduit and connect to the appropriate terminals. Use 16 gauge (stranded) wire for the voltage regulator circuit. Wiring diagrams for the meter/breaker panels, generator, and voltage regulator are found in *Section 7*.
4. Make sure that all terminal connections are clean and tight.

To prevent corrosion, cover all terminals with a non-conductive, corrosive protectant sealer.

## Grounding

Typical requirements for bonding and grounding are given in the National Electrical Code, Article 250. All connections, wire sizes, etc. must conform to the requirements of the electrical codes.

**⚠WARNING** *Faulty grounding can lead to fire or electrocution and severe personal injury or death. Grounding must be in accordance with applicable codes.*

## Load Balancing

**Three phase:** When connecting loads to three phase generators, balance the loads so the current flow from each line terminal (L1, L2, and L3) is about the same. This is especially important if both single phase and three phase loads are connected. Any combination of single phase and three phase loading can be used as long as each line current is within 10 percent of median value and no line current exceeds the nameplate rating of the generator.

**Single phase:** For single phase generators connected in a “series 3-wire” configuration, the maximum loading of either branch circuit (L1 - L0 or L2 - L0) should not exceed 50 percent of the generator rated load. In addition, imbalance between branch circuits should not exceed 10 percent of rated load.



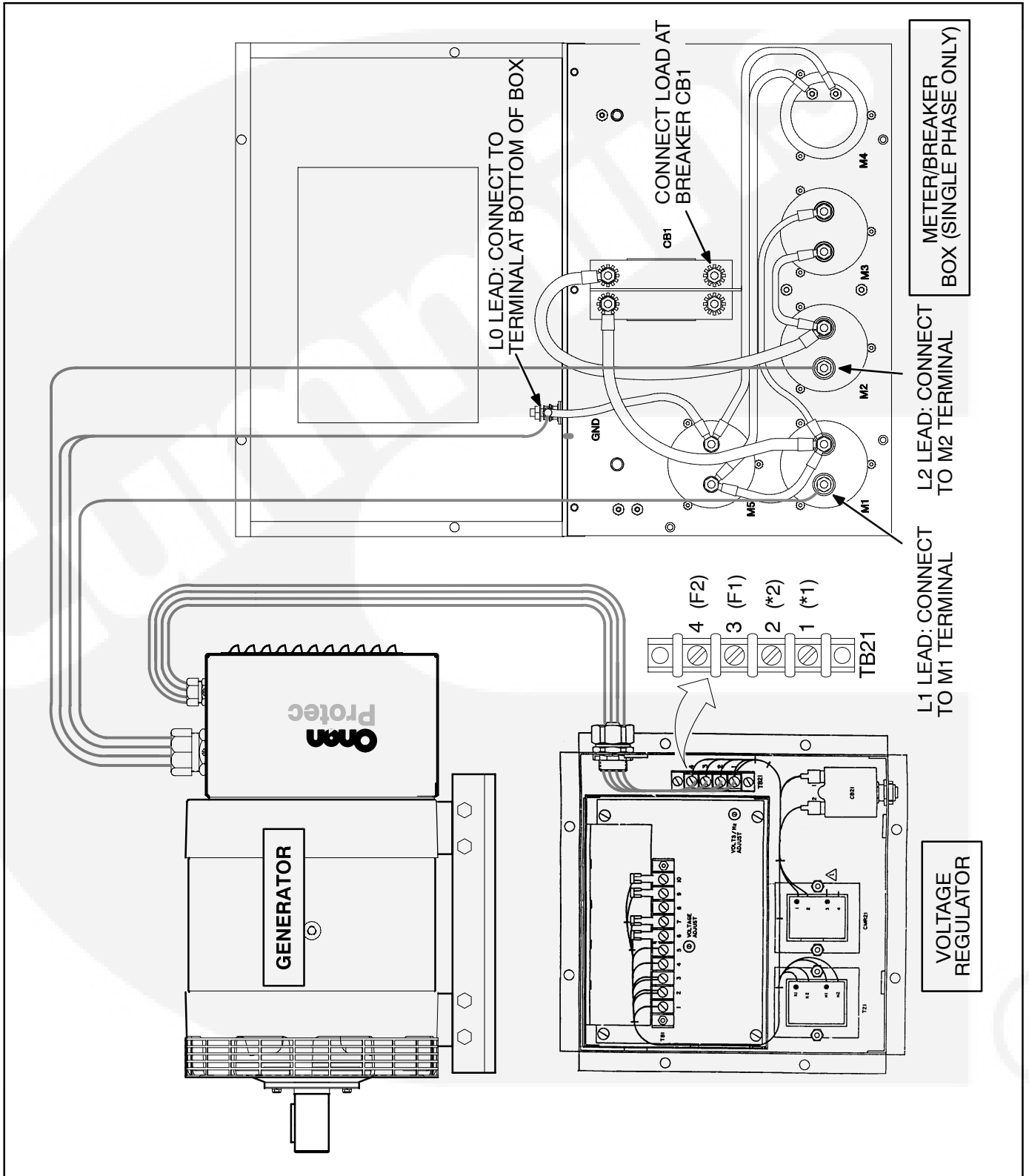

FIGURE 6-1. 15 KW GENERATOR WIRING



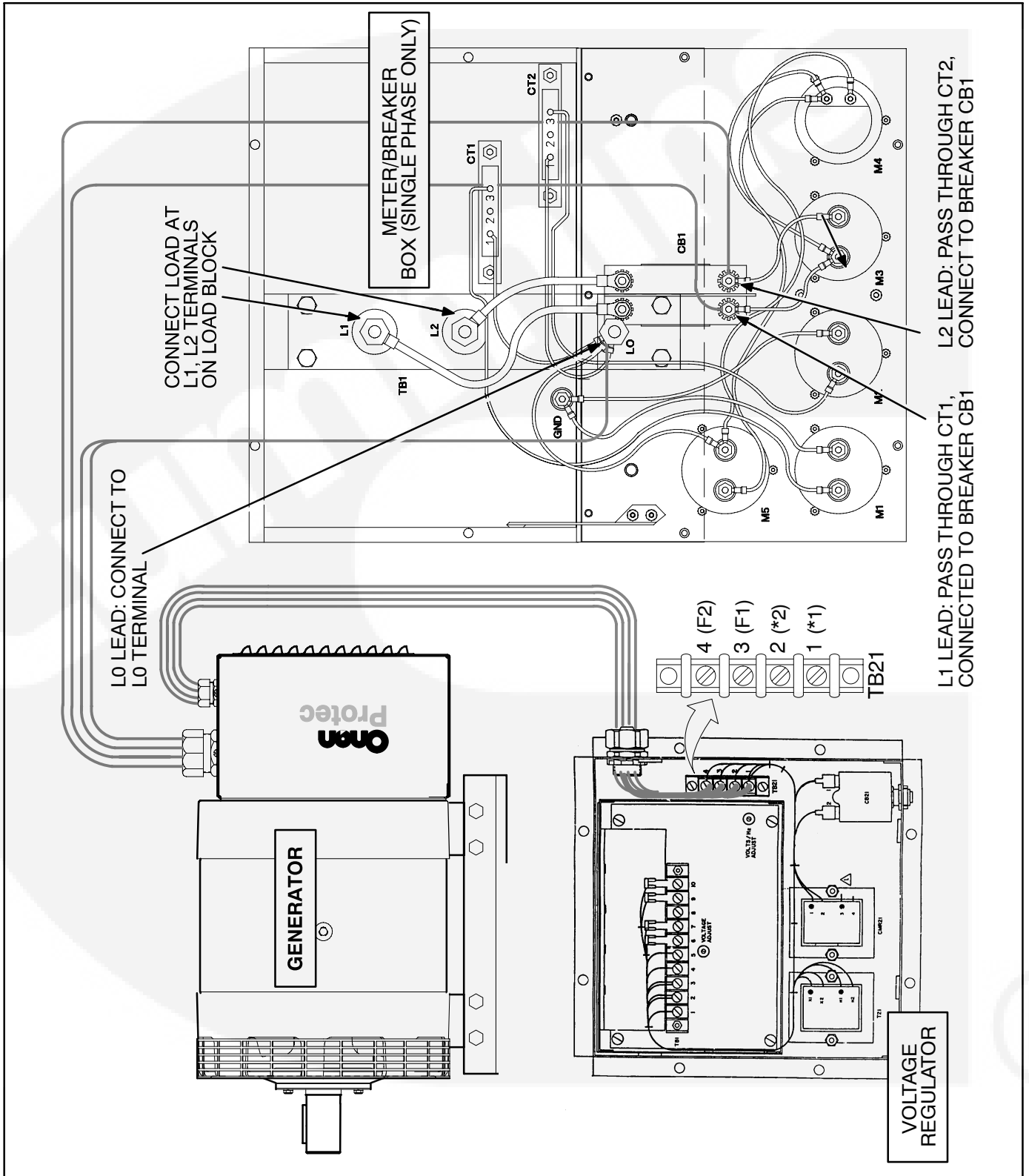

FIGURE 6-2. 20.24 KW GENERATOR WIRING

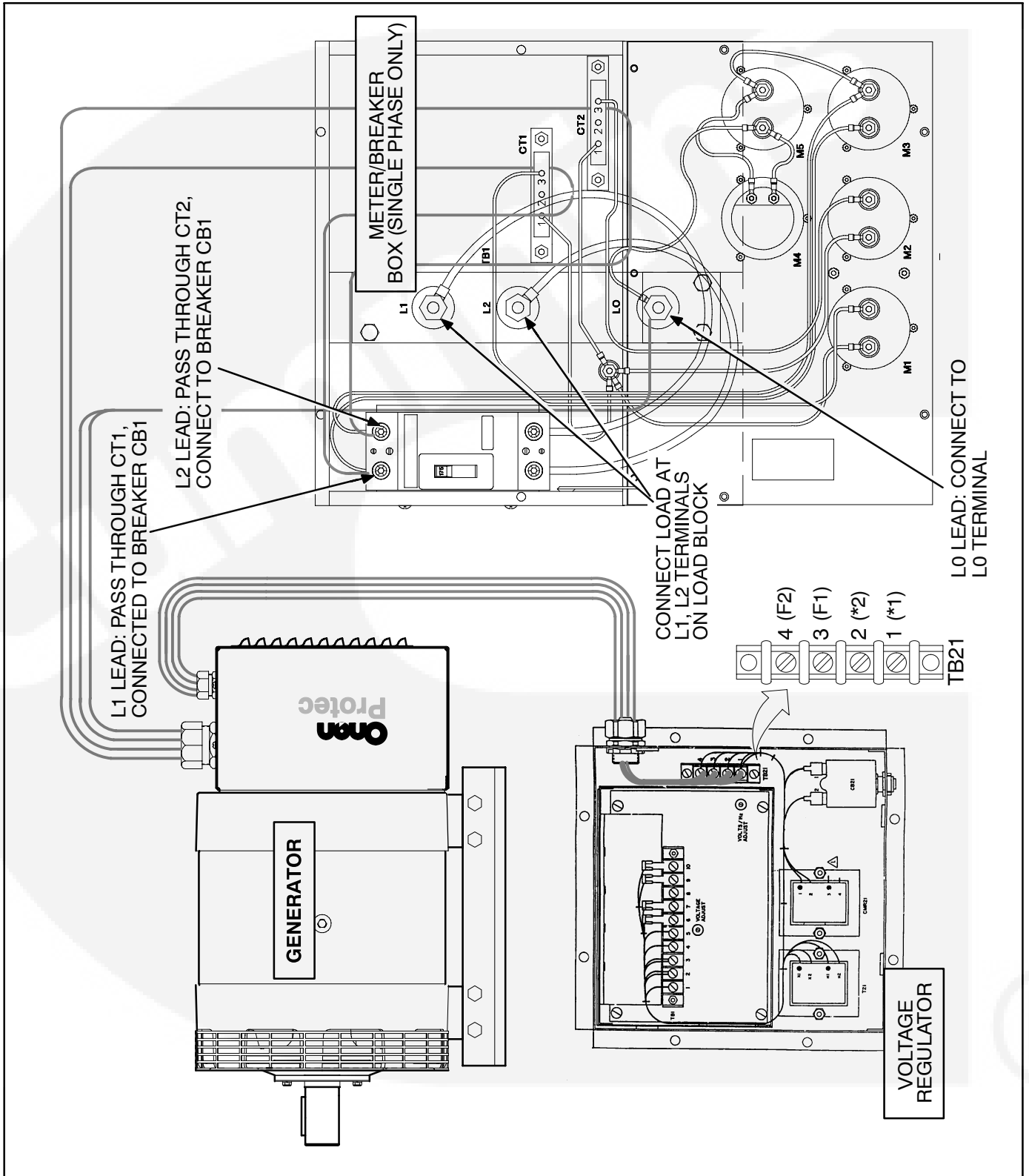

FIGURE 6-3. 30, 35 KW GENERATOR WIRING

---

## OUTPUT VOLTAGE FREQUENCY CONVERSION

**⚠WARNING** *Electrical shock can cause severe personal injury or death. Use extreme caution when working on electrical circuitry. Attach and remove jumpers only when generator is not operating.*

Note that the Onan meter/breaker box for 50 Hz applications is a different component than the meter/breaker box for 60 Hz applications. The two components are not interchangeable: the correct meter/breaker box must be installed for the application.

The frequency of the voltage output from the YD PTO generator may be converted from 60 Hz to 50 Hz, or from 50 Hz to 60 Hz, by performing the following steps (see Figure 6-4):

1. Stop the generator. Disable the propulsion engine and PTO unit. Remove the propulsion engine battery leads, negative (-) lead first, so that there is no possibility of the engine being started.
2. Remove the cover to the voltage regulator box.
3. Locate terminal block TB1 inside the voltage regulator box.
- 4a. **60 Hz to 50 Hz conversion:** Retain the jumper between terminals 6 and 7. Install an additional

jumper between terminals 7 and 8. Readjust the speed of the generator/PTO from 1800 RPM to 1500 RPM.

- 4b. **50 Hz to 60 Hz conversion:** Remove the jumper between terminals 7 and 8. Readjust the speed of the generator/PTO from 1500 RPM to 1800 RPM.

**⚠WARNING** *Failure to operate the YD PTO generator at the correct speed may damage or destroy the generator and associated equipment. All governors or speed-regulating systems must be in place, working correctly and activated before the YD PTO generator can be used.*

5. Start the engine/governor/PTO/generator system, recheck output voltage and adjust as necessary using the voltage adjustment on the voltage regulator (see Figure 6-4).

**⚠WARNING** *Electrical shock can cause severe personal injury or death. Attach and remove meter leads only when generator is not operating. Do not touch meter or meter leads during testing. Use extreme caution when adjusting output voltage: exposed terminals inside voltage regulator box carry full generator output voltage potential.*



**60 HZ TO 50 HZ CONVERSION:** RETAIN THE JUMPER BETWEEN TERMINALS 6 AND 7. INSTALL AN ADDITIONAL JUMPER BETWEEN TERMINALS 7 AND 8. READJUST THE SPEED OF THE GENERATOR / PTO FROM 1800 RPM TO 1500 RPM.

**50 HZ TO 60 HZ CONVERSION:** REMOVE JUMPER BETWEEN TERMINALS 7 AND 8. OPERATE GENERATOR AT 1800 RPM, READJUST VOLTAGE

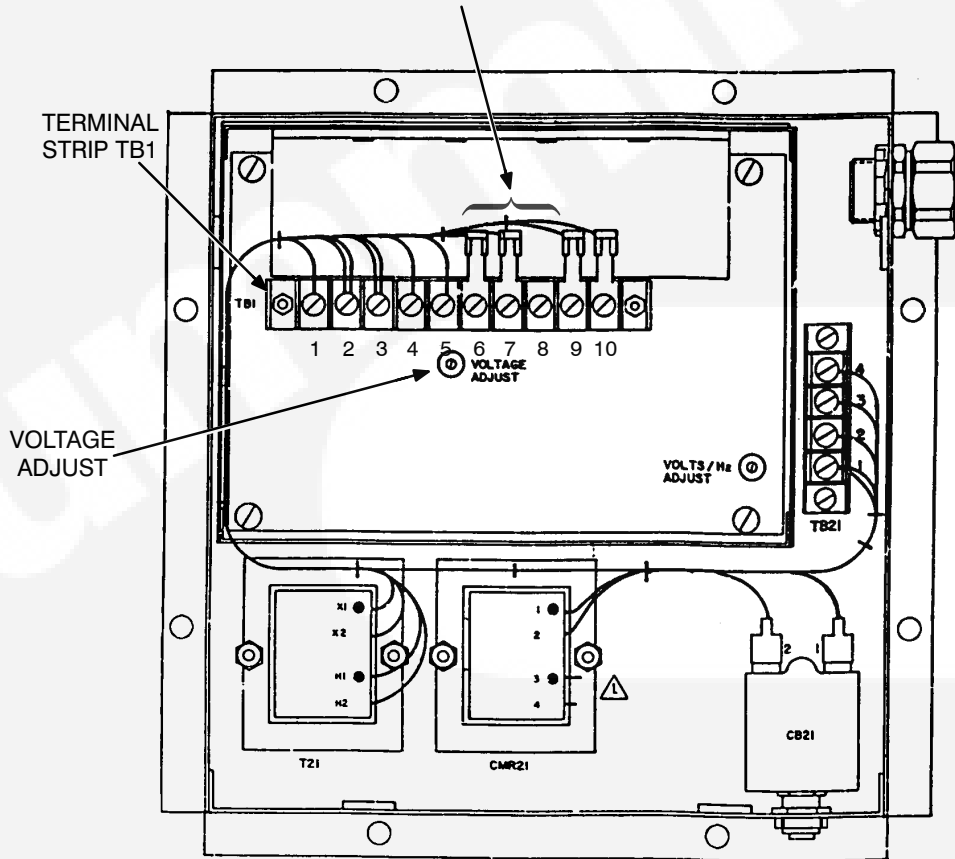

VOLTAGE REGULATOR BOX  
SHOWN WITH COVER REMOVED

FIGURE 6-4. GENERATOR OUTPUT VOLTAGE FREQUENCY CONVERSION (50 OR 60 HZ)



THIS PAGE INTENTIONALLY LEFT BLANK



# Section 7. Installation and Wiring Diagrams

---

<b>DRAWING</b>	<b>PAGE</b>
15 KW Generator Meter/Breaker Panel Schematic Diagram .....	7-2
20/25 KW Generator Meter/Breaker Panel Schematic Diagram .....	7-3
30/35 KW Generator Meter/Breaker Panel Schematic Diagram .....	7-4
Voltage Regulator Box Dimensions .....	7-5
Meter/Breaker Panel Dimensions, Mounting Holes, Conduit Openings (all models) .....	7-6
YD PTO AC Generator Dimensional Drawing .....	7-7
YD PTO AC Generator Wiring Diagram (Single Phase) .....	7-8
YD PTO AC Generator Wiring Diagram (Three Phase) .....	7-9

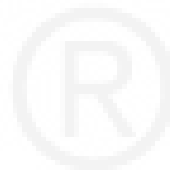

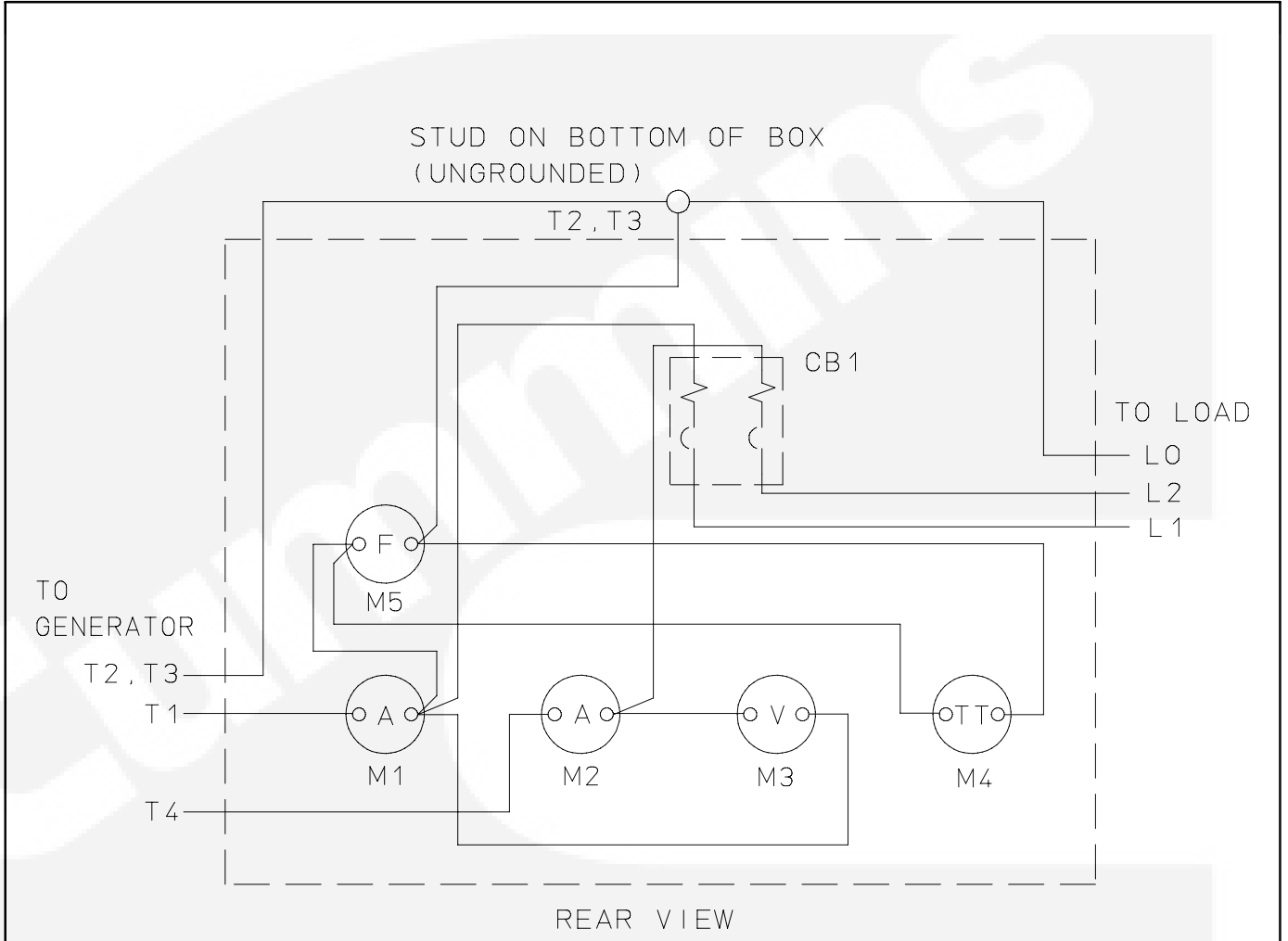

CIRCUIT BREAKER	CB 1
METER-FREQUENCY	M5
METER-TOTAL TIME	M4
METER-AC VOLT	M3
METER-AC AMMETER	M1, 2
ASSY-SWITCHBOARD	
DESCRIPTION OR MATERIAL	REF DES

**15 KW GENERATOR METER/BREAKER PANEL SCHEMATIC DIAGRAM**

**NO. 615-0426  
REV. A  
MODIFIED 5/10/94**

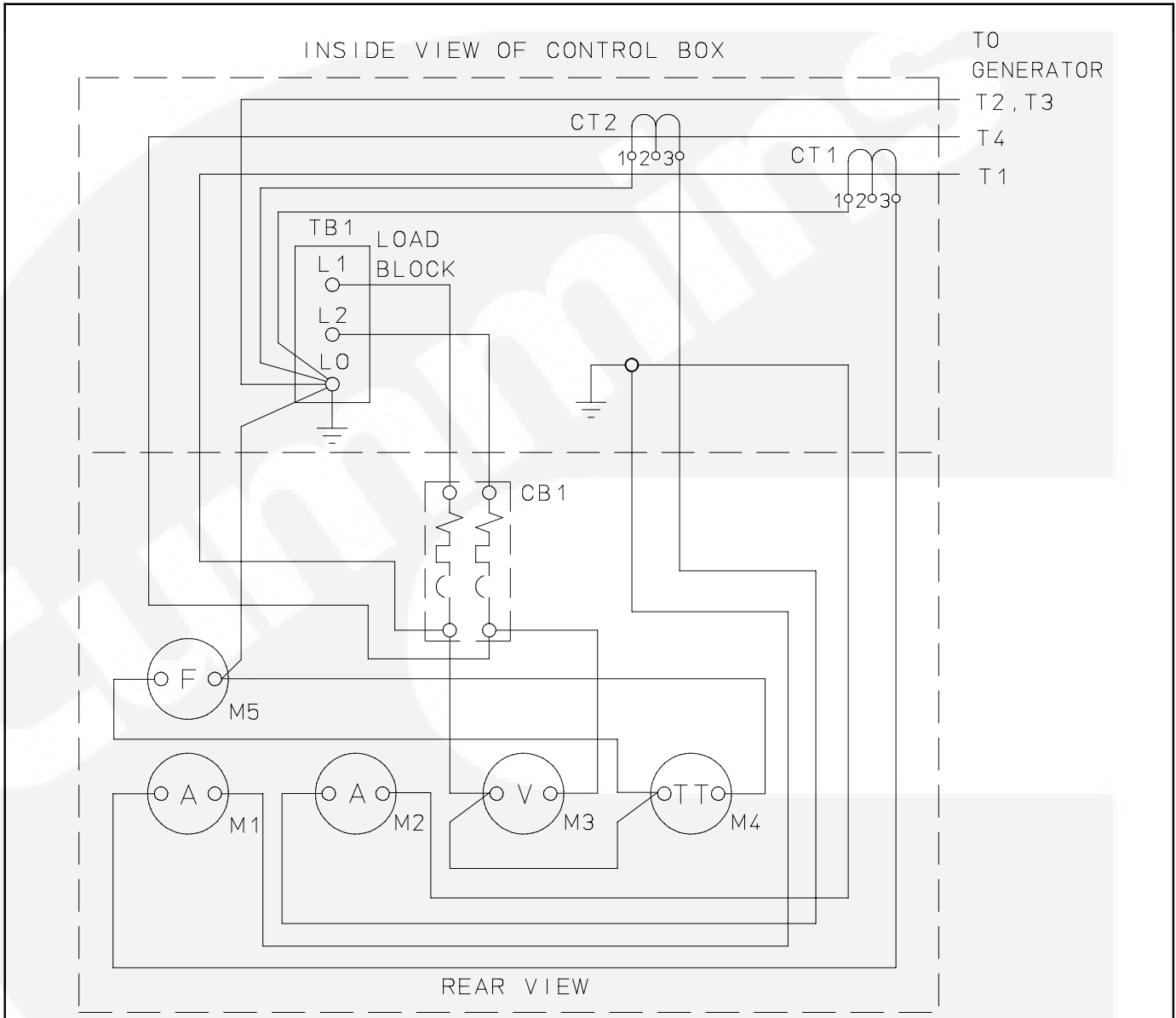

TERMINAL BLOCK	TB1
CIRCUIT BREAKER	CB1
TRANSFORMER-CURRENT	CT1, CT2
METER-FREQUENCY	M5
METER-TIME TOTALIZING	M4
METER-AC VOLTAGE	M3
METER-AC AMMETER	M1, 2
DESCRIPTION OR MATERIAL	REF DES

**20, 25 KW GENERATOR METER/BREAKER PANEL SCHEMATIC DIAGRAM**

**NO. 615-0427  
REV. B  
MODIFIED 8/18/94**



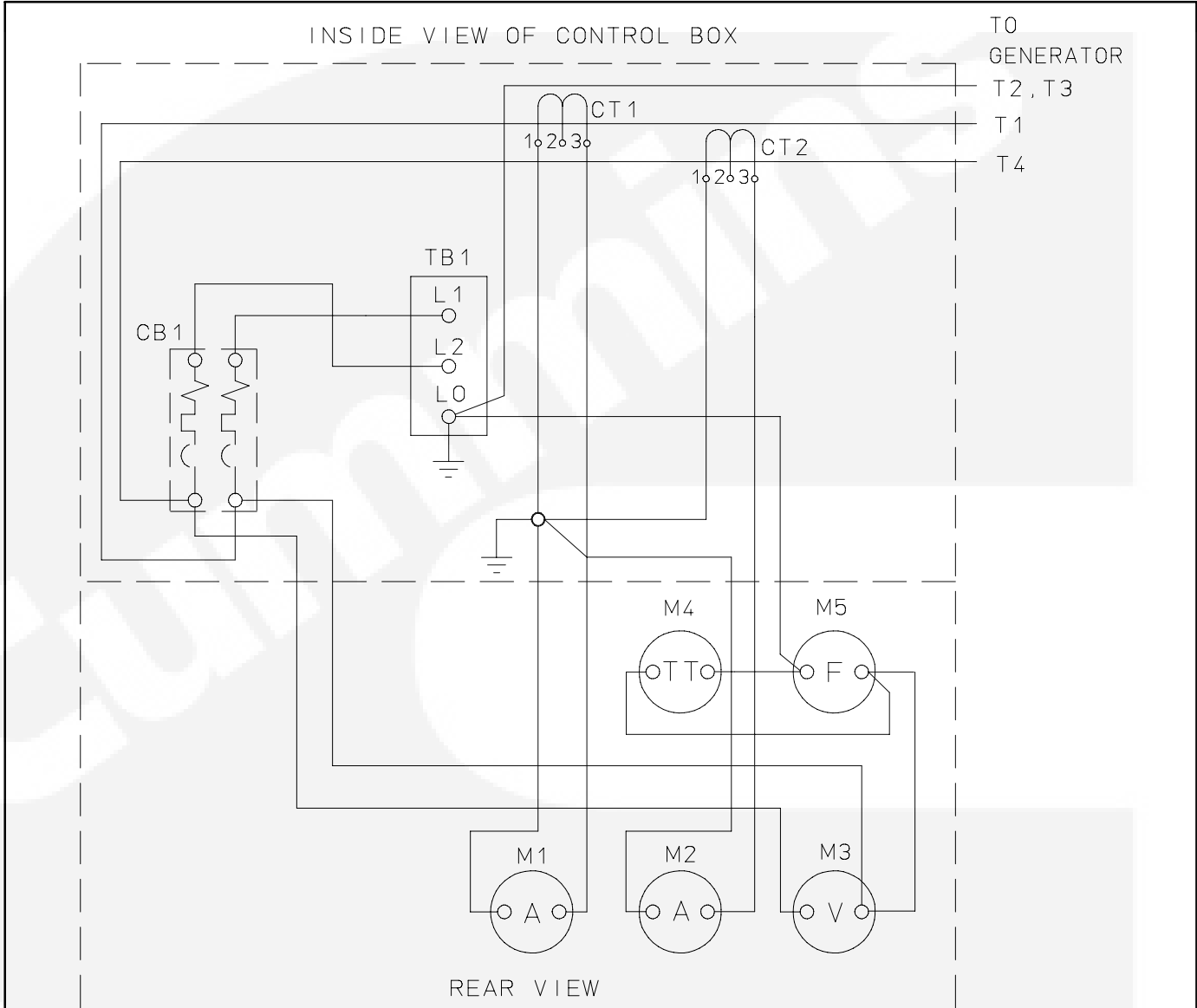

TERMINAL BLOCK	TB1
CIRCUIT BREAKER	CB1
TRANSFORMER-CURRENT	CT1, CT2
METER-FREQUENCY	M5
METER-TIME TOTALIZING	M4
METER-AC VOLTAGE	M3
METER-AC AMMETER	M1, 2
DESCRIPTION OR MATERIAL	REF DES

**30, 35 KW GENERATOR METER/BREAKER PANEL SCHEMATIC DIAGRAM**

**NO. 615-0428  
REV. A  
MODIFIED 7/28/94**

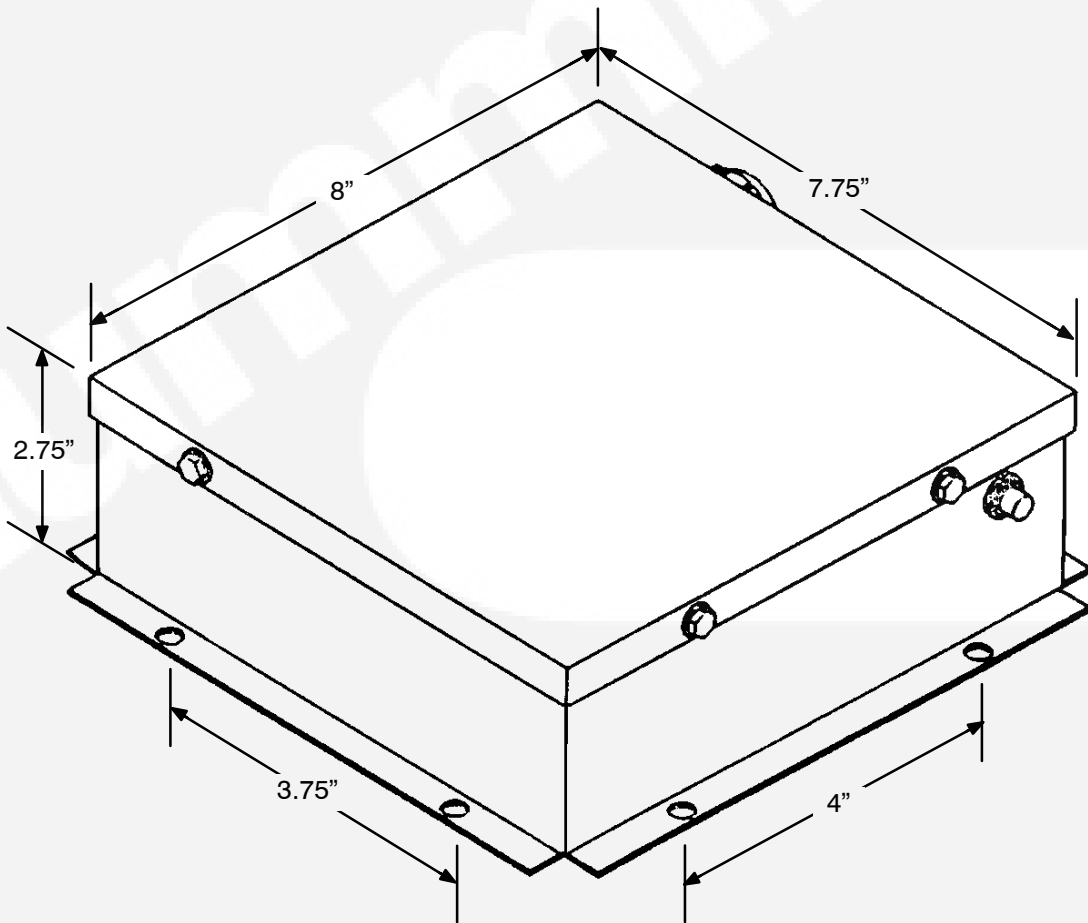

VOLTAGE REGULATOR BOX DIMENSIONS

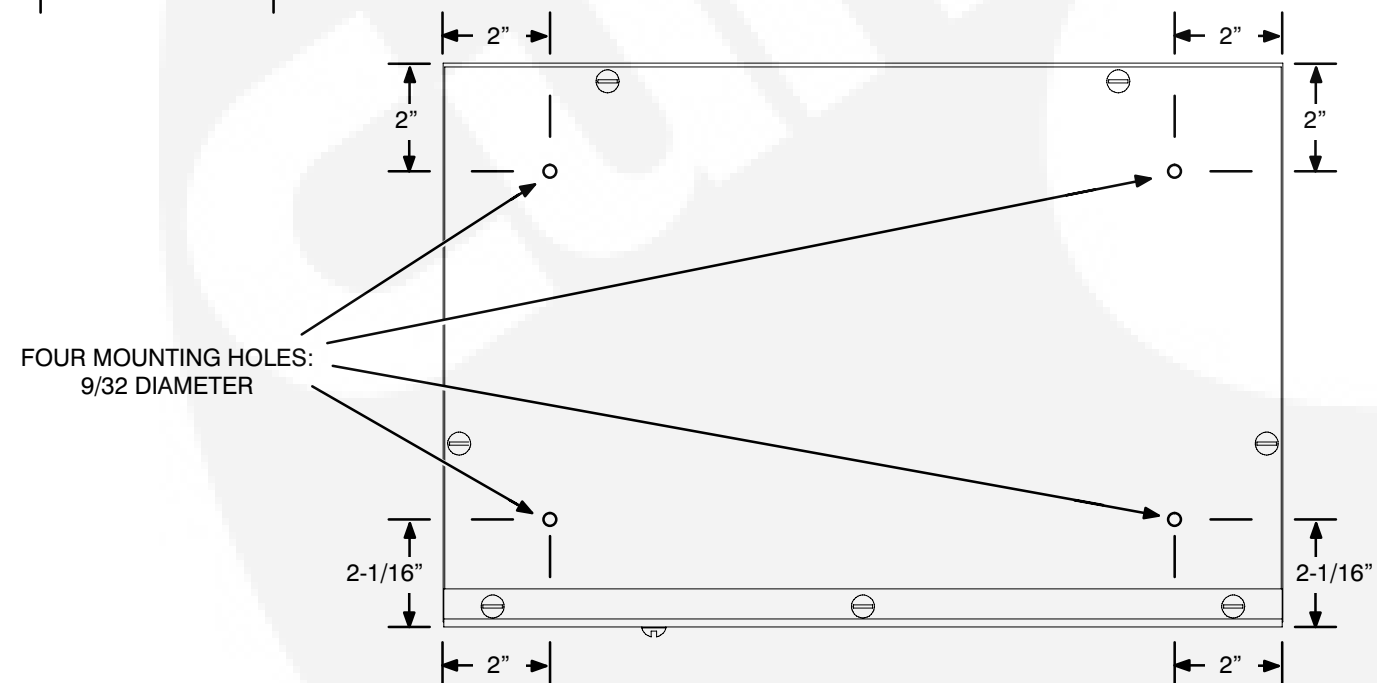
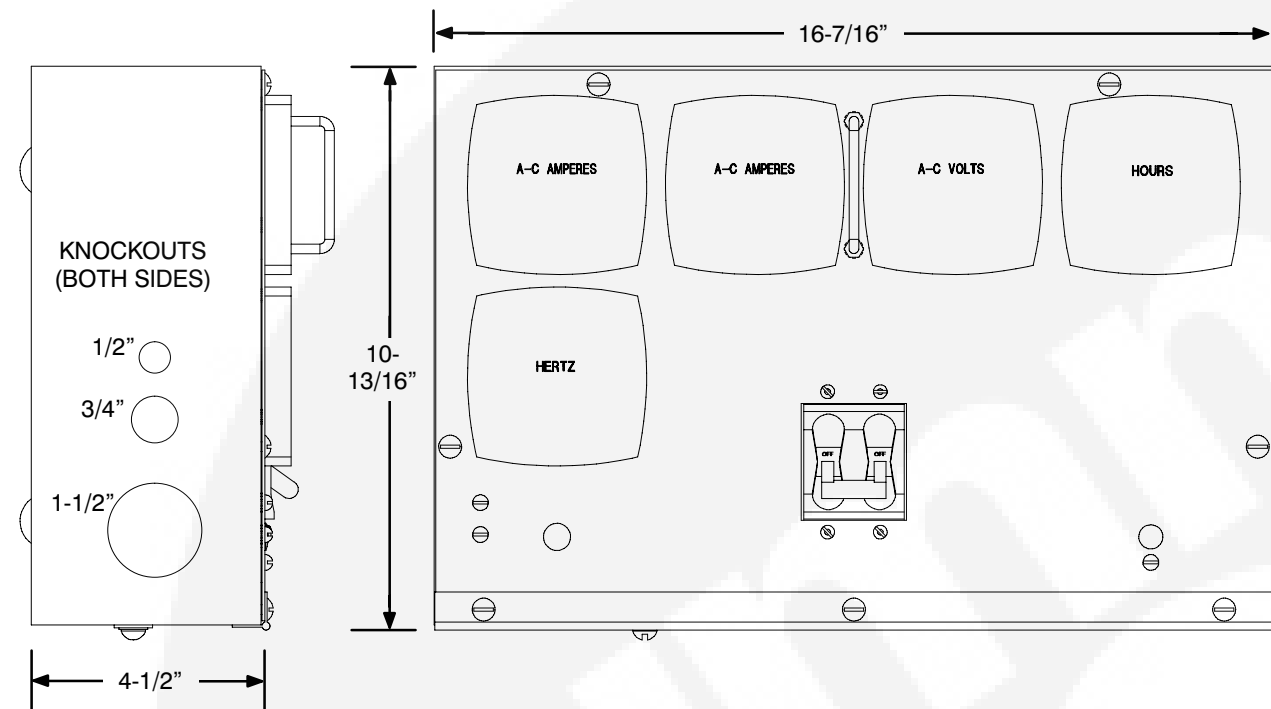

**15 KW YD PTO GENERATOR METER/BREAKER PANEL  
DIMENSIONS, MOUNTING HOLES, AND CONDUIT OPENINGS**

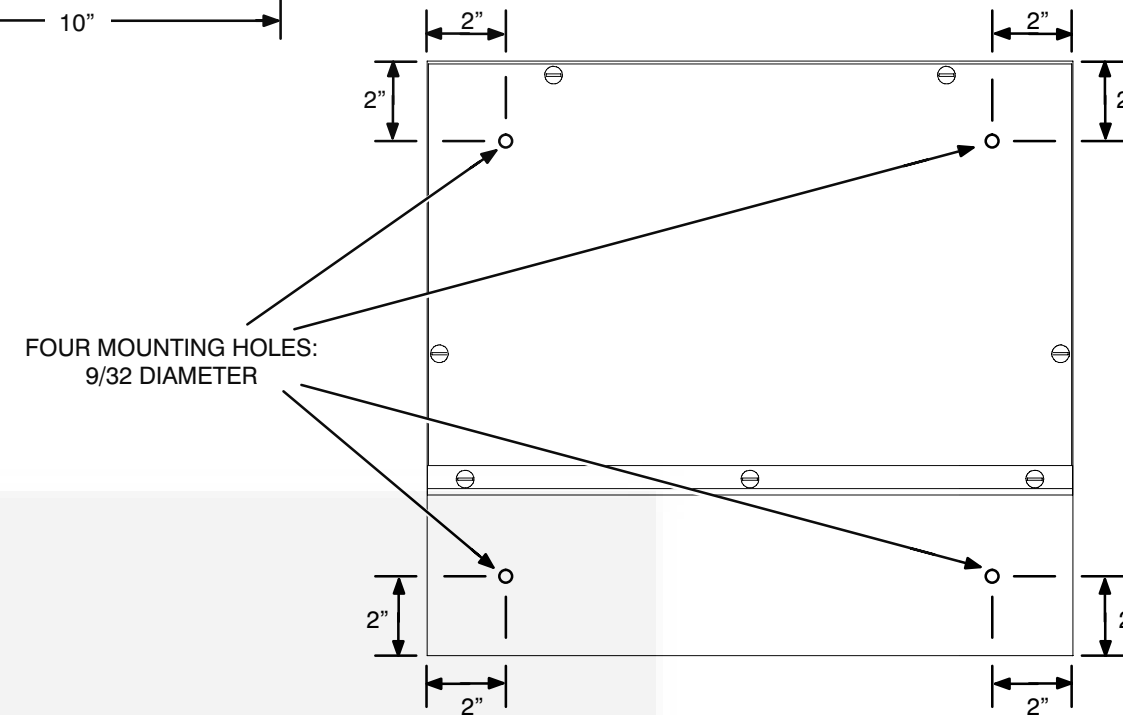
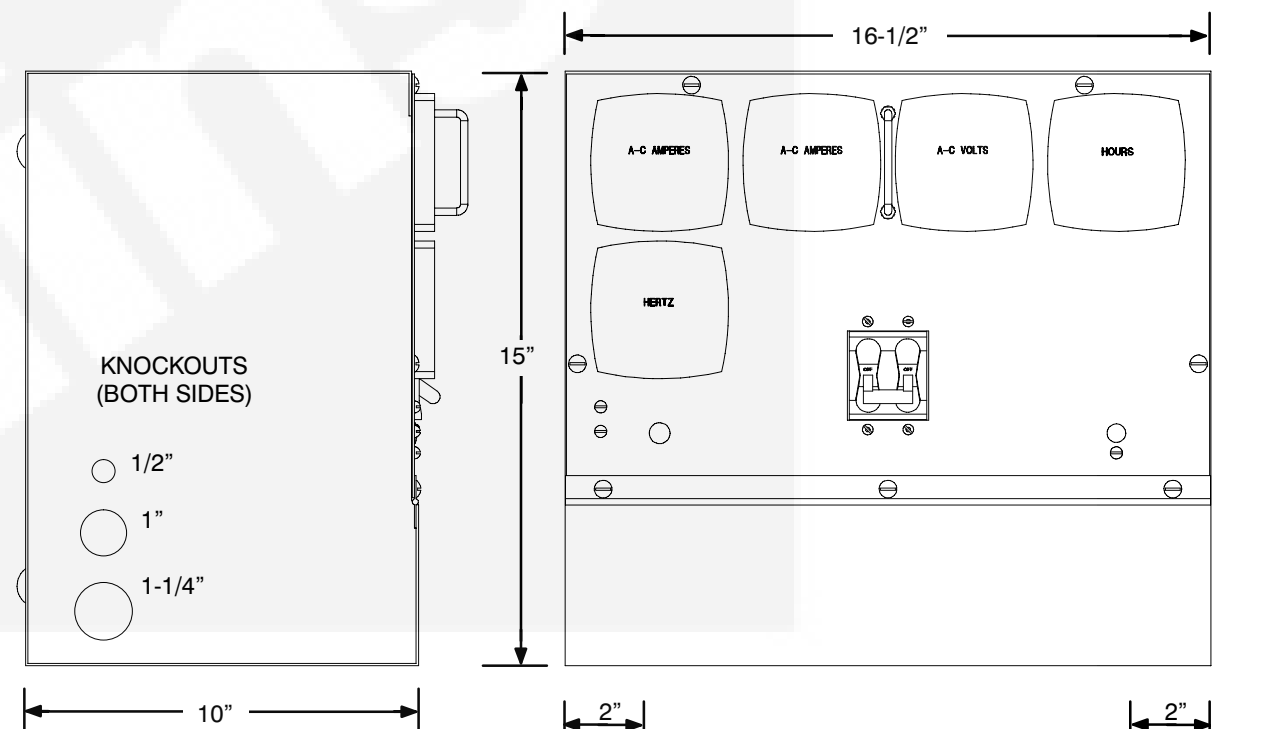

**20 THROUGH 35 KW YD PTO GENERATOR METER/BREAKER PANEL  
DIMENSIONS, MOUNTING HOLES, AND CONDUIT OPENINGS**



TABULATION					
OUTLINE-GEN	FRAME DESIGNATION CODE	CURRENT ER NO.	DIM A	DIM B	APPROX WEIGHT (LBS)
0500-3142-01	0431	50438	25.68	17.44	301
0500-3142-02	0575	50438	27.12	17.44	351
0500-3142-03	0700	50438	28.37	17.44	393
0500-3142-04	0862	50438	30.00	22.19	448
0500-3142-05	1038	50438	31.75	22.19	507

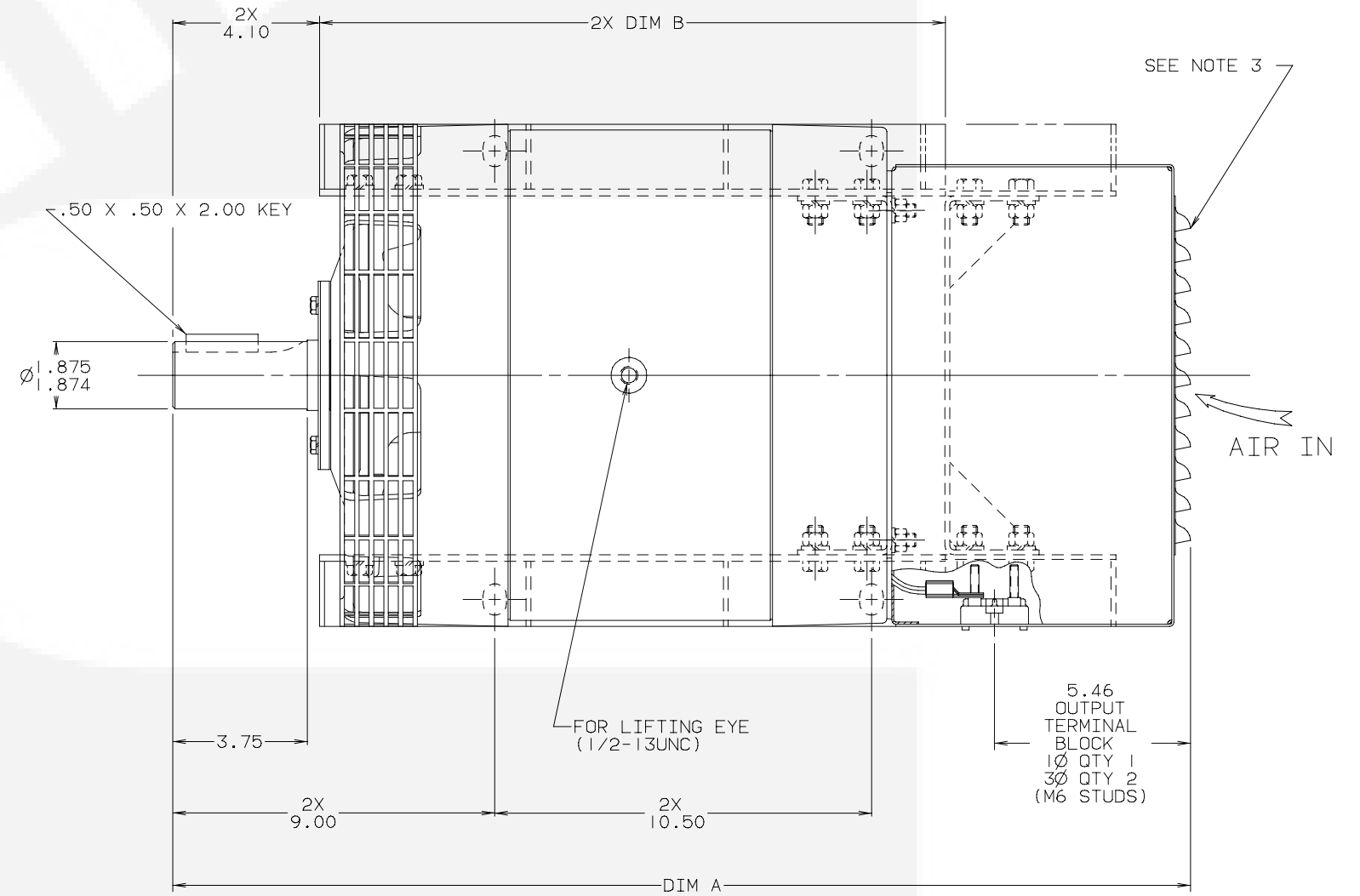
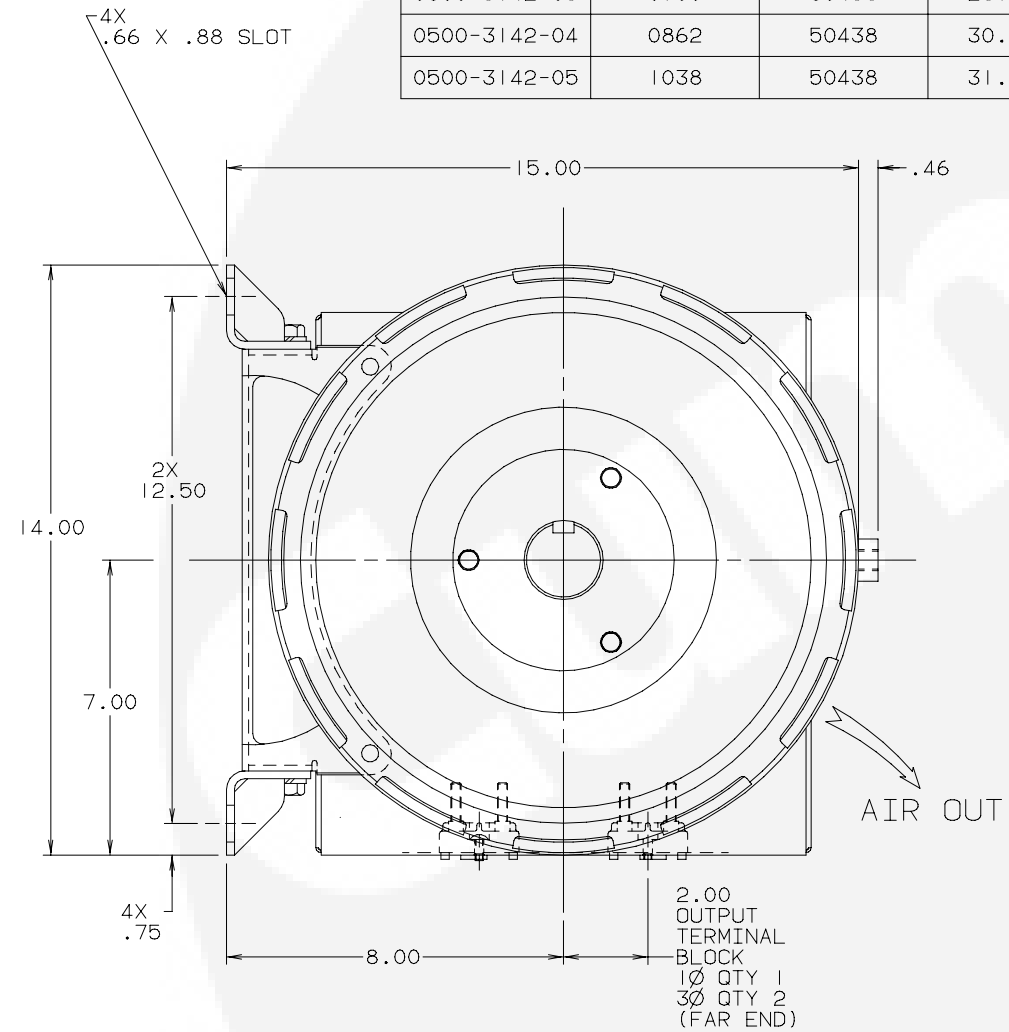

NOTES:

1. NEMA FRAME DESIGNATION-324TS
2. SHAFT SPEED:  
1800 RPM, 60HZ  
1500 RPM, 50HZ
3. RE-POSITION OUTPUT BOX COVER (LOUVERS)  
TO MATCH PEDESTAL MOUNT CONFIGURATION.  
SIDE MOUNT SHOWN.

YD PTO AC GENERATOR DIMENSIONAL DRAWING

No.500-3142 Sh 1 of 1  
Rev. A Sys: CADAM  
Modified 8/7/96



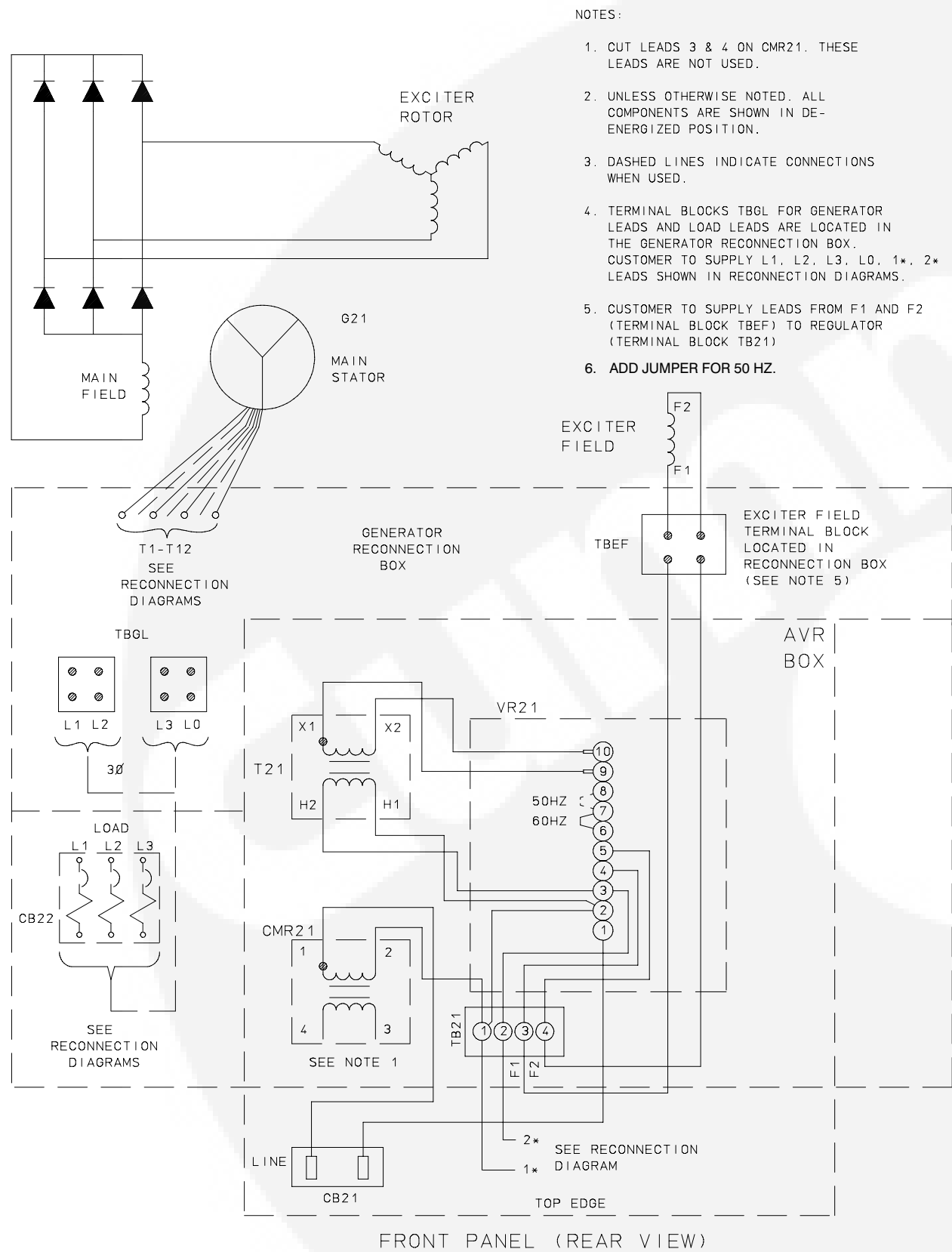

- NOTES:
1. CUT LEADS 3 & 4 ON CMR21. THESE LEADS ARE NOT USED.
  2. UNLESS OTHERWISE NOTED, ALL COMPONENTS ARE SHOWN IN DE-ENERGIZED POSITION.
  3. DASHED LINES INDICATE CONNECTIONS WHEN USED.
  4. TERMINAL BLOCKS TBGL FOR GENERATOR LEADS AND LOAD LEADS ARE LOCATED IN THE GENERATOR RECONNECTION BOX. CUSTOMER TO SUPPLY L1, L2, L3, L0, 1\*, 2\* LEADS SHOWN IN RECONNECTION DIAGRAMS.
  5. CUSTOMER TO SUPPLY LEADS FROM F1 AND F2 (TERMINAL BLOCK TBEF) TO REGULATOR (TERMINAL BLOCK TB21)
  6. ADD JUMPER FOR 50 HZ.

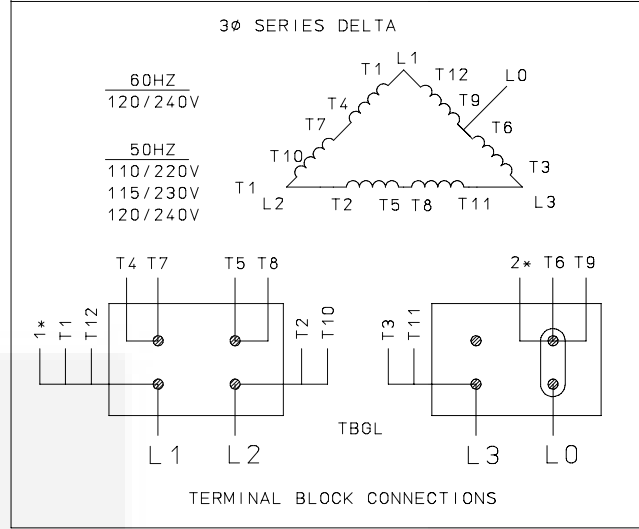
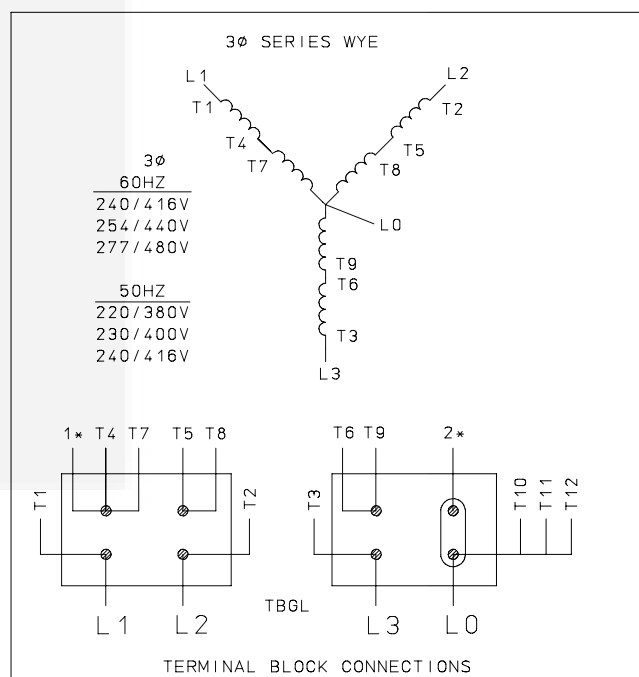
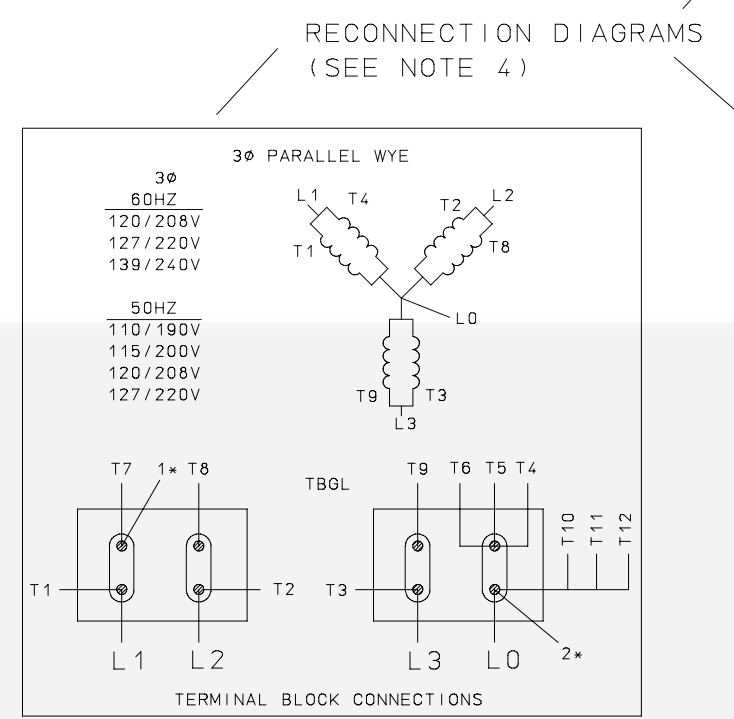
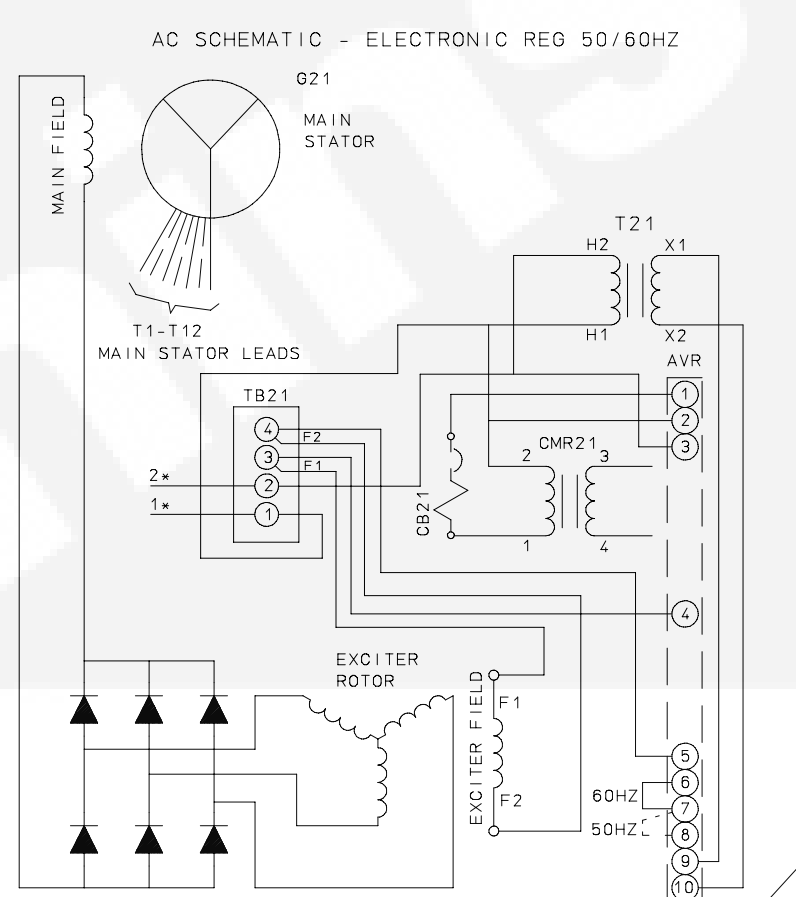

TBGL	TERMINAL BLOCK GEN AND LOAD LEADS
TBEF	TERMINAL BLOCK EXCITER FIELD
T21	TRANSFORMER-VOLT REF
CMR21	REACTOR ASSEMBLY-LOAD
G21	GENERATOR (AC)
CB22	CIRCUIT BREAKER-LOAD
CB21	CIRCUIT BREAKER-MAG 3A
VR21	REGULATOR-ASSEMBLY VOLT

WIRING DIAGRAM, YD PTO AC GENERATOR (THREE PHASE)

No. 612-6716 Sh 1 of 1  
Rev. C Sys: HP  
Modified 4/18/97

Cummins

THIS PAGE INTENTIONALLY LEFT BLANK





**Onan**

Cummins Power Generation  
1400 73rd Avenue N.E.  
Minneapolis, MN 55432  
763-574-5000  
Fax: 763-574-8087

Cummins and Onan are registered trademarks of Cummins Inc.