



Service Manual

Onan Generator Set for RV

HGJAA (Spec A-E)

HGJAB (Spec A-E)

HGJAC (Spec A-C)

HGJAD (Spec A-E)

HGJAE (Spec A-E)

HGJAF (Spec A-C)

Table of Contents

1. SAFETY PRECAUTIONS	1
1.1 General Precautions	1
1.2 Generator Set Voltage Is Deadly	1
1.3 Engine Exhaust Is Deadly	2
1.4 Fuel is Flammable and Explosive	2
1.5 Battery Gas Is Explosive	2
1.6 Moving Parts Can Cause Severe Personal Injury or Death	2
2. ABOUT THIS MANUAL	3
3. OPERATION	5
3.1 Fuel Recommendations	5
3.2 Gasoline Models	5
3.3 LPG Models	5
3.4 Engine Oil Recommendations	5
3.5 Starting Batteries	6
3.6 Generator Set Control Panel	6
3.7 Remote Control Panel	6
3.8 Conducting Pre-Start Checks	8
3.9 Priming Gasoline Fuel Systems	9
3.10 Starting the Generator Set	9
3.11 Stopping the Generator Set	9
3.12 Restarting the Generator Set	9
3.13 Engine Run Only Operation	10
3.14 Generator Set Lockout Switch (HGJAD and HGJAE Models Only)	10
4. PERIODIC MAINTENANCE SCHEDULE	11
4.1 Conducting General Inspections	12
4.1.1 Oil Level	12
4.1.2 Exhaust System	12
4.1.3 Fuel System	12
4.1.4 Battery Connections	13
4.1.5 Mechanical	13
4.2 Checking Engine Oil Level	13
4.3 Changing Engine Oil and Oil Filter	14
4.4 Maintaining the Battery and Battery Connections	16
4.5 Replacing the Air Filter Element	16
4.6 Replacing Spark Plugs	17
4.7 Cleaning the Spark Arrestor	18
4.8 Cleaning Cylinder Heads	19
5. PREPARING FOR SERVICE	21
5.1 Troubleshooting	21

5.2 Safety	21
5.3 Special Tools	22
5.3.1 Engine Tools	22
5.3.2 Alternator Tools	22
5.4 Removing the Generator Set Overview	23
5.4.1 Disconnecting the Generator Set	23
5.4.2 Removing the Generator Set	24
5.5 Installing the Generator Set	25
6. CONTROL	27
6.1 Controller A1	27
6.1.1 Major Functions of Controller A1	27
6.1.2 Controller A1 Removal/Replacement	29
6.2 Other Control Components	29
6.2.1 Control Switch S1	29
6.2.2 Line Circuit Breakers CB1	30
6.2.3 Hour Meter	30
6.2.4 3-Phase Voltage Sense Transformer	31
6.2.5 Battery Charge Regulator	31
6.2.6 Alternator DC Grounds	32
6.2.7 Alternator Neutral Ground Screw	32
6.2.8 Bond Strap	32
6.2.9 Remote Control Connector P2/J2	32
6.2.10 Fuel Pump Connector	33
6.2.11 Batteries	34
6.2.12 Battery Cables	34
6.2.13 Battery Cable Connections at Generator Set	36
6.2.14 Generator Set (Equipment) Grounding Screw	36
7. GENERATOR	39
7.1 Alternator Description	39
7.1.1 Stator	40
7.1.2 Rotor	41
7.1.3 Generator Set Cooling Fan	41
7.1.4 Brush Block	41
7.1.5 Voltage Regulator	41
7.1.6 Line Circuit Breakers	41
7.1.7 Principle of Operation	41
7.2 Alternator Service	41
7.2.1 Stator Removal	41
7.2.2 Stator Reassembly	42
7.2.3 Rotor Removal	42
7.2.4 Rotor Reassembly	42
7.3 Brushes and Slip Rings	42
7.3.1 Brush Block	42
7.3.2 Slip Rings	43
7.4 Alternator Testing	43

7.4.1 Rotor Tests.....	43
7.4.2 Stator Tests.....	44
7.5 Voltage Adjustments	45
7.6 Alternator Connections	45
8. FAN, DRIVE BELT, FLYWHEEL, IGNITION, AND EXHAUST	49
8.1 Fan, Belt, Pulleys and Flywheel.....	49
8.1.1 Removing Fan and Alternator Pulley	49
8.1.2 Removing Flywheel and Engine Pulley	50
8.1.3 Removing Tensioner Pulley	50
8.1.4 Reassembling Pulleys and Flywheel	50
8.2 Ignition System	52
8.2.1 Spark Plugs.....	52
8.2.2 Spark Check.....	53
8.2.3 Ignition Coil (Magnetos) Service	53
8.3 Exhaust System	55
8.3.1 Exhaust Manifold Removal	56
8.3.2 Exhaust Manifold Installation	56
8.3.3 HGJAA, HGJAB, HGJAD, and HGJAE Model Mufflers	57
8.3.4 HGJAC, HGJAF Mufflers	58
8.3.5 Exhaust Tail Pipe Installation.....	60
9. FUEL SYSTEM	63
9.1 Gasoline Fuel System—HGJAA and HGJAD	63
9.1.1 Operation	63
9.1.2 Throttle Body Removal	64
9.1.3 Intake Manifold Removal	64
9.1.4 Reassembly	64
9.1.5 Fuel Rail and Injectors	65
9.1.6 Fuel Pressure Regulator	66
9.1.7 MAT Sensor	67
9.1.8 MAP Sensor	68
9.1.9 Throttle Body/Governor Actuator	70
9.1.10 Remote Fuel Pump	72
9.1.11 Fuel Connections	74
9.2 Gasoline Fuel System—HGJAB and HGJAE	75
9.2.1 Operation	76
9.2.2 Removing Carburetor.....	76
9.2.3 Removing Intake Manifold	76
9.2.4 Reassembly	76
9.2.5 Carburetor	77
9.2.6 Automatic Choke.....	77
9.2.7 Fuel Cutoff Solenoid E4	78
9.2.8 Fuel Filters	79
9.2.9 Fuel Pump.....	79
9.2.10 Fuel Connections	79
9.3 LPG Fuel System—HGJAB and HGJAE	81

9.3.1 Operation	81
9.3.2 Mixer Removal	81
9.3.3 Intake Manifold Removal	82
9.3.4 Reassembly	82
9.3.5 Low-Pressure LPG Demand Regulator	83
9.3.6 Testing Low-Pressure LPG Shutoff E4	84
9.3.7 Low-Pressure LPG Filter Cleaning	85
9.3.8 Low-Pressure LPG Supply Connections.....	85
9.3.9 High-Pressure LPG Converter (Regulator).....	86
9.3.10 Testing High-Pressure LPG Shutoff E4	86
9.3.11 High-Pressure LPG Filter Cleaning	87
9.3.12 High-Pressure LPG Supply Connections.....	87
9.4 Mechanical Governor—HGJAB and HGJAE	89
9.4.1 Assembling Governor Linkage	90
9.4.2 Resetting Governor Arm	90
9.4.3 Adjusting Governor	90
10. ENGINE	93
10.1 Testing Compression/Leakdown.....	93
10.2 Testing Crankcase Vacuum.....	93
10.3 Removing and Installing Alternator/Engine Assembly	93
10.3.1 Removal	93
10.3.2 Installation	94
10.4 Removing and Installing Engine	96
10.4.1 Removal	96
10.4.2 Installation	96
10.5 Starter Motor	96
10.5.1 Starter Motor Replacement.....	96
10.5.2 Starter Motor Solenoid Replacement.....	96
10.6 Valve Lash Adjustment	97
10.7 Cylinder Heads and Valves	98
10.7.1 Removal and Disassembly	98
10.7.2 Reassembly and Installation	99
10.7.3 Rocker Arms and Push Rods	100
10.7.4 Breather Valve	101
10.8 Crankcase Assembly	101
10.8.1 Disassembly	101
10.8.2 Assembly.....	101
10.8.3 Crankshaft.....	105
10.8.4 Piston Rings.....	105
10.8.5 Piston/Connecting Rod Assembly.....	106
10.8.6 Camshaft and Tappets.....	106
10.8.7 Crankshaft End Play	107
10.8.8 Crankshaft Oil Seal	108
10.8.9 Main Bearing Cover	109
10.8.10 Oil Pump Lubrication.....	109

10.8.11 Oil Control Leaf Valves	111
10.8.12 Mechanical Governor—HGJAB and HGJAE	112
10.9 Dimensions and Clearances	115
11. HYDRAULIC PUMP.....	121
11.1 Installing the Hydraulic Pump	121
11.2 Connecting Hydraulic Hoses.....	121
12. TROUBLESHOOTING OVERVIEW	123
12.1 Fault Codes.....	123
12.2 Generator Set Starts or Stops Without Command - No Fault Code.....	124
12.3 Generator Set Shuts Down With Fault Code - No Cause Determined.....	125
12.4 No Response - Status Indicator Light Dead	126
12.5 Starting Batteries Run Down	126
12.6 Starter Engages - Disengages.....	127
12.7 No AC Power - Generator Set Running Status LED on Steady or Flashing Rapidly	128
12.8 Generator Set Cranks But Does Not Start - No Fault Code.....	128
12.9 Generator Set Runs But Stops When Switch Is Released - No Fault Code	129
12.10 Engine Hard to Start - No Fault Code.....	129
12.11 Engine Runs Lean, Rough, or Surges - No Fault Code	130
12.12 Low Oil Pressure Fault - Fault Code 2	131
12.13 Service Check Fault - Fault Code 3.....	131
12.14 Overcrank - Fault Code 4	132
12.15 Overvoltage - Fault Code 12.....	134
12.16 Undervoltage - Fault Code 13.....	135
12.17 Overfrequency - Fault Code 14	136
12.18 Underfrequency - Fault Code 15	139
12.19 Fuel Pump Fault - Fault Code 17	141
12.20 Governor Actuator (EFI Only) - Fault Code 19	142
12.21 Governor Actuator Overload (EFI Only) - Fault Code 22	142
12.22 Oil Pressure Switch Fault - Fault Code 23	144
12.23 Voltage Sense Lost - Fault Code 27.....	144
12.24 High Battery Voltage - Fault Code 29.....	146
12.25 Overspeed Fault - Fault Code 31	147
12.26 Low Cranking Speed Sense - Fault Code 32	149
12.27 Fault Code 3 - Fault Code 33	151
12.28 Control Card Failure - Fault Code 35	152
12.29 Generator Set Stopped Without Fault Condition - Fault Code 36	152
12.30 Invalid Set Configuration - Fault Code 37.....	154
12.31 Field Overload (Overvoltage) - Fault Code 38.....	155
12.32 Alternator Rotor Fault - Fault Code 41	157
12.33 Processor Fault - Fault Code 42.....	159
12.34 Processor Fault - Fault Code 43.....	159
12.35 Speed Sense Fault - Fault Code 45	159
12.36 Ignition Fault - Fault Code 47	162
12.37 Field Sense Fault - Fault Code 48.....	163
12.38 Processor Failure - Fault Code 51.....	163

12.39 Fuel Injector Fault (EFI Only) - Fault Code 52	164
12.40 MAT Sensor Fault (EFI Only) - Fault Code 54	165
12.41 MAP Sensor Fault (EFI Only) - Fault Code 56	165
12.42 Overprime Fault - Fault Code 57	166
13. SERVICE CHECKLIST	169
13.1 General	169
13.2 Mounting	169
13.3 Wiring	169
13.4 Exhaust System	169
13.5 Fuel System	169
13.6 Startup	170
13.7 Output Check	171
13.8 Control	171
14. SPECIFICATIONS	173
14.1 Specifications	173
15. TORQUE SPECIFICATIONS	181
APPENDIX A. WIRING DIAGRAMS	183
A.0 Wiring Diagrams	185

1 Safety Precautions

Thoroughly read the operator manual before operating the generator set. Safe operation and top performance can be obtained only when equipment is operated and maintained properly.

The following symbols in this manual alert you to potential hazards to the operator, service person and equipment.

⚠ DANGER

Alerts you to an immediate hazard which will result in severe personal injury or death..

⚠ WARNING

Alerts you to a hazard or unsafe practice which can result in severe personal injury or death.

⚠ CAUTION

Alerts you to a hazard or unsafe practice which can result in personal injury or equipment damage.

When equipped with an integral or add-on Automatic Generator Starting System (AGS) control, exhaust carbon monoxide (CO), electric shock, and moving parts hazards are possible due to unexpected starting. Turn off AGS whenever performing maintenance or service, when the vehicle is stored between uses, is awaiting service, or is parked in a garage or other confined area.

1.1 General Precautions

- Keep ABC fire extinguishers handy.
- Make sure all fasteners are secure and torqued properly.
- Keep the generator set and its compartment clean. Excess oil and oily rags can catch fire. Do not store gear in the compartment it can restrict cooling air.
- Before working on the generator set, disconnect the negative (-) battery cable at the battery to prevent starting.
- Use caution when making adjustments while the generator set is running—hot, moving or electrically live parts can cause severe personal injury or death.
- Used engine oil has been identified by some state and federal agencies as causing cancer or reproductive toxicity. Do not ingest, inhale, or contact used oil or its vapors.
- Benzene and lead in some gasolines have been identified by some state and federal agencies as causing cancer or reproductive toxicity. Do not to ingest, inhale or contact gasoline or its vapors.
- Do not work on the generator set when mentally or physically fatigued or after consuming alcohol or drugs.
- Carefully follow all applicable local, state and federal codes.

1.2 Generator Set Voltage Is Deadly

- Disable the automatic generator set starting feature of an inverter-charger or other automatic starting device before servicing the generator set to avoid electric shock from unexpected starting.

-
- Generator set output connections must be made by a qualified electrician in accordance with applicable codes.
 - The generator set must not be connected to the public utility or any other source of electrical power. Connection could lead to electrocution of utility workers and damage to equipment. An approved switching device must be used to prevent interconnections.
 - Use caution when working on live electrical equipment. Remove jewelry, make sure clothing and shoes are dry and stand on a dry wooden platform.

1.3 Engine Exhaust Is Deadly

- Learn the symptoms of carbon monoxide poisoning in this manual and never occupy the vehicle while the generator set is running unless the vehicle is equipped with a working carbon monoxide detector.
- The exhaust system must be installed in accordance with the generator set installation manual. Engine cooling air must not be used for heating the working or living space or compartment.
- Inspect for exhaust leaks at every startup and after every eight hours of running.
- Make sure there is ample fresh air when operating the generator set in a confined area.

1.4 Fuel is Flammable and Explosive

- Do not smoke or turn electrical switches ON or OFF where fuel fumes are present or in areas sharing ventilation with fuel tanks or equipment. Keep flame, sparks, pilot lights, arc-producing equipment and switches and all other sources of ignition well away.
- Fuel lines must be secured, free of leaks and separated or shielded from electrical wiring.
- Leaks can lead to explosive accumulations of gas. LPG sinks when released and can accumulate inside housings and basements and other below-grade spaces. Prevent leaks and the accumulation of gas.

1.5 Battery Gas Is Explosive

- Wear safety glasses and do not smoke while servicing batteries.
- When disconnecting or reconnecting battery cables, always disconnect the negative (–) battery cable first and reconnect it last to reduce arcing.

1.6 Moving Parts Can Cause Severe Personal Injury or Death

- Disable the automatic generator set starting feature of an inverter-charger or other automatic starting device before servicing the generator set to avoid unexpected starting and injury.
- Do not wear loose clothing or jewelry near moving parts such as PTO shafts, fans, belts and pulleys.
- Keep hands away from moving parts.
- Keep guards in place over fans, belts, pulleys, etc.

2 About This Manual

This is the service manual for the generator set models listed on the front cover. Read and carefully observe all of the instructions and precautions in this manual.

⚠ WARNING

Improper service or replacement of parts can lead to severe personal injury or death and to damage to equipment and property. Service personnel must be trained and experienced to perform electrical and mechanical service.

⚠ WARNING

Unauthorized modifications or replacement of fuel, exhaust, air intake or speed control system components that affect engine emissions are prohibited by law in the State of California.

See the installation manual for important recommendations concerning the installation and for a list of the installation codes and standards for safety which may be applicable.

See the parts manual for part identification numbers and required quantities and for exploded views of the generator set subassemblies. Cummins replacement parts are recommended for best results.

When contacting Cummins for parts and product information, be ready to provide the model and serial numbers on the generator set nameplate. [Figure 1](#) illustrates the nameplate and its location. The numbers in the gray boxes are typical model and serial numbers. Every character in these numbers is significant. (The last character of the model number is the specification letter, which is important for obtaining the right parts.)

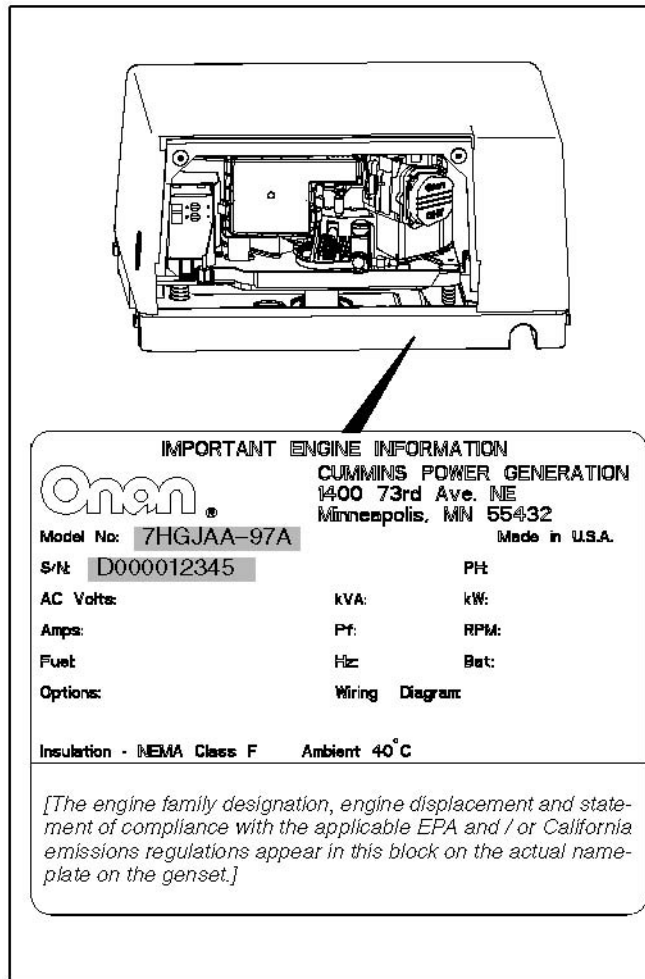

FIGURE 1. TYPICAL NAMEPLATE

3 Operation

3.1 Fuel Recommendations

⚠ WARNING

Gasoline and LPG are highly flammable and explosive and can cause severe personal injury or death. Do not smoke or turn electrical switches ON or OFF where fuel fumes, tanks or equipment are present or in areas sharing ventilation. Keep flames, sparks, pilot lights, arc-producing equipment and switches and all other sources of ignition well away. Keep a type ABC fire extinguisher in the vehicle.

3.2 Gasoline Models

Use clean, fresh unleaded gasoline having a minimum octane rating (Anti-Knock Index) of 87.

- Ethanol Blend - Not more than 10% ethanol.
- Methanol Blend - Not more than 5% methanol and the fuel must also contain solvents and corrosion inhibitors.

⚠ CAUTION

Do not use gasoline or gasoline additives containing methanol because methanol can be corrosive to fuel system components. Avoid using leaded gasoline because of the extra engine maintenance that will be required.

3.3 LPG Models

⚠ WARNING

High LPG supply pressure can cause gas leaks which can lead to fire and severe personal injury or death. LPG supply pressure on low-pressure LPG models must be adjusted to [Chapter 14](#) by trained and experienced personnel.

Use clean, fresh HD-5 grade liquefied petroleum gas (LPG) or equivalent product consisting of at least 90% propane. Commercial liquefied petroleum gas fuels may contain more than 2.5% butane, which can result in poor fuel vaporization and poor engine starting in low ambient temperatures below 32 °F (0 °C).

Satisfactory performance on low-pressure LPG models requires that the LPG vapor be supplied at a pressure within the range indicated in [Chapter 14](#).

3.4 Engine Oil Recommendations

Use API (American Petroleum Institute) performance Class **SJ**, **SH** or **SG** engine oil, which may be in combination with performance Class CH-4, CG-4 or CF-4 (for example: SJ/CH-4). Also look for the SAE (Society of Automotive Engineers) viscosity grade. Referring to the table below, choose the viscosity grade appropriate for the ambient temperatures expected until the next scheduled oil change.

Single-grade SAE 30 oil is preferable when temperatures are consistently above freezing. Multigrade oils are better when wide temperature variations are expected.

TABLE 1. OIL VISCOSITY VS. TEMPERATURE

Expected Ambient Temperatures	SAE Viscosity Grade
0 °C (32 °F) and higher	30
-12 °C to 38 °C (10 °F to 100 °F)	15W-40 (OnaMax™)
-18 °C to 27 °C (0 °F to 80 °F)	10W-30, 10W-40
-28 °C to 10 °C (20 °F to 50 °F)	5W-30

OnaMax is a trademark of Cummins.

3.5 Starting Batteries

The generator set has a 12 volt, direct current (DC) engine cranking and control system. See [Chapter 14](#) regarding minimum battery ratings for reliable generator set cranking, especially in cold weather.

3.6 Generator Set Control Panel

The generator set control panel ([Figure 2](#)) has the following features:

- **Control Switch** - This switch is used to prime the fuel system, start and stop the generator set, and display the shutdown code.
 - Hold the switch in its **START** position to crank and start the generator set.
 - Press the switch to its **STOP** position to stop the generator set.
 - Hold the switch in its **STOP/PRIME** position (starts priming in 2 seconds) to prime the fuel system (gasoline models only). See the Troubleshooting section about displaying fault codes.
- **Status Indicator Light** - This light is an LED (light emitting diode) in the control switch which blinks rapidly during cranking and comes on solid when the starter disconnects, indicating that the generator set is running. If the generator set shuts down abnormally, the light will blink a code to indicate the cause of the shutdown. See the Troubleshooting section.
- **Line Circuit Breaker** - The line circuit breaker protects the AC power leads connected to the generator set from overloads and equipment short circuits.
- **Hour Meter** (Models HGJAD and HGJAE only) - The hour meter records generator set operating time in hours. It cannot be reset. See the Periodic Maintenance Schedule ([Chapter 4](#)).

3.7 Remote Control Panel

Cummins offers three remote control kits as follows:

- Remote switch with status indicator light only ([Figure 3](#)).
- Remote switch with status indicator light and hour meter ([Figure 4](#)).
- Remote switch with status indicator light and DC voltmeter ([Figure 5](#)).

The hour meter records generator set operating time in hours. It cannot be reset. See the Periodic Maintenance Schedule ([Chapter 4](#)).

The DC voltmeter indicates whether voltage across the 12 VDC control system and battery is normal. If the indicator consistently stays above or below the normal zone, see Maintaining the Battery and Battery Connections ([Section 4.4](#)).

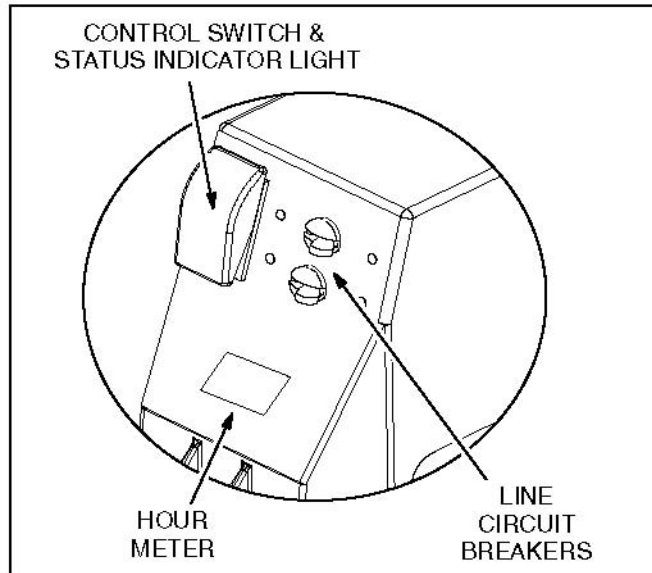

FIGURE 2. GENERATOR SET CONTROL PANEL

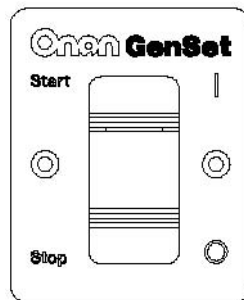

FIGURE 3. REMOTE SWITCH

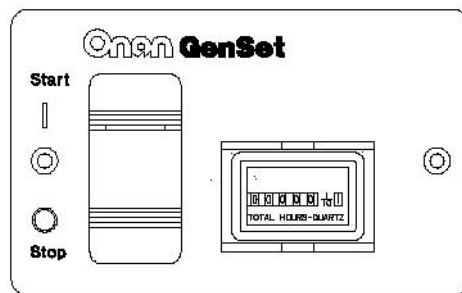

FIGURE 4. REMOTE SWITCH/HOUR METER

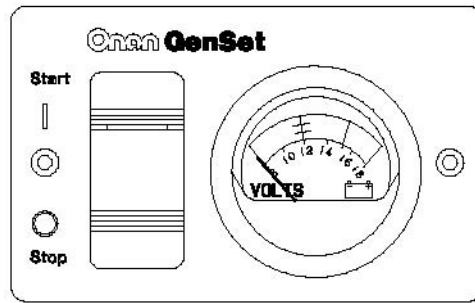

FIGURE 5. REMOTE SWITCH / DC VOLTMETER

⚠ WARNING

Exhaust Gas Is Deadly

Exhaust gases contain carbon monoxide, an odorless, colorless gas. Carbon monoxide is poisonous, and can cause unconsciousness and death. Symptoms of carbon monoxide poisoning include:

- ***Dizziness***
- ***Throbbing in temples***
- ***Nausea***
- ***Muscular twitching***
- ***Headache***
- ***Vomiting***
- ***Weakness and sleepiness***
- ***Inability to think clearly***

If you or anyone else experiences any of these symptoms, get out into the fresh air immediately. If symptoms persist, seek medical attention. Shut down the generator set and do not operate it until it has been inspected and repaired. Never occupy the vehicle with the generator set running unless the vehicle is equipped with a working carbon monoxide detector. However, primary protection against inhaling carbon monoxide is proper installation of the exhaust system, daily (every eight hour) inspection for visible and audible exhaust system leaks.

3.8 Conducting Pre-Start Checks

Before the first start of the day and after every eight hours of operation, inspect the generator set as instructed under Conducting General Inspections ([Section 4.1](#)). Keep a log of maintenance and the hours run and perform any maintenance that may be due.

Before each start:

1. Make sure all vehicle CO detectors are working.
2. Check for signs of fuel and exhaust leaks and for damage to the exhaust system.
3. To prevent overheating and to reduce fouling with dust and debris, make sure the generator set's normal ground clearance is not being reduced by sloping ground, curbs, logs or other objects. Repark the vehicle if necessary and/or remove any objects blocking the air inlet or air outlet.
4. Turn off the air conditioner and other large appliances.
5. If the generator set is equipped with a hydraulic pump, check and refill the oil reservoir as necessary.

3.9 Priming Gasoline Fuel Systems

If a gasoline generator set runs out of fuel, prime the fuel system by holding the control switch at **STOP/PRIME** for 30 seconds. (The status indicator light will stay on solid while the pump is on.)

3.10 Starting the Generator Set

Start the generator set from the generator set control panel or remote control panel inside the vehicle ([Section 3.7](#)).

1. Push and hold the switch at **START** until the generator set starts. The status indicator light on the switch flashes while cranking. It will come on solid when the starter disconnects, indicating that the generator set is running. (Because the generator set control has to "wake up," a slight delay might be noticed before anything seems to happen. On models with fuel injection, the delay could be up to 3 seconds to pressurize the fuel injectors.)
2. The generator set control will discontinue cranking if the generator set does not start within 30 seconds and will cause the status indicator light to blink Fault Code No. 4. Wait 5 seconds for the control to reset before trying again. See the Troubleshooting section if the generator set does not start after two or three tries.

CAUTION

Do not risk burning out the starter motor by continued attempts to start. Find out why the generator set is not starting and repair as necessary.

3. For top performance and engine life, especially in colder weather, let the engine warm up for two minutes before connecting appliances.
4. Check for fuel and exhaust leaks. Stop the generator set immediately if there is a fuel or exhaust leak and have it repaired.
5. Always secure the access cover after starting the generator set at the generator set control panel.

WARNING

Operating the generator set with the access cover off can lead to severe burns and overheating of components. Always secure the cover after starting the generator set.

3.11 Stopping the Generator Set

1. Turn off air conditioners and other large appliances.
2. Let the generator set run for two minutes to cool down before stopping. This reduces backfiring and run-on.
3. Press the switch to **STOP** to stop the generator set.

3.12 Restarting the Generator Set

See the Troubleshooting section if the generator set shuts down abnormally.

3.13 Engine Run Only Operation

Shutdowns due to an alternator failure can be bypassed when the generator set is restarted within one (1) minute of shutting down. While operating in this mode, the engine will run but the generator set will not create an AC output. The status indicator lamp flashes at a high frequency while operating in this mode. This feature allows the engine's hydraulic pump (optional) to run so that hydraulic systems powered by the engine can be operated though AC output has failed.

ERO operation is enabled when the generator set shuts down on the following fault codes:

- Overvoltage - Fault Code 12
- Undervoltage - Fault Code 13
- Overfrequency - Fault Code 14
- Underfrequency - Fault Code 15
- Voltage Sense Lost - Fault Code 27
- Low Cranking Speed Sense - Fault Code 32
- Invalid Set Configuration - Fault Code 37
- Field Overload (Over Voltage) - Fault Code 38
- Generator Rotor Fault - Fault Code 41
- Speed Sense Fault - Fault Code 45
- Field Sense Fault - Fault Code 48

3.14 Generator Set Lockout Switch (HGJAD and HGJAE Models Only)

The vehicle may be equipped with a generator set lockout switch in the cab and/or boom bucket that can be used to prevent unauthorized starting of the generator set. The switch(es) must be in their unlocked positions to start the generator set.

4 Periodic Maintenance Schedule

Periodic maintenance is essential for top performance and long generator set life. Use the table below as a guide for normal periodic maintenance. In hot and dusty environments, some maintenance procedures should be performed more frequently, as indicated by the footnotes in the table. Keeping a log of maintenance performed and hours run will help you keep generator set maintenance regular and provide a basis for supporting warranty claims.

Maintenance, replacement or repair of emission control devices and systems may be performed by any engine repair establishment or individual. However, warranty work must be completed by an authorized Cummins dealer.

TABLE 2. PERIODIC MAINTENANCE SCHEDULE

MAINTENANCE PROCEDURE	MAINTENANCE FREQUENCY						Section
	Every Day or Every 8 Hours	After First 20 Hours	Every Month	Every 50 Hours	Every 150 Hours	Every 500 Hours	
General Inspections	X						Section 4.1
Check Engine Oil Level	X						Section 4.2
Clean and Check Battery			X ³				Section 4.4
Clean Spark Arrestor				X			Section 4.7
Change Engine Oil & Oil Filter		X ¹			X ^{2, 3, 4}		Section 4.3
Replace Air Filter Element					X ²		Section 4.5
Replace Spark Plugs						X ⁵	Section 4.6
Clean Engine Cooling Fins						X ²	-
Replace Fuel Filter						X ^{5, 6, 7}	-
Adjust Valve Lash						X ⁶	-
1 - As a part of engine break-in, change the engine oil after the first 20 hours of operation. 2 - Perform more often when operating in dusty environments. 3 - Perform more often when operating in hot weather. 4 - Perform at least once a year. 5 - Perform sooner if engine performance deteriorates. 6 - Must be performed by a trained and experienced mechanic (authorized Cummins dealer). 7 - Replace every 500 hours or once every 3 years.							

4.1 Conducting General Inspections

Inspect the generator set before the first start of the day and after every eight hours of operation.

4.1.1 Oil Level

Check engine oil level ([Section 4.2](#)).

4.1.2 Exhaust System

WARNING

Exhaust Gas Is Deadly

Do not operate the generator set if there is an exhaust leak or any danger of exhaust gases entering or being drawn into the vehicle.

WARNING

Do not park the vehicle in high grass or brush. Contact with the exhaust system can cause a fire.

- Look and listen for exhaust system leaks while the generator set is running. Shut down the generator set if a leak is found; have it repaired before operating the generator set again.
- Look for openings or holes between the generator set compartment and vehicle cab or living space if the generator set engine sounds louder than usual. Have all such openings or holes closed off or sealed to prevent exhaust gases from entering the vehicle.
- Replace dented, bent or severely rusted sections of the tailpipe. Make sure the tailpipe extends at least 1 inch (25.4 mm) beyond the perimeter of the vehicle.
- Park the vehicle so that generator set exhaust gases disperse away from the vehicle. Barriers such as walls, snow banks, high grass and brush, and other vehicles can cause exhaust gases to accumulate in and around the vehicle.
- Do not operate power ventilators or exhaust fans while the vehicle is standing with the generator set running. The ventilator or fan can draw exhaust gases into the vehicle.
- Check all CO monitors to assure proper operation.

4.1.3 Fuel System

WARNING

Gasoline and LPG are highly flammable and explosive, and can cause severe personal injury or death. Shut down the generator set and repair leaks immediately.

- Check for leaks at the hose, tube and pipe fittings in the fuel supply and return systems while the generator set is running and while it is stopped. **Do not use a flame to check for LPG leaks.**
- Check the flexible fuel hose sections for cuts, cracks, and abrasions.
- Make sure the fuel line is not rubbing against other parts.
- Replace worn or damaged fuel line parts before leaks occur.
- If you smell gas, close the LPG container shutoff valve and have the generator set serviced before using it again.

4.1.4 Battery Connections

Check the battery terminals for clean, tight connections. Loose or corroded connections have high electrical resistance which makes starting harder. See Maintaining the Battery and Battery Connections ([Section 4.4](#)).

4.1.5 Mechanical

⚠ WARNING

Always wear safety glasses when using compressed air, a pressure washer or a steam cleaner to avoid severe eye injury.

- Look for mechanical damage. Start the generator set. Look, listen and feel for any unusual noises and vibrations.
- Check the generator set mounting bolts to make sure they are secure.
- Check to see that the generator set air inlet and outlet openings are not clogged with debris or blocked.
- Clean accumulated dust and dirt from the generator set. Do not clean the generator set while it is running or still hot. Protect the alternator, air cleaner, control panel, and electrical connections from water, soap and cleaning solvents.

4.2 Checking Engine Oil Level

Park the vehicle on level ground and shut off the generator set before checking the engine oil level.

⚠ WARNING

Crankcase pressure can blow hot engine oil out the fill opening causing severe burns. Always stop the generator set before removing the oil fill cap.

1. Unscrew the oil fill cap and wipe oil off the dipstick as shown in the figure below.

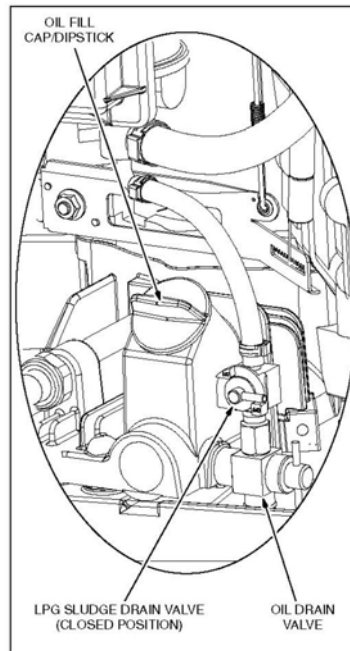

FIGURE 6. OIL FILL/DIPSTICK AND DRAIN VALVE

2. Screw the cap back on, remove it and check the oil level on the dipstick.
3. Add or drain oil as necessary. See Engine Oil Recommendations ([Section 3.4](#)). Keep the oil level between the FULL and ADD marks. The oil fills slowly because it takes time for the air in the crankcase to escape. Recheck the level in a few minutes to make sure.

⚠ CAUTION

Too much oil can cause high oil consumption. Too little oil can cause severe engine damage. Keep the oil level between the Full and Add marks.

4. Screw the oil fill cap back on securely.

4.3 Changing Engine Oil and Oil Filter

⚠ WARNING

State and federal agencies have determined that contact with used engine oil can cause cancer or reproductive toxicity. Avoid skin contact and breathing of vapors. Use rubber gloves and wash exposed skin.

Refer to [Table 2](#) for scheduled engine oil change. Change oil more often in hot or dusty environments.

1. Place a pan underneath the oil drain hose and filter, as shown in the figure below.

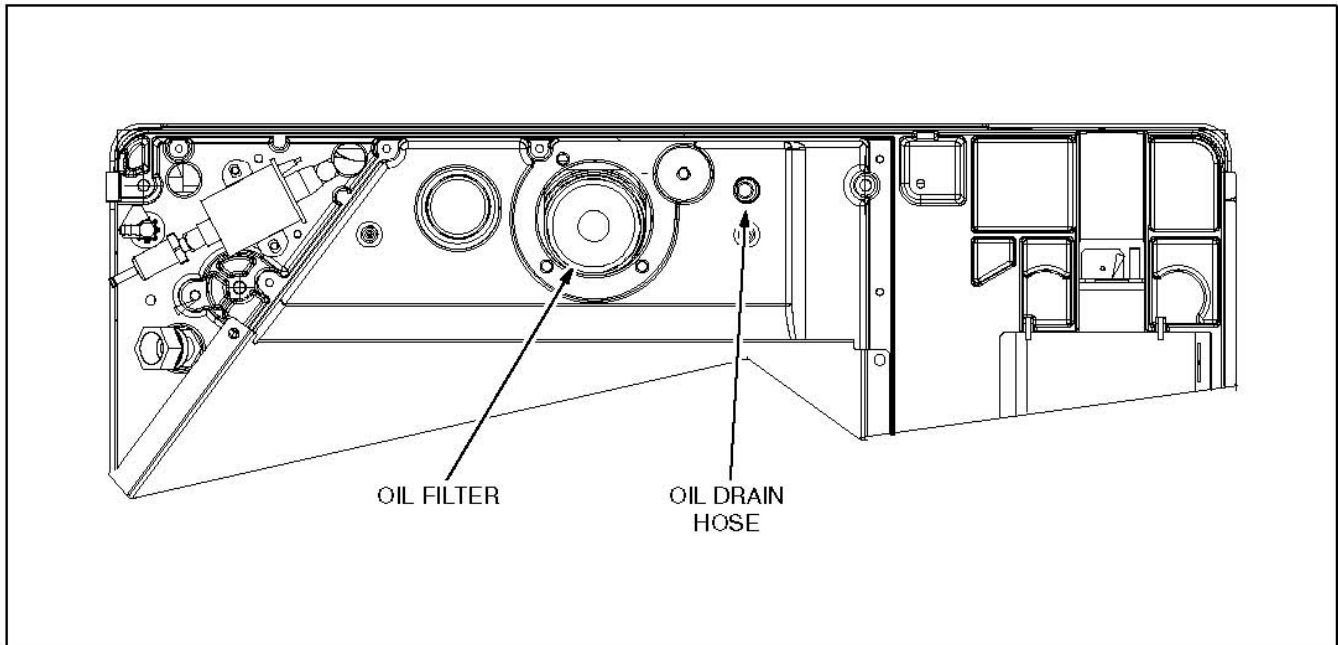

FIGURE 7. OIL FILTER AND DRAIN HOUSE (VIEW FROM BELOW THE GENERATOR SET FRONT EDGE)

2. Run and then stop the engine when it is warm.

⚠ WARNING

Crankcase pressure can blow hot engine oil out the fill opening causing severe burns. Always stop the generator set before removing the oil fill cap.

3. Remove the oil fill cap.
4. Open the oil drain valve ([Figure 6](#)).
5. Let all oil drain from the engine.
6. Close the drain valve.
7. *High pressure LPG generator sets only:*
 - a. Drain the LPG system of accumulated sludge by opening the sludge drain valve ([Figure 6](#)). Oil-like sludge can migrate from the LPG supply system during operation, and if allowed to accumulate, can cause hard starting and rough running. The sludge drains out through the engine oil drain hose.
 - b. Make sure to re-close the valve to keep out dust and to keep the engine running smoothly.
8. Spin off the old oil filter.
9. Thoroughly wipe off the filter mounting surface.
10. Remove the old gasket if it does not come off with the filter.
11. Apply a film of oil to the filter gasket and spin the new filter on by hand until the gasket just touches the mounting pad.
12. Turn it no more than 1/2 to 3/4 turn.
13. Refill with 2 quarts (1.8 L) of oil. See Engine Oil Recommendations ([Section 3.4](#)). Check and add or drain oil as necessary.

⚠ CAUTION

Too much oil can cause high oil consumption. Too little oil can cause severe engine damage. Keep the oil level between the Full and Add marks.

Oil fills very slowly. Take your time and check level often while filling. It takes time for the air in the crankcase to escape and allow oil to enter.

14. Dispose of the used oil and oil filter in accordance with local environmental regulations.

4.4 Maintaining the Battery and Battery Connections

⚠ WARNING

Arcing at the battery terminals or light switch or other equipment or flames and sparks can ignite battery gas causing severe personal injury:

- *Ventilate the battery area before working on or near battery.*
- *Wear safety glasses.*
- *Do not smoke.*
- *Switch the trouble light ON/OFF away from battery.*
- *Do not disconnect battery cables while generator set is running or vehicle battery charging system is on.*
- *Always disconnect the negative (-) cable first and reconnect it last.*

Refer to [Table 2](#) for scheduled battery maintenance, and follow the battery manufacturer's instructions. Have the battery charging system serviced if DC system voltage is consistently low or high. Always:

1. Keep the battery case and terminals clean and dry, and the terminals tight.
2. Remove the battery cables with a battery terminal puller.
3. Make sure which terminal is positive (+) and which is negative (-) before making battery connections, always removing the negative (-) cable first and reconnecting it last to reduce arcing.

4.5 Replacing the Air Filter Element

Refer to [Table 2](#) for scheduled air filter element replacement. In dusty environments the filter element should be inspected and changed more frequently. To change the filter element ([Figure 8](#)):

1. Unlatch the three spring clips and rotate the cover out and away from the hooks on top. Remove the air filter element.
2. Wipe the filter element sealing surfaces clean and reassemble the air filter with a new filter element.

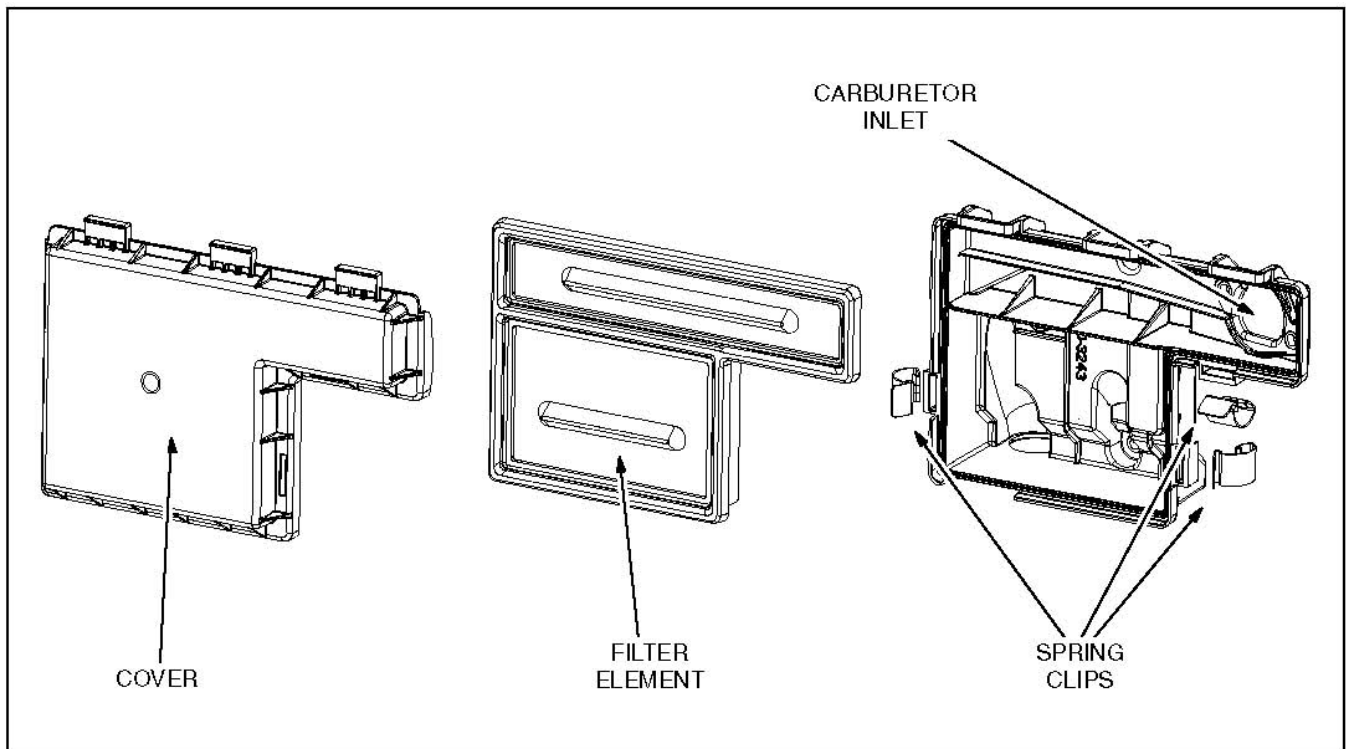

FIGURE 8. REPLACING THE AIR FILTER ELEMENT

4.6 Replacing Spark Plugs

Refer to the Periodic Maintenance section for scheduled spark plug replacement. The generator set has two spark plugs, as shown in the figure below. The spark plugs must be in good condition for proper engine starting and performance. A spark plug that fouls frequently or has heavy soot deposits indicates the need for engine service. See the Troubleshooting section.

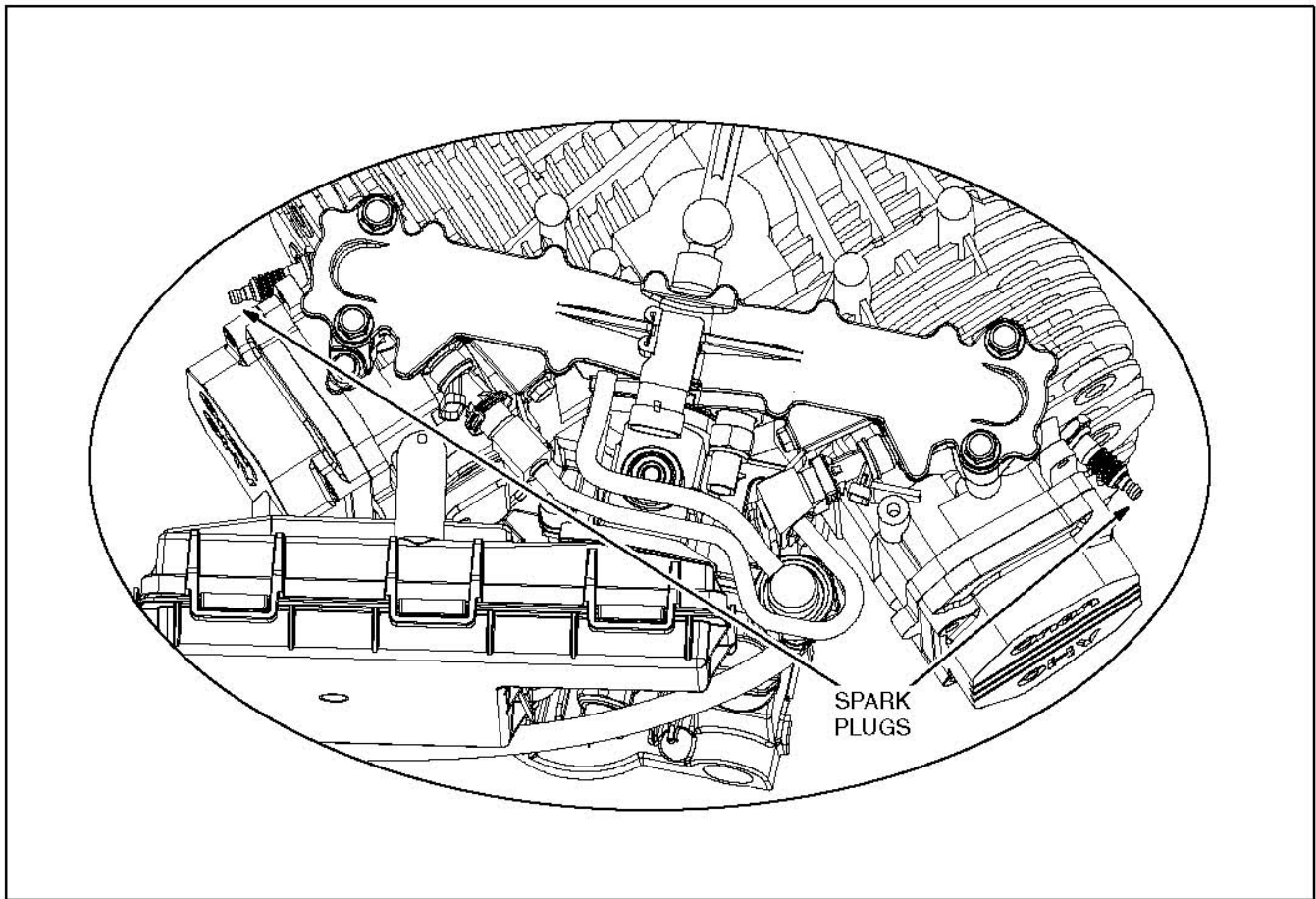

FIGURE 9. SPARK PLUGS

To prevent cross threading, always thread a spark plug in by hand until it seats and then torque to 13 Nm (10 lb-ft) if new, or to 24 Nm (18 lb-ft) if being reused.

4.7 Cleaning the Spark Arrestor

Refer to [Table 2](#) for scheduled cleaning of the spark arrestor muffler. Cleaning is required for maximum generator set performance. *Park the vehicle away from grass, brush or debris that could be ignited by sparks expelled during this procedure.*

⚠ WARNING

A hot muffler can cause severe burns. Let the muffler cool down before removing or installing cleanout plugs or screens.

HGJAA and HGJAD models only: A muffler is mounted inside the generator set. The cleanout plug is in the drum, but accessible from below, though not readily visible.

1. Locate the square-headed cleanout plug by hand.
2. Solidly seat a 7/16 inch, *eight point*, 3/8 inch drive socket wrench with 3 inch extension on the plug.
3. Add a swivel section and 6 inch extension.
4. Turn with a ratchet to remove the plug.
5. Start and load the generator set to near full power.

6. Let the generator set run for about five minutes to expel the soot in the muffler.
7. Stop the generator set.
8. Allow the muffler to cool down.
9. Reinstall the plug.

HGJAB and HGJAE models only: On a single-drum muffler, the cleanout plug is accessible from below as shown in the figure below.

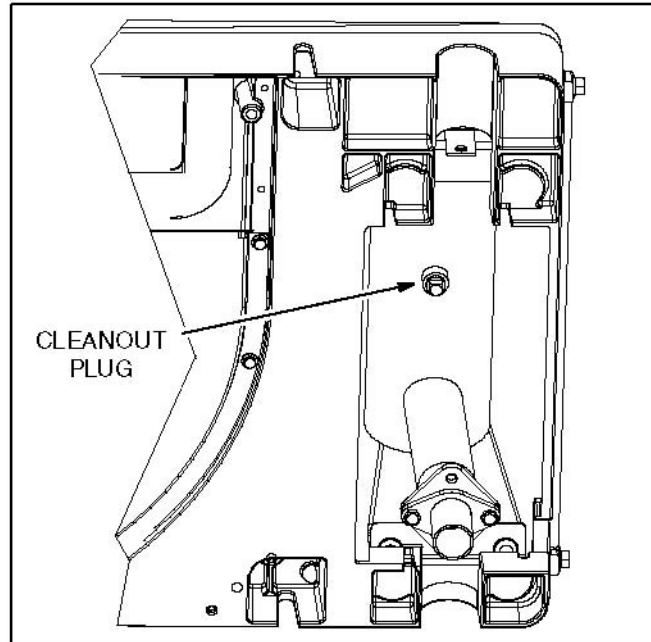

FIGURE 10. HJGAB AND HGJAE CLEANOUT PLUG (VIEW FROM BELOW)

4.8 Cleaning Cylinder Heads

1. Inspect cylinder head and ensure all measurements are within tolerances listed in Dimensions and Clearances [Section 10.9](#).
2. Move first cylinder to be cleaned to TDC.
3. Cover push rod ports with masking tape to protect from debris while cleaning [Figure 11](#).
4. Clean piston top and top of engine block with rotating Scotch-Brite pad. For difficult deposits a rotating steel wire brush may be used. Avoid use of steel brush on gasket mating surfaces [Figure 12](#).
5. Wipe down all surfaces with degreaser.
6. Move cylinder to BDC and clean any deposits or cleaning debris from crown of piston bore with Scotch-Brite pad. Be careful not to damage piston-ring travel area, do not touch this area with abrasive material.
7. Repeat steps 1 through 5 for cleaning second cylinder.
8. Remove intake and exhaust valves.
9. Secure cylinder head in a bench vise, being careful not to over-tighten. A vise with soft jaws is preferred for this operation.
10. Clean combustion chamber and surface of head with rotating steel wire brush.

11. Wipe down all surfaces with degreaser clean ports and valve guides with compressed air.
12. Repeat steps 7 through 9 for second cylinder head.
13. Follow procedure for Reassembly and Installation of cylinder head and valves on [Section 10.7](#), including lapping the intake and exhaust valves.
14. Complete reinstallation of intake and exhaust manifolds, ensuring all fasteners are tightened to the proper torque specifications.



FIGURE 11. PUSH ROD PORTS WITH MASKING TAPE

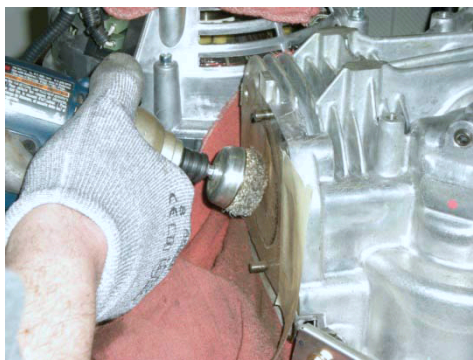

FIGURE 12. PISTON CLEANING

5 Preparing for Service

5.1 Troubleshooting

Refer to the Troubleshooting section before starting work on the generator set. Note that some problems have several possible causes.

5.2 Safety

There are hazards in servicing generator sets. Study *Safety Precautions* and become familiar with the hazards listed in [Table 3](#). Note the following safeguards and ways of avoiding hazards:

- **Use personal protection:** Wear appropriate protective safety equipment, such as safety shoes and safety glasses.
- Do not wear rings or jewelry and do not wear loose or damp clothing that might get caught in equipment or conduct electricity.
- **Reduce the hazard:** A safe, orderly workshop area and well-maintained equipment reduce the hazard potential. Keep guards and shields in place on machinery and maintain equipment in good working condition. Store flammable liquids in approved containers; away from fire, flame, spark, pilot light, switches, arc-producing equipment and other ignition sources. Keep the workshop clean and well-lighted and provide adequate ventilation.
- **Develop safe work habits:** Unsafe actions cause accidents with tools and machines. Be familiar with the equipment and know how to use it safely. Use the correct tool for the job and check its condition before starting. Comply with the warnings in this manual and take special precautions when working around electrical equipment. Do not work alone if possible and take no risks.
- **Be prepared for an accident:** Keep fire extinguishers and safety equipment nearby. Agencies such as the Red Cross and public safety departments offer courses in first aid, CPR and fire control. Take advantage of this information to be ready to respond to an accident. Learn to be safety-conscious and make safety procedures part of the work routine.

TABLE 3. HAZARDS AND THEIR SOURCES

Hazard	Sources
Fire and Explosion	<ul style="list-style-type: none">• Leaking or spilled fuel• Hydrogen gas from battery• Oily rags improperly stored• Flammable liquids improperly stored
Burns	<ul style="list-style-type: none">• Hot exhaust pipes• Hot engine and generator surfaces• Electrical shorts
Poisonous Gas	<ul style="list-style-type: none">• Operating generator set where exhaust gases can accumulate
Electrical Shock (AC)	<ul style="list-style-type: none">• Improper generator connections• Faulty wiring• Working in damp conditions• Jewelry touching electrical components
Rotating Machinery	<ul style="list-style-type: none">• Fan guards not in place

Hazard	Sources
Slippery Surfaces	• Leaking or spilled oil
Heavy Objects	• Removing generator set from vehicle • Removing heavy components

5.3 Special Tools

The following special tools are required to service the generator set:

1. InPower Harness Kit (Spec J and later) (0541-1374)
2. Bypass Control Board Tester (0420-0603)
3. Bypass Control Board Tester Adapter Kit (0541-1143)
4. Harness Kit for InPower Diagnostic Service Tool (0541-1287)
5. Harness Kit for InPower Diagnostic Service Tool (0541-1389)

See the Cummins Tool Catalog.

5.3.1 Engine Tools

- Torque wrench (0-75 lb-ft or 0-100 Nm)
- Feeler gauge
- Leak down tester
- Spark plug gap gauge
- Cylinder compression tester
- Flywheel puller
- Snap ring pliers
- Cylinder ridge reamer
- Piston ring compressor
- Piston ring spreader
- Cylinder hone
- Valve seat cutter
- Valve spring compressor
- Piston groove cleaner
- Outside micrometer set (1-4 in)
- Telescoping gauge set (0.500-4.000 in)
- Hole gauge (0.300-0.400 in)
- Plasti-Gage bearing clearance guide

5.3.2 Alternator Tools

- Lead or dead-blow hammer
- VOM multi-tester
- Frequency meter

- Load test panel and leads

5.4 Removing the Generator Set Overview

Due to the wide variety of installations, it is not possible to provide specific procedures for removal. Contact the coach manufacturer or installer for their recommendations if it is unclear how the generator set is to be removed.

- **Below-Floor Mounting:**
 - Four 3/8 inch bolts into the ends or bottom of the base ([Figure 13](#)) are used to secure the generator set to special brackets from the vehicle floor, frame, or to frame members underneath ([Figure 13](#)).
 - The area above the generator set should have a vapor-tight, fire-resistive barrier between the generator set and coach interior.
- **Above-Floor, Compartment Mounting:**
 - Four 3/8 inch bolts into the bottom of the base ([Figure 13](#)) are used to secure the generator set to the floor of the compartment.
 - The compartment should have a vapor-tight, fire-resistive barrier that seals off the generator set from the coach interior.

5.4.1 Disconnecting the Generator Set

Disconnect battery, wiring, exhaust and fuel connections as follows before removing the generator set.

1. Disconnect all battery cables, negative (-) cable first, at the battery terminals.

WARNING

Arcing at battery terminals or light switch or other equipment or flames and sparks can ignite battery gas causing severe personal injury.

- ***Ventilate battery area before working on or near battery.***
- ***Wear safety glasses.***
- ***Do not smoke.***
- ***Switch trouble light ON/OFF away from battery.***
- ***Do not disconnect battery cables while the generator set is running or the vehicle battery charging system is on.***
- ***Always disconnect the negative (-) cable first and reconnect it last.***

2. Disconnect the negative (-) and positive (+) battery cables at the generator set.
3. Disconnect the wiring connectors for remote control and remote fuel pump (fuel injection models).
4. Disconnect the generator AC output wires and conduit from the junction box on the vehicle.
5. Disconnect the exhaust tail pipe.
6. **Gasoline-fueled generator sets:**
 - a. Disconnect the fuel line(s) from the generator set.
 - b. Securely plug the end of the fuel line to prevent leakage or an accumulation of explosive gasoline vapor.

7. LPG-fueled generator sets:

- a. Close the fuel shutoff valve(s) at the LPG container(s).
- b. Move the vehicle outside and away from below-grade spaces where LPG could accumulate.
- c. To purge most of the LPG from the fuel line and generator set, run the generator set (if it starts) until it runs out of fuel (LPG container valve closed).
- d. Disconnect the fuel line from the generator set.
- e. Plug the end of the hose to prevent fuel from escaping if someone inadvertently opens the shutoff valve(s) at the LPG container(s).

⚠ WARNING

Gasoline and LPG (liquefied petroleum gas) are flammable and explosive and can cause severe personal injury or death.

- ***Do not smoke.***
- ***Keep flames, sparks, pilot lights, arc-producing and switching equipment, and all other sources of ignition away from the fuel tank and system, and areas sharing ventilation. Have an ABC fire extinguisher handy.***

⚠ WARNING

LPG is flammable and explosive and can cause asphyxiation. NFPA 58, Section 1.6 requires all persons handling LPG to be trained in proper handling and operating procedures.

LPG "sinks" and can accumulate in explosive concentrations. Before disconnecting the LPG fuel line, close the fuel shutoff valve(s) at the LPG container(s) and move the vehicle outside and away from pits, basements, and other below-grade spaces where LPG could accumulate.

5.4.2 Removing the Generator Set

1. Park the vehicle on a level surface.
2. Put the transmission in PARK.
3. Lock the brakes.
4. Remove the ignition key. Do **not** move the vehicle during this procedure.

⚠ CAUTION

The underside of the generator set can be damaged by protruding objects. Always rest the generator set on a flat surface that has been cleared off. Always extend the lifting arms of a forklift beyond the base of the generator set to prevent them from protruding into the underside cover.

Figure 13 illustrates the four lift-hook slots for generator set lifting. A lifting rig must spread the hook straps such that they do not crush or bend parts such as the control box, air filter and fuel lines while lifting. See the Specifications section regarding the weight of the generator set and make provisions accordingly for safe handling.

⚠ CAUTION

Avoid tipping the front (service side) down while handling the generator set. Otherwise, engine oil could drain into and soak the air filter and cause hard starting and poor operation unless the filter is replaced.

5.5 Installing the Generator Set

Generally, installation is the reverse of removal. Before installing the generator set, repair any damage to and seal all holes in the vapor-tight, fire-resistive barrier between the generator set and coach interior. Make sure all mounting bolts and brackets are secure and that all battery, AC output, control, exhaust, and fuel connections are proper and in good repair. Perform the service checklist before placing the generator set in service ([Chapter 13 Service Checklist](#)).

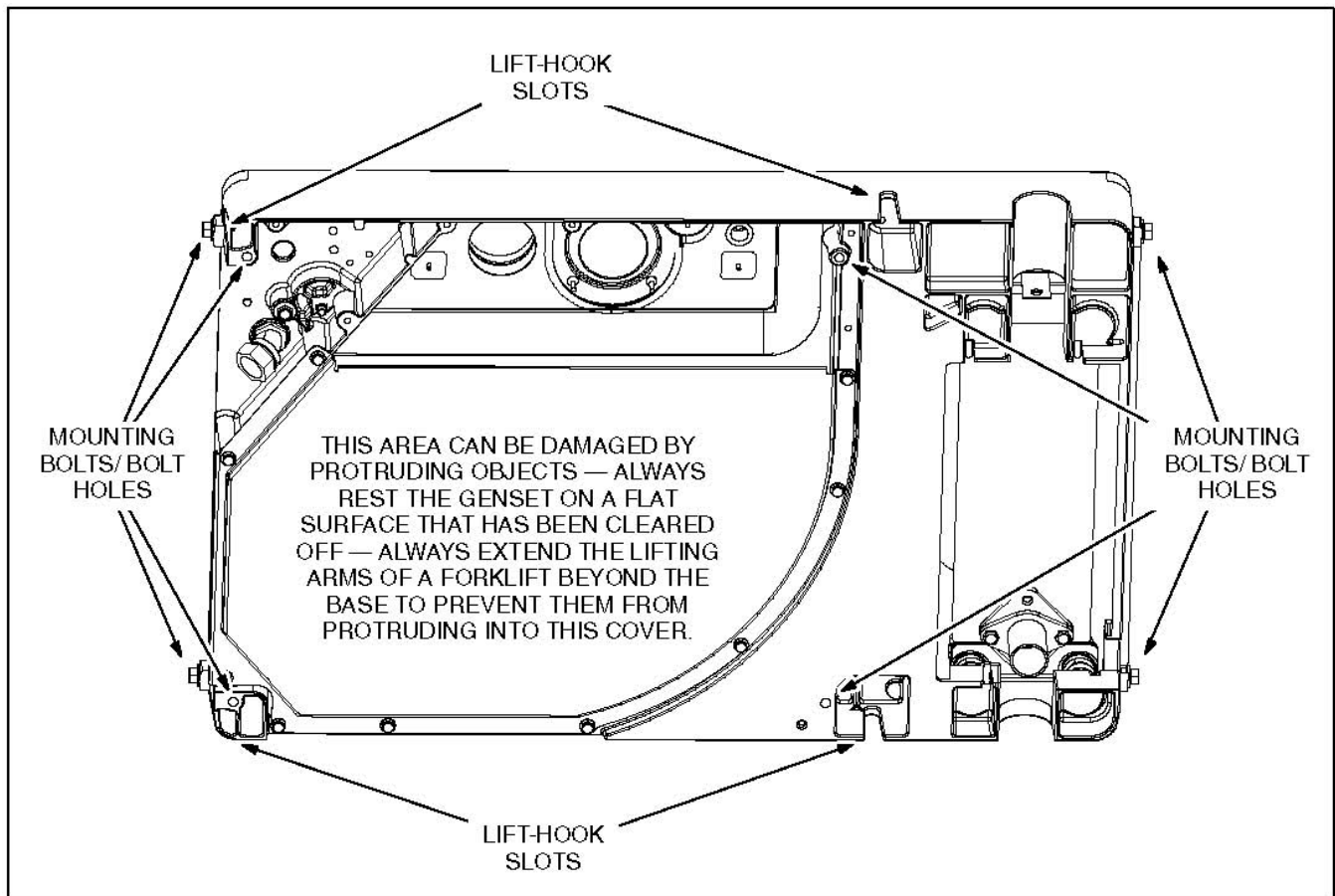

FIGURE 13. GENERATOR SET LIFT-HOOK SLOTS (MOUNTING BOLT HOLES) AREA THAT CAN BE DAMAGED

This page is intentionally blank.

6 Control

6.1 Controller A1

Controller A1 is an integrated microcontroller-based engine and generator set control ([Figure 14](#)). It provides all the control, monitoring and diagnostic functions required to operate the generator set. All connections to the controller are through connector J1 on the side of the controller. Refer to the appropriate wiring diagrams and wiring harness drawings.

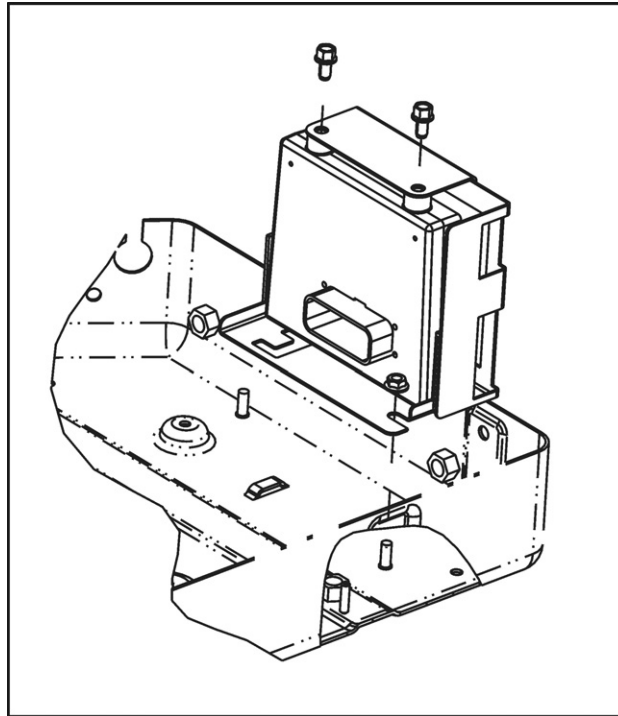

FIGURE 14. CONTROLLER A1

6.1.1 Major Functions of Controller A1

The figure below is a block diagram of controller functions.

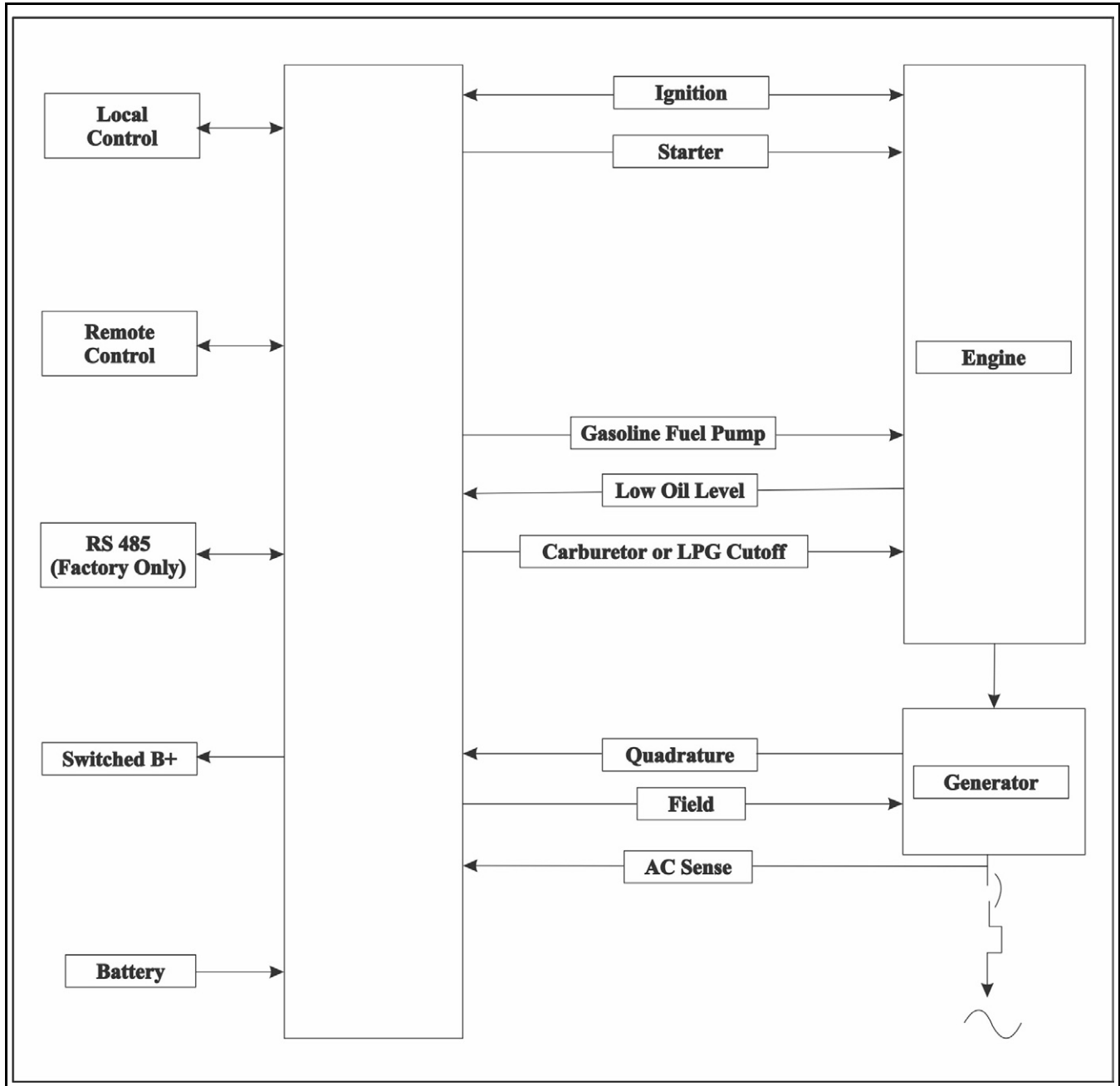

FIGURE 15. CONTROLLER A1 BLOCK DIAGRAM

Initialization: Control initialization consists of checking memory (RAM, ROM, EEPROM) and generator set configuration.

Fuel Prime (Gasoline Generator Sets): Press and hold the stop switch for more than 3 seconds to cause the fuel pump to prime the fuel system.

Startup: Press and hold the start switch until the generator set starts. The controller:

1. Enables cranking.
2. Energizes the fuel pump E2 (gasoline models only).

3. Depending on model:
 - a. Enables fuel injection
 - b. Energizes the gasoline carburetor fuel cutoff solenoid E3 and choke heater
 - c. Energizes LPG fuel cutoff solenoid E3.
4. Flashes the field (F1-F2).
5. Flashes the status indicator light during cranking.
6. Disconnects the starter when engine speed is greater than 1300 rpm and turns the status indicator light on solid.
7. Turns on Switched B+ (remote pin J8-F).
8. Enables output voltage two seconds after operating speed is reached.
9. Turns off field flash.

Stop: Press the stop switch momentarily. The controller:

1. Disables output voltage.
2. De-energizes the fuel pump and fuel cutoff solenoid or fuel injectors.
3. Enables ignition kill.
4. Turns off the status indicator light.
5. Writes session data (number of cranks, minutes of operation, last fault, etc.) to non-volatile memory (NVM).
6. Removes processor power when idle 5 minutes (15 minutes, HGJAA and HGJAD).

NOTICE

Stop takes precedence over Start if both are present due to a faulty switch or other cause.

Fuel Control: See the Gasoline Fuel System section.

Voltage Control: The controller maintains nominal AC output voltage during steady state operation by varying field current as load varies. In response to transient loads it lowers the voltage setpoint to allow engine recovery. Field power (DC) is supplied by the quadrature windings (AC) through the controller.

6.1.2 Controller A1 Removal/Replacement

To remove the controller:

1. Remove the enclosure.
2. Remove the controller bracket.
3. Use a small flat-bladed screwdriver to lever out the catch on Connector P1/J1.
4. Pull the connector apart.

6.2 Other Control Components

6.2.1 Control Switch S1

The control switch is located as shown.

1. Unsnap connector P9 from the back of the switch for access to its terminals.

2. Replace the switch if one of the following is true:
 - It does not close across terminals 2 and 3 when the switch is held in the Start position.
 - It does not close across terminals 1 and 2 when held in the Stop position.
 - The status indicator light does not light when 12 VDC is connected across terminals 7 (-) and 8 (+).

6.2.2 Line Circuit Breakers CB1

The line circuit breaker is located as shown.

1. Disconnect all wiring.
2. Check electrical resistance across the terminals of the circuit breaker.
3. Replace a circuit breaker that does not:
 - Reset, or
 - Close or open as the handle is turned ON and OFF.

6.2.3 Hour Meter

If the generator set is equipped with an hour meter, it is located on the remote panel.

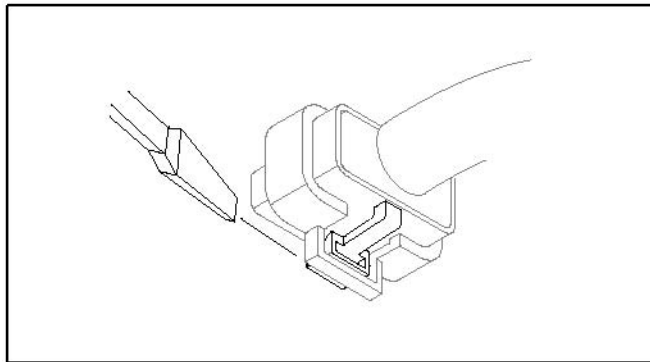

FIGURE 16. DISCONNECTING P1/J1

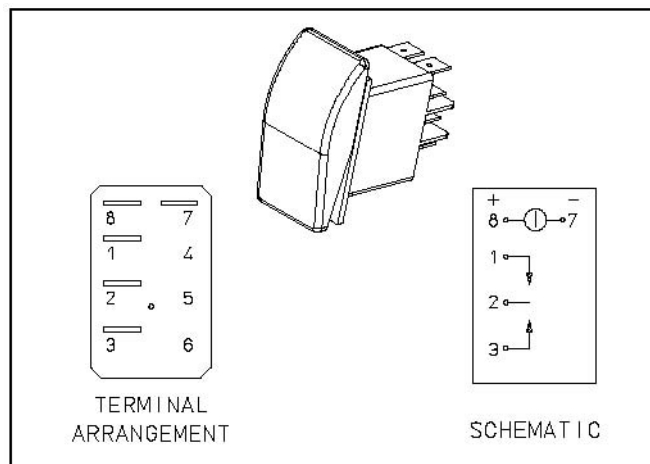

FIGURE 17. CONTROL SWITCH S1

6.2.4 3-Phase Voltage Sense Transformer

Mounting: The voltage sense transformer for 3-phase generators is mounted as shown (Figure 18). It is connected to sense output voltage in L1.

Testing: Replace the transformer if resistance in either winding is not as specified in the schematic.

6.2.5 Battery Charge Regulator

Mounting: When the generator set is so equipped, the regulator and heat sink are mounted as shown on the engine-alternator mounting base (Figure 19).

Testing: Test battery charge winding B1-B2 and the battery charge regulator.

1. Disconnect the wire from K1 B+ terminal on the battery charge regulator.
2. Measure the output from the battery charge windings, B1-B2. The output should be between 15 and 20 VAC. Repair the alternator as necessary if the voltage is not within the specification.
3. If the B1-B2 output voltage is between 15 and 20 VAC, measure the DC output voltage at the K1 B+ terminal on the battery charge regulator.
4. If the DC output voltage is less than 12.8 VDC, replace the battery charge regulator.

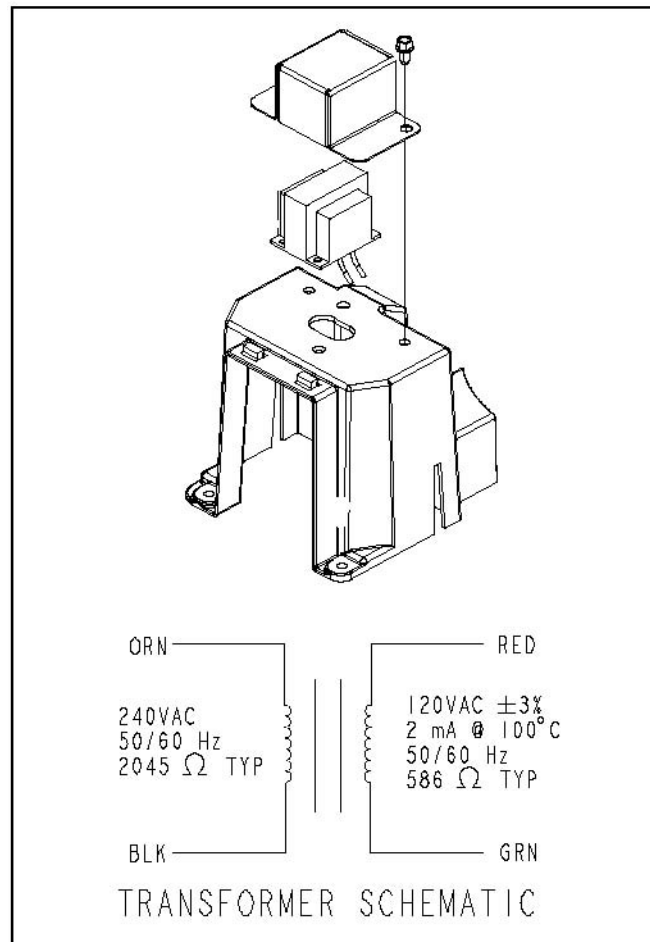

FIGURE 18. 3-PHASE VOLTAGE SENSE TRANSFORMERS

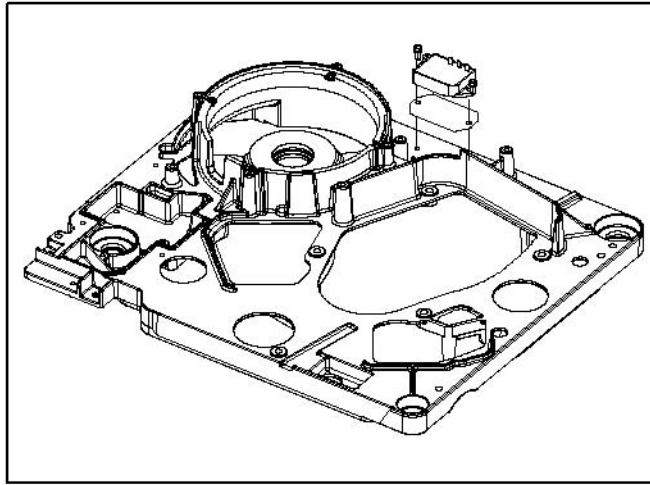

FIGURE 19. BATTERY CHARGE REGULATOR VR

6.2.6 Alternator DC Grounds

Secure the three GND wiring harness eyelets ([Appendix A](#)) to the base on a stud with a nut ([Figure 21](#)).

6.2.7 Alternator Neutral Ground Screw

For 2-wire, 120 VAC generator sets only ([Figure 29](#)): Secure alternator leads T2 and T4, the green AC output lead, and the two (2) white (L0 and L0) AC output leads to the base with the alternator neutral ground screw ([Figure 21](#)).

6.2.8 Bond Strap

Connect the bond strap ([Figure 21](#)) between the alternator/engine base and drip pan to carry control and cranking currents to battery negative (-). The negative battery cable terminal is on the bottom side of the drip pan ([Figure 26](#)).

6.2.9 Remote Control Connector P2/J2

The following image illustrates the sealed 8-pin connector for remote control.

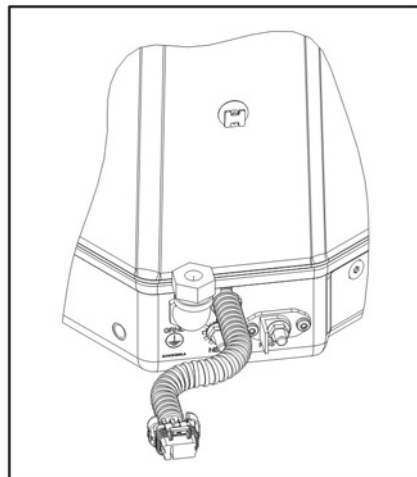

FIGURE 20. 8-PIN CONNECTOR

6.2.10 Fuel Pump Connector

[Figure 22](#) illustrates the sealed 2-pin remote fuel pump connector for models HGJAA and HGJAD. Instead, models HGJAB and HGJAE generator sets have, two (2) separate quick-connects for connection directly to the leads of the mounted gasoline fuel pump ([Section 9.2.9](#)) or LPG shutoff solenoid ([Section 9.3](#)).

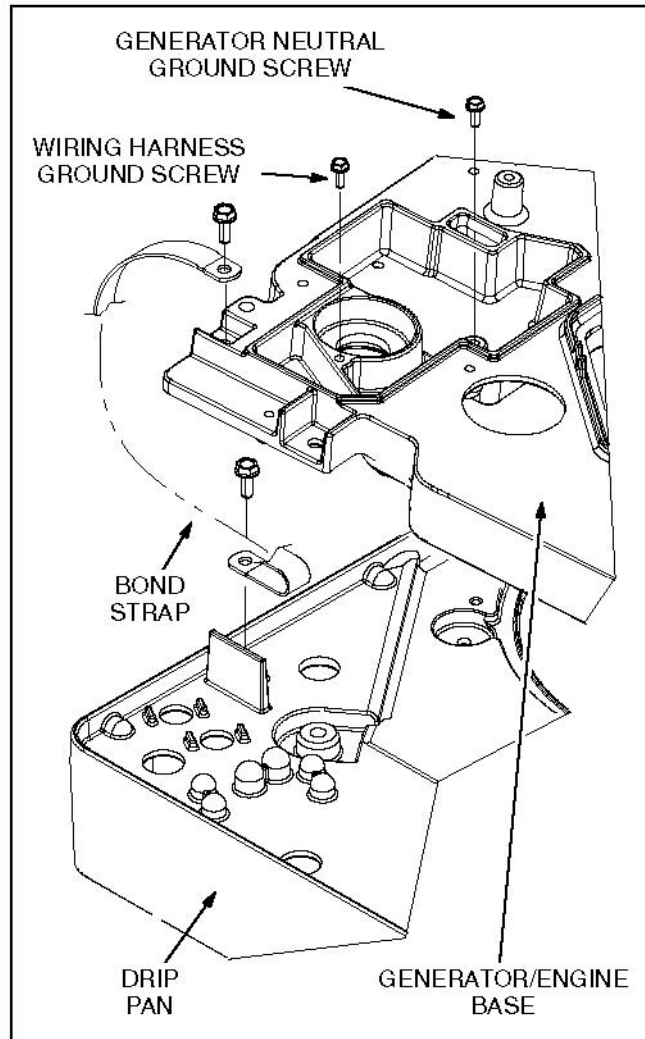

FIGURE 21. BOND STRAP

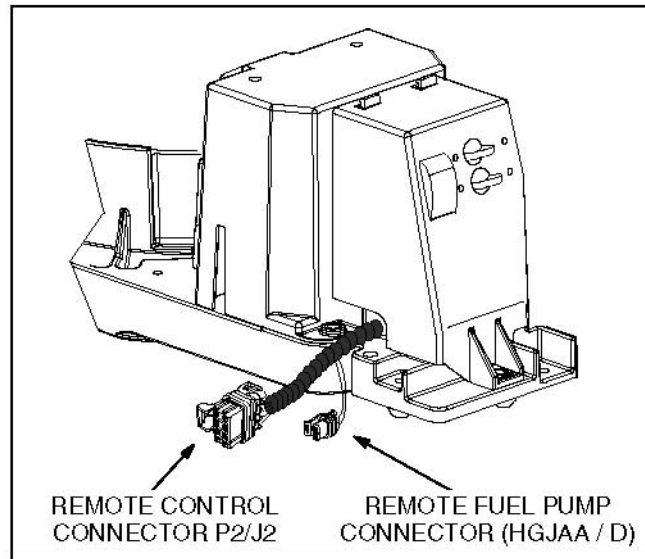

FIGURE 22. REMOTE CONNECTORS

6.2.11 Batteries

The generator set has a 12 VDC, negative-ground engine control and cranking system. See the Specifications section for the requirements for cranking batteries.

6.2.12 Battery Cables

If battery cables need to be replaced, size them according to [Table 4](#). The current path between the generator set and the negative (-) battery terminal must be able to carry full cranking current without causing excessive voltage drop. The path may be a full-length cable ([Figure 23](#)) or the vehicle frame ([Figure 24](#)). Note also that a generator set grounding conductor, if provided, was probably required by code and must be reconnected to the grounding terminal ([Figure 25](#)).

NOTICE

The generator set mounting bolts are not considered adequate means for bonding the generator set to the vehicle frame, either for the purpose of carrying cranking currents or for complying with requirements for generator set/system grounding.

When replacing battery cables route them away from fuel lines and hot engine exhaust components. Battery cables should be accessible for inspection and replacement, protected from damage and secured to prevent chafing due to vibration.

⚠ WARNING

Routing battery cables with fuel lines can lead to fire and severe personal injury or death. Keep battery cables away from fuel lines.

TABLE 4. BATTERY CABLE SIZES* FOR TEMPERATURES DOWN TO -20 °F (-29 °C)

Length in Feet (Meters)	Size
0 to 45 (0 to 13.7)	2**
46 to 60 (14 to 18.3)	0
61 to 80 (18.6 to 24.4)	00

* Battery cable lengths are total lengths from battery to the alternator back to the battery and when using a total of 1000 CCA (Cold Cranking Amps).
 ** A total length of up to 20 feet (6 meters) may be used in warmer climates or when battery capacity totals at least 1000 CCA.

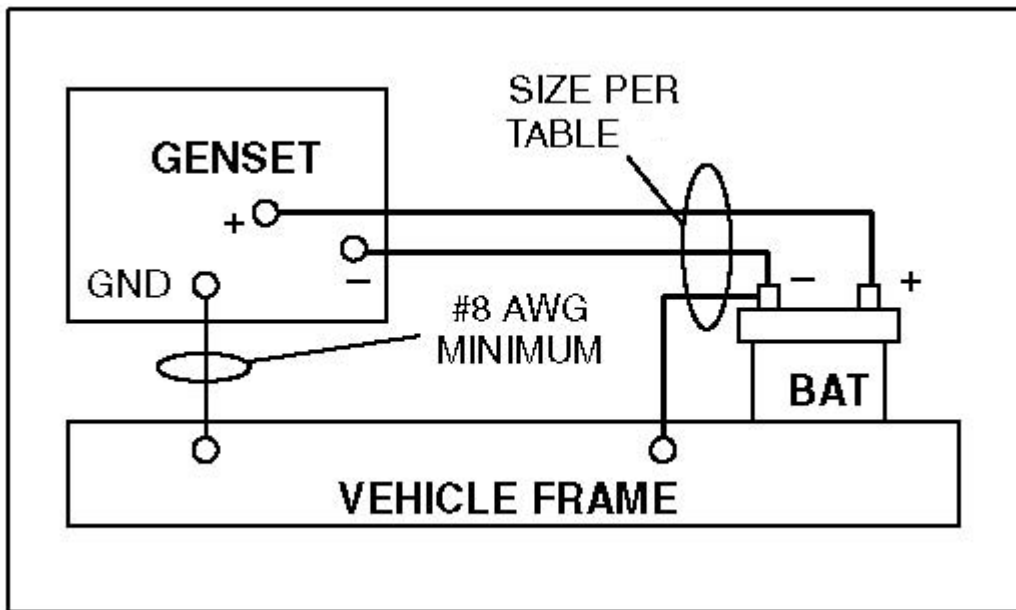

FIGURE 23. FULL-LENGTH CABLE FROM BATTERY NEGATIVE (-) TERMINAL

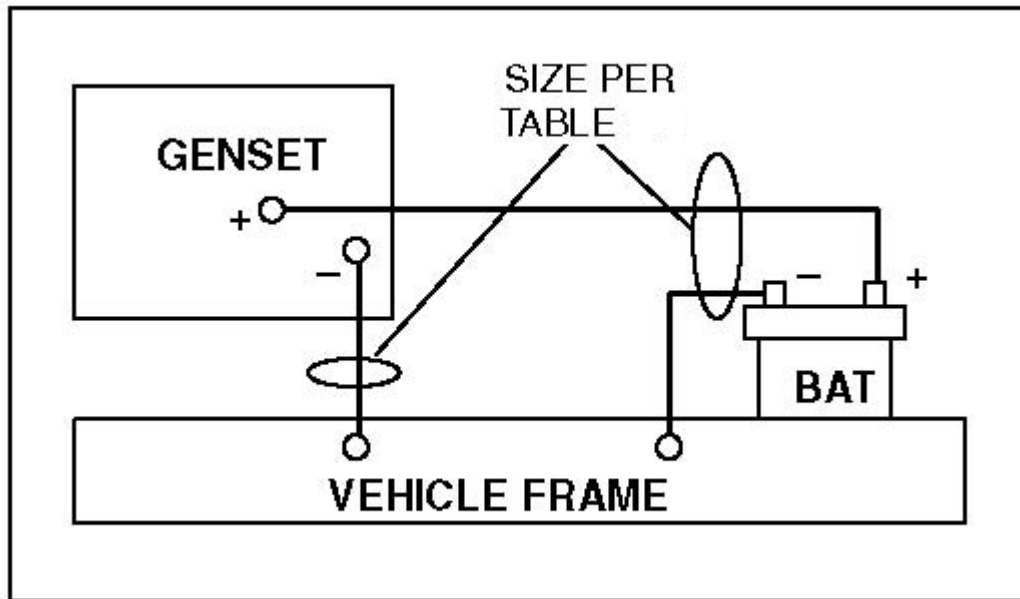

FIGURE 24. VEHICLE FRAME AS PATH FROM BATTERY NEGATIVE (-) TERMINAL

6.2.13 Battery Cable Connections at Generator Set

1. Terminate the battery cables with ring terminals sized for 5/16 inch screws.
2. Connect them to the generator set as shown in [Figure 25](#) and [Figure 26](#).
3. Secure the insulating boot on the positive (+) terminal.
4. Tie it to the battery cable with a tie wrap.

6.2.14 Generator Set (Equipment) Grounding Screw

When required, connect the generator set grounding screw to the vehicle frame with a No. 8 AWG or larger stranded cable having a ring terminal sized for a 3/8 inch screw.

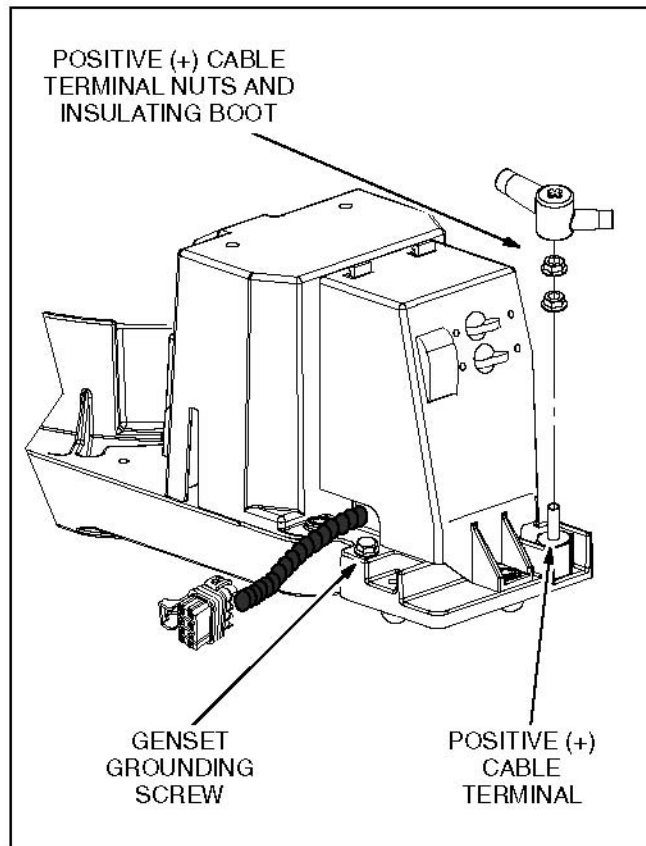

FIGURE 25. POSITIVE (+) BATTERY CABLE TERMINAL AND GENERATOR SET GROUNDING SCREW

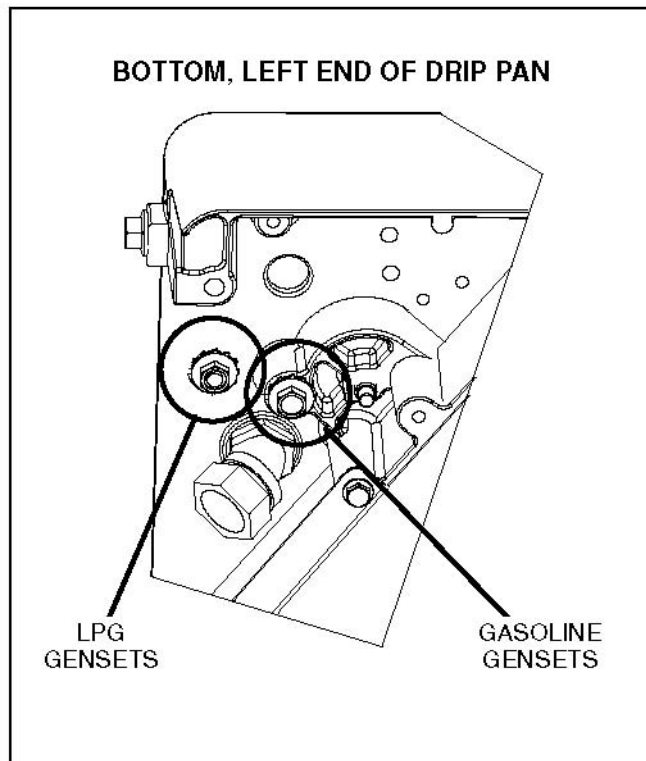

FIGURE 26. NEGATIVE (-) BATTERY CABLE TERMINAL

This page is intentionally blank.

7 Generator

7.1 Alternator Description

These are vertical-shaft, 2-bearing, belt-driven, 2-pole, revolving field alternators with brushes and slip rings, as shown in the figure below. The output voltage is regulated by microcontroller-based generator set controller A1.

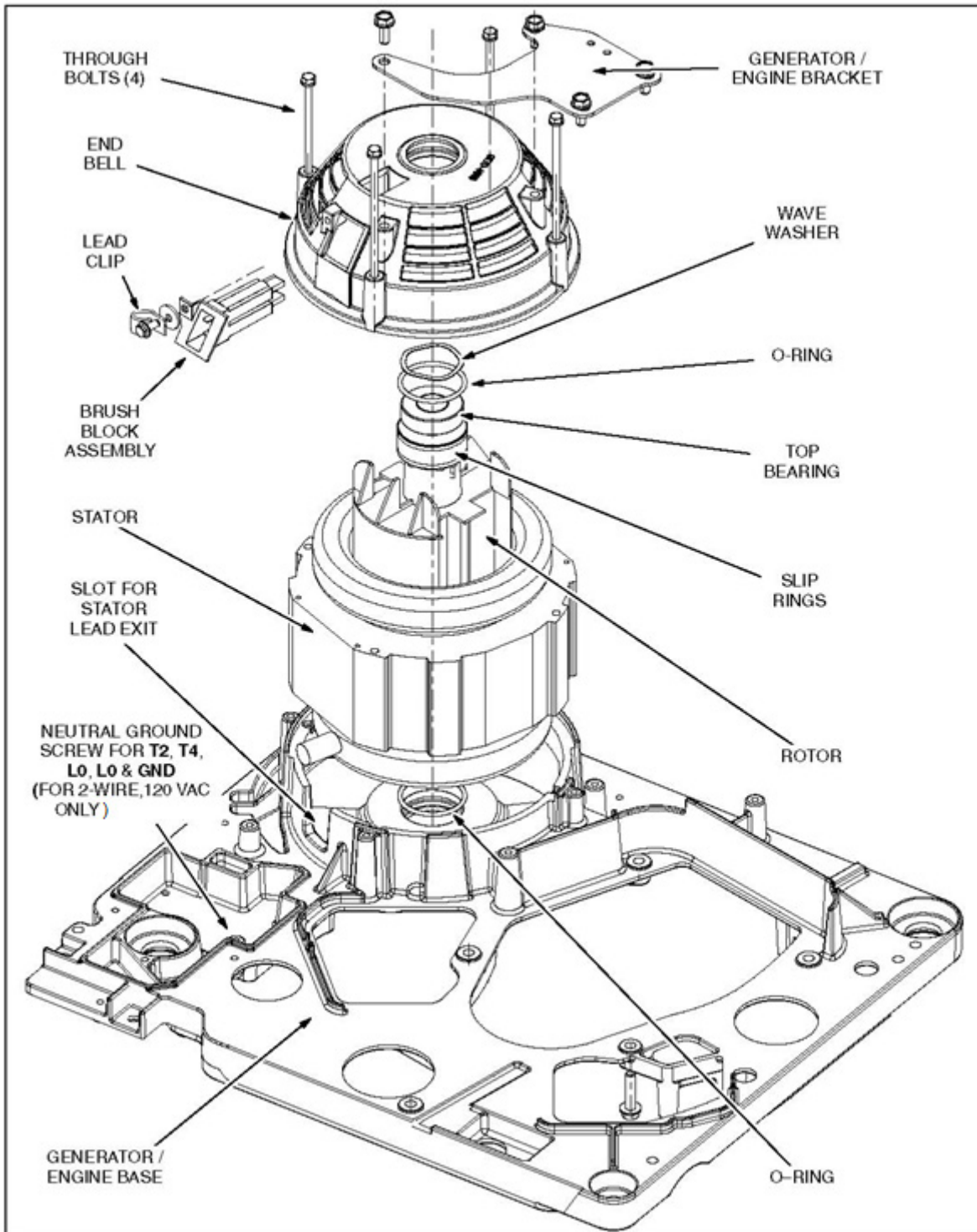

FIGURE 27. ALTERNATOR

7.1.1 Stator

The stator consists of steel laminations with two or three sets of windings in the lamination slots. The main windings (T1-T2, etc.) power the connected loads and the quadrature windings (Q1-Q2) supply power for the generator field. Some models have battery charging windings (B1-B2). See connection diagram in [Figure 27](#).

7.1.2 Rotor

The rotor consists of a shaft with steel laminations wrapped with field windings. A molded slip ring assembly is pressed on to supply field current to the rotor windings through the brush block assembly. The rotor shaft is supported on both ends by sealed ball bearings and is driven by a belt pulley.

7.1.3 Generator Set Cooling Fan

The generator set cooling fan (blower) is bolted to the generator drive pulley to cool the alternator and engine.

7.1.4 Brush Block

Field current passes through the brush block which has two spring-loaded carbon brushes that make contact with the rotor slip rings.

7.1.5 Voltage Regulator

Generator set controller A1 maintains constant output voltage under varying load conditions by varying field current. Power for field excitation is supplied by the quadrature winding (Q1-Q2).

7.1.6 Line Circuit Breakers

Line circuit breakers (CB1, CB2, and CB3) are mounted on the control panel to protect the alternator leads and provide a means for disconnecting the alternator from the load. See the [Figure 27](#) schematics.

7.1.7 Principle of Operation

During start-up, the controller enables field flashing by means of battery current for fast build-up of alternator voltage as the engine accelerates to operating speed. During operation, the controller maintains nominal AC output voltage by varying field current in response to load. In response to transient loads, it lowers the voltage setpoint to allow engine recovery. The quadrature windings supply field power through the controller.

7.2 Alternator Service

The alternator brush block, end bell and stator ([Figure 31](#)) can be removed from the top of the alternator/engine base, leaving the rotor in place. It is necessary to remove the rotor drive pulley before the rotor can be pulled up out of the base. To remove the rotor drive pulley see [Chapter 8 Drive Belt System](#).

7.2.1 Stator Removal

1. Remove the two-piece control enclosure ([Chapter 6](#)) and disconnect the stator leads from the line circuit breakers and neutral (grounded) terminal on the base.
2. Remove the brush block ([Section 7.3.1](#)).

⚠ CAUTION

The brushes can be damaged if the brush block is not removed before removing the end bell.

3. Remove the alternator/engine bracket.
4. Remove the four alternator through bolts.

5. Pull the alternator end bell straight up.
6. Pull the stator assembly straight up, taking care not to damage rotor or stator windings.

7.2.2 Stator Reassembly

Reassembly is the reverse of removal.

1. Align the stator so that the leads exit through the slot in the base.
2. Re-lubricate the bearing bore in the end bell with molybdenum disulfide paste or equivalent.
3. Make sure the wave washer and O-ring are in place in the bearing bore.
4. Torque the through bolts to 8 lb-ft (11 Nm).

7.2.3 Rotor Removal

1. Remove the rotor drive pulley. See [Chapter 8](#).
2. Remove the alternator end bell.
3. Pull the rotor assembly up, taking care not to damage rotor or stator windings.

7.2.4 Rotor Reassembly

Reassembly is the reverse of removal.

1. Re-lubricate the bearing bores in the end bell and base with molybdenum disulfide paste or equivalent.
2. Make sure the wave washer is in place in the end bell, and that the O-rings are in place in the top and bottom bearing bore grooves.
3. *For Spec A through C original rotors only:*
 - a. Use an adhesive when installing new bearings on the rotor shaft.
 - b. Apply the adhesive to the shaft (Loctite 680 or equivalent) and primer (activator) to the bearing (Loctite 747 or equivalent).
 - c. After applying adhesive, if necessary, press each bearing on up to its shaft shoulder using a bench press.

NOTICE

Apply force only to the bearing inner race to avoid damage to the bearing.

7.3 Brushes and Slip Rings

7.3.1 Brush Block

1. Disconnect the field leads from the brush block ([Figure 28](#)).
2. Remove the mounting screw.
3. Withdraw the brush block from the alternator end bell.
4. Replace the brush block assembly if either brush is shorter than 7/16 inch (11 mm), binds in the brush block, or is damaged in any way.
5. Reconnect the field leads, **F-** to the top terminal, and **F+** to the bottom terminal when reassembling.

6. Make sure the leads pass through the lead clip ([Figure 27](#)) to prevent strain on the terminals.

7.3.2 Slip Rings

1. Remove the brush block.
2. Inspect the slip rings for grooves, pits, or other damage.
3. Use a Scotch Brite pad or commutator stone to remove light wear or corrosion.

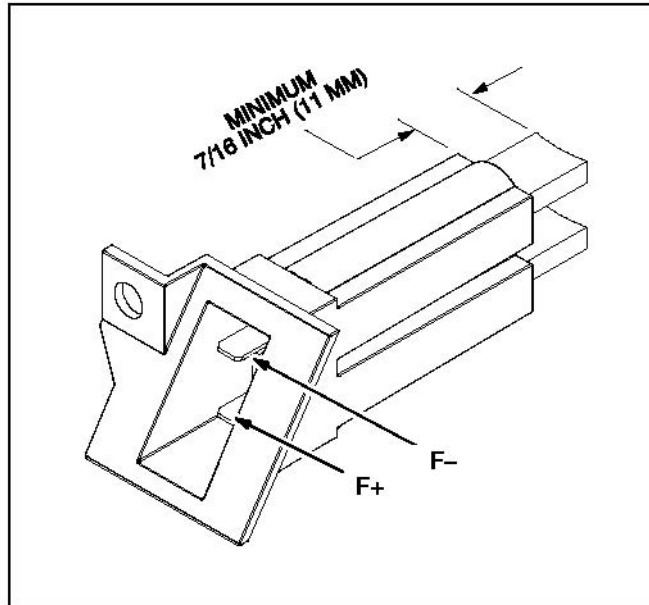

FIGURE 28. BRUSH BLOCK

7.4 Alternator Testing

7.4.1 Rotor Tests

Grounded, Open and Shorted Windings Test

1. Using an ohmmeter, test the rotor for grounded, open and shorted windings at the brush block terminals.
2. If the resistance is high, remove the brush block and test directly on the slip rings.
3. Replace the brush block if a high resistance is due to the brushes.

Ground Test

1. Set the ohmmeter to the highest resistance scale, or use a megger.
2. Touch one test prod to the rotor shaft and the other to one of the slip rings.
3. Replace the rotor if the reading is less than one megohm (one million Ohms) on a megger, or infinity on an ohmmeter.

Winding Resistance Test

1. Touch the slip rings with the meter test prods.
2. Replace the rotor if resistance is not as specified in the table below, as appropriate.

TABLE 5. ROTOR RESISTANCE AT 77° F (25° C) ± 10%

Models	Generator Set	Ohms
HGJAA and HGJAB	5.8-7.0 kW (95 mm Stack)	31.97
	5.5 kW Generator Sets (80 mm Stack)	29.34
HGJAD and HGJAE	----	31.97

7.4.2 Stator Tests

Use an ohmmeter to test for grounded or open windings. Remove the control enclosure for access to the stator leads ([Chapter 6](#)).

Ground Test

1. Set the ohmmeter to the highest resistance scale.
2. Touch one test prod to the stack and, in turn, the other to each stator lead.
3. Replace the stator if any reading is less than one megohm (one million Ohms) on a megger, or infinity on an ohmmeter.

Open Winding Test

1. Connect the ohmmeter test prods across each pair of winding leads.
2. Replace the stator if any winding is open (zero Ohms).

Winding Resistance Test

1. Use a meter (Wheatstone Bridge) having a precision down to 0.001 Ohms to measure resistance across each pair of winding leads.
2. Replace the stator if resistance is not as specified in the tables below, as appropriate.

TABLE 6. STATOR RESISTANCE AT 77 °F (25 °C) ± 10% (HGJAA AND HGJAB MODELS)

Winding	5.8-7.0 kW Generator Sets (95 mm Stack) (Ohms)	5.5 kW Generator Sets (80 mm Stack) (Ohms)
T1-T2, T3-T4	0.30	0.33
Q1-Q2	2.44	2.73

TABLE 7. STATOR RESISTANCE AT 77 °F (25 °C) ± 10% (HGJAD AND HGJAE MODELS)

Alternator	Winding	Ohms
120 V, 1-PH	T1-T2	0.147
	Q1-Q2	2.42
	B1-B2	0.124
120/240 V, 1-PH	T1-T4*	0.588
	Q1-Q2	2.42
	B1-B2	0.124

Alternator	Winding	Ohms
3-PH (DELTA)	L1-L2, L1-L3, L2-L3	1.05
	Q1-Q2	3.28
	B1-B2	0.276
* T2 and T3 must be connected for this test.		

7.5 Voltage Adjustments

⚠ WARNING

Hazardous Voltage

Touching uninsulated live parts inside the generator set or connected equipment can result in severe personal injury or death. For your protection, stand on a dry wooden platform or rubber insulating mat, make sure your clothing and shoes are dry, remove jewelry from your hands and use tools with insulated handles.

NOTICE

If a fault shutdown occurs or the control switch is pressed to **STOP** during voltage set mode, voltage adjustments will not be stored in controller memory.

NOTICE

All specs of HGJAA and HGJAD are capable of voltage adjustment, but only specs J and later of HGJAB and HGJAE are capable of voltage adjustment.

Voltage is adjusted by means of the control switch. Rapidly pressing the switch to **START** 6 times **during the first minute after startup** puts the generator set controller into voltage set mode. The amber status indicator lamp will begin blinking once every second to confirm voltage set mode.

To adjust voltage:

1. Disconnect all alternator loads.
2. Connect accurate meters to measure AC volts and frequency.
3. Start the generator set and let voltage and frequency stabilize for 5 to 10 seconds.
4. Rapidly press the control switch to **START** 6 times within 1 minute of start.
5. **To adjust voltage up**, press the control switch to **START** and release quickly. Each time the switch is released, the voltage will rise approximately 0.6 V.
6. **To adjust voltage down**, press the control switch to **START** and release in approximately 2 seconds. Each time the switch is released, voltage will drop approximately 0.6 V.

Normal operation will resume 20 seconds after the last adjustment, which remains as the voltage set point until changed again.

7.6 Alternator Connections

The generator set is equipped with circuit breakers and 12 AWG leads for AC power output, which exit through a rain-tight 1/2 inch trade size conduit connector. See [Figure 29](#) for the connection diagrams and the location of the conduit connector.

These generator sets are not reconnectable for voltages other than what is stated on the nameplate.

If the alternator leads are replaced, their ampacity must be equal to or greater than the ampere rating marked on the generator set circuit breakers. (Unless 125 °C rated wiring is available, heavier gauge wiring may be required to obtain the required ampacity.)

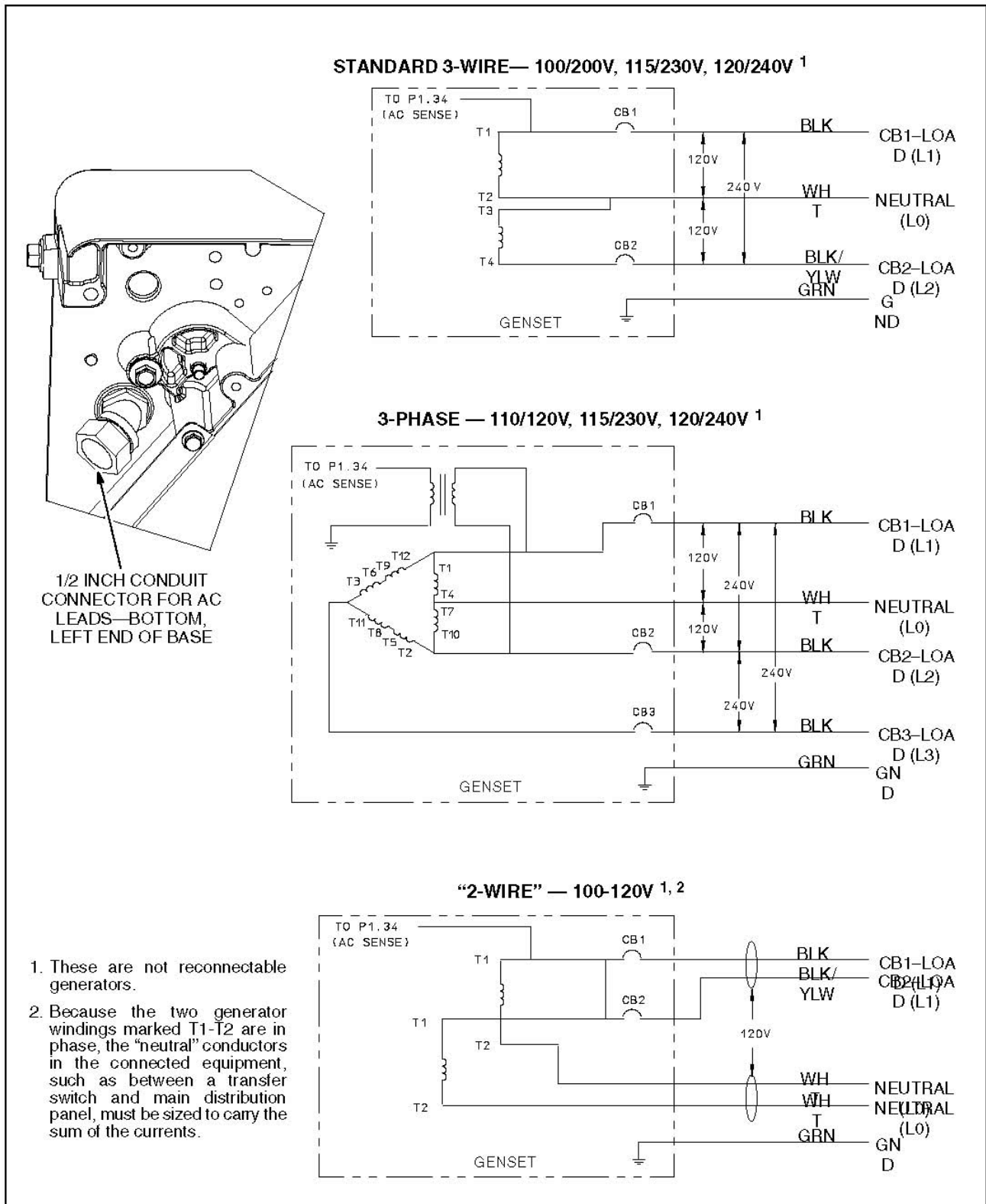

FIGURE 29. CONNECTION DIAGRAMS AND AC LEAD OUTLET

This page is intentionally blank.

8 Fan, Drive Belt, Flywheel, Ignition, and Exhaust

The fan shroud (Figure 30) on the underside of the generator/engine assembly encloses the cooling fan, belt drive, flywheel, ignition coils (magnetos) and exhaust manifold.

8.1 Fan, Belt, Pulleys and Flywheel

The engine drives the alternator by means of a 4-rib "Poly-Vee" belt (Figure 31). The engine pulley is coupled to the engine side of the flywheel, which is center-bolted and keyed to the engine crankshaft taper. The cooling fan and backplate are bolted directly to the alternator pulley, which is center-bolted to the alternator rotor shaft taper. The various alternator/engine speed combinations tabulated in the Specifications section are obtained by using various pulley ratios.

The alternator pulley must be removed before removing the alternator rotor shaft, and the flywheel assembly to remove the engine.

8.1.1 Removing Fan and Alternator Pulley

1. Remove the alternator/engine assembly from the generator set. See the Removing/Installing Alternator/Engine Assembly section.
2. Remove the eight fan shroud bolts and remove the fan shroud (as shown in the figure below).

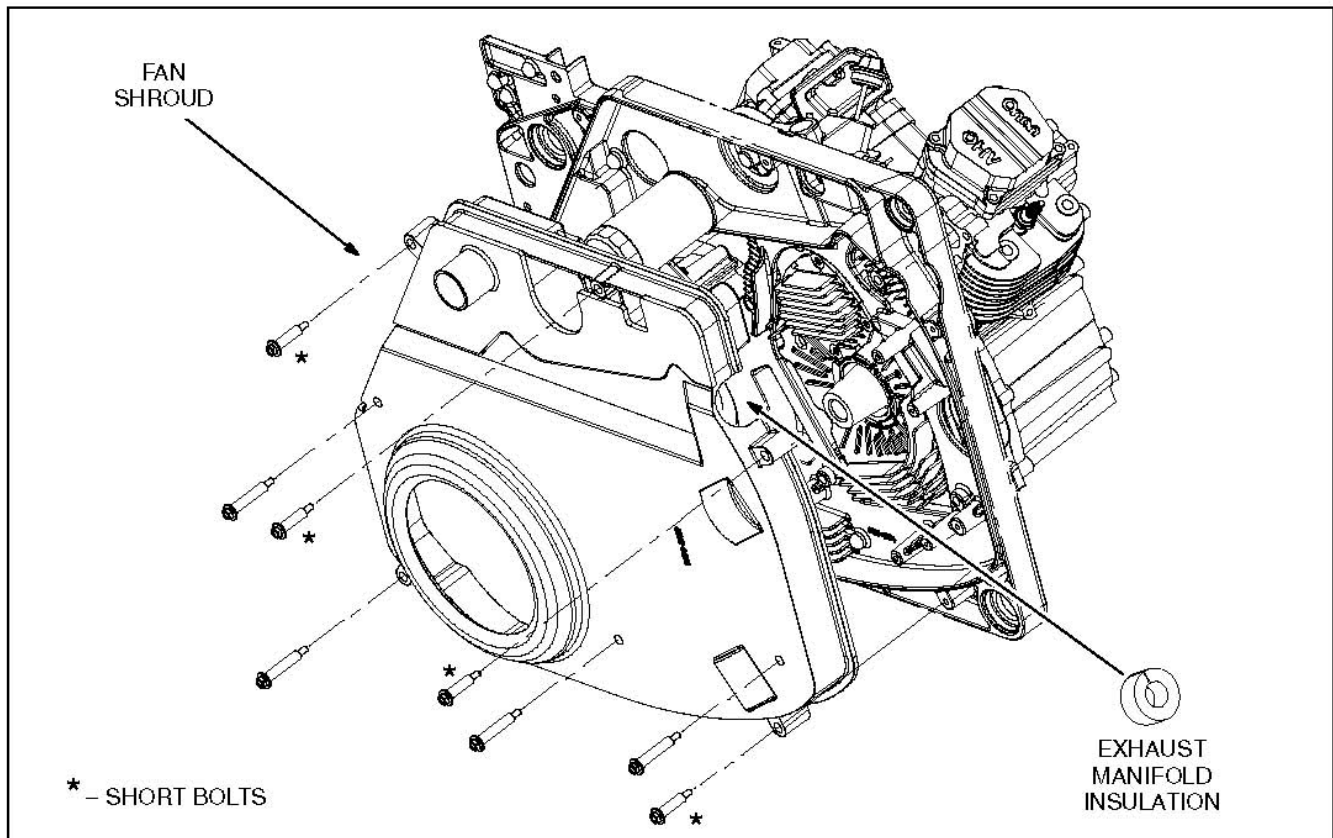

FIGURE 30. FAN SHROUD

3. Remove the three bolts securing the fan (blower) and its back plate ([Figure 31](#)) and remove them from the pulley.
4. Block the alternator pulley.
5. Remove the center bolt.
6. Use a wheel puller to break the pulley free of the alternator shaft taper. Three M6 bolt tappings are provided on the face for pulling.
7. Turn the belt tensioner away from the belt with a 1/2 inch socket driver.
8. Block it there while lifting off the alternator pulley.

8.1.2 Removing Flywheel and Engine Pulley

1. Remove the alternator/engine assembly from the generator set. See the Removing/Installing Alternator/Engine Assembly section.
2. Remove the eight fan shroud bolts and remove the fan shroud ([Figure 30](#)).
3. Remove the two ignition coils. See [Section 8.2.3](#).
4. Remove the four nuts in the face of the flywheel that secure the pulley coupling to the flywheel ([Figure 31](#)). (Otherwise, it will be necessary to remove the alternator pulley to seat the belt back on both pulleys.)
5. Block the flywheel from turning.
6. Remove the center bolt.
7. Use a wheel puller to break the flywheel free of the crankshaft taper. Two M10 bolt tappings are provided on the face for pulling.
8. Secure the crankshaft taper key so that it will not fall out.
9. Turn the belt tensioner away from the belt with a 1/2 inch socket driver and block it there while lifting off the flywheel.

8.1.3 Removing Tensioner Pulley

1. Remove the fan and alternator pulley ([Section 8.1](#)) so that the belt tensioner arm assembly can swing over and relieve the spring tension.
2. Remove the center bolt.

8.1.4 Reassembling Pulleys and Flywheel

1. Install the belt tensioner assembly if it has been removed.

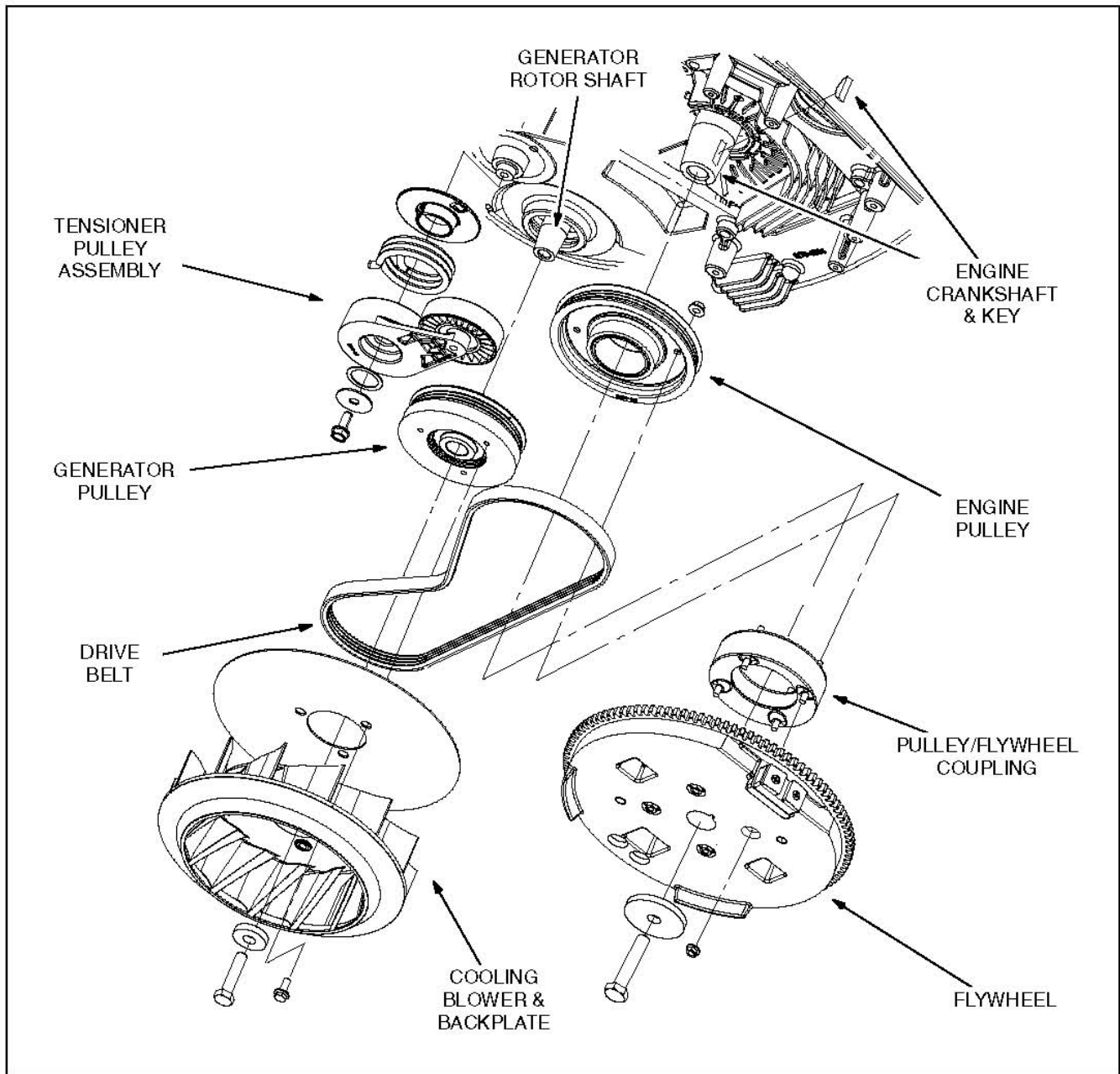

FIGURE 31. BELT DRIVE

2. Torque the center bolt to 20 lb-ft (27 Nm).
3. Turn the belt tensioner away from the belt with a 1/2 inch socket driver and block it there while seating the belt on the pulleys.
4. **If only the alternator pulley has been removed and the belt is still around the engine pulley:**
 - a. Wrap the belt around the alternator pulley and install the pulley on its shaft.
 - b. Check to see that the belt is properly seated in its grooves in both pulleys.
 - c. Secure the fan and its backplate.
 - d. Torque the alternator pulley center bolt to 45 lb-ft (61 Nm).
 - e. Torque the fan bolts to 8 lb-ft (11 Nm).

5. **If only the engine pulley has been removed and the belt is still around the alternator pulley:**
 - a. Unless the engine pulley and flywheel are apart, remove the four nuts in the face of the flywheel that secure the pulley coupling to the flywheel.
 - b. Pull the pulley and flywheel apart.
 - c. Wrap the belt around the engine pulley and lay the pulley around the crankshaft.
 - d. Make sure the key is in the crankshaft.
 - e. Line up the flywheel with the key and the four bolts in the pulley coupling.
 - f. Thread on the four coupling nuts, and the center bolt and washer.
 - g. Check to see that the belt is properly seated in its grooves in both pulleys.
 - h. Torque the coupling nuts to 5 lb-ft (6 Nm).
 - i. Torque the flywheel center bolt to 60 lb-ft (81 Nm).
6. **If both pulleys have been removed:**
 - a. Assemble the engine pulley and flywheel if they have been taken apart.
 - b. Wrap the belt around the engine pulley.
 - c. Install the flywheel.
 - d. Install the alternator pulley.
7. Reinstall the ignition coils.
8. Set the air gaps (see the Ignition Coils section) if the flywheel has been removed.
9. Install the fan shroud, making sure the exhaust manifold insulation ([Figure 30](#)) is in place. Note that the fan shroud bolts are of two lengths.
10. Torque the fan shroud bolts to 8 lb-ft (11 Nm).

8.2 Ignition System

The ignition system consists of the flywheel magnet and two ignition coil assemblies (magnetos) with integral spark plug cables and boots ([Figure 32](#)) and two spark plugs.

If the engine does not start:

1. Secure the spark plug cables on the spark plugs if they have come off.
2. Remove and examine the spark plugs and replace, if necessary. Check and reset the gap to 0.025 inch (0.6 mm).
3. Conduct the spark check.
4. Replace faulty ignition coil/cable assemblies and set the air gaps.

8.2.1 Spark Plugs

The spark plugs must be in good condition and have the proper gap for top engine performance.

To prevent cross threading, always thread a spark plug in by hand until it seats and then torque to 10 lb-ft (13 Nm) if new, or to 18 lb-ft (24 Nm) if being reused.

If the engine misses or performance otherwise deteriorates, remove and examine the spark plugs for signs of the following problems:

TABLE 8. SPARK PLUG PROBLEMS

Problem	Description
Light tan, gray or reddish deposits	Normal
One spark plug fouled	Broken spark plug cable, low cylinder compression
Soot fouled	Wrong spark plug heat range (too cold), duty cycle too short for engine to reach normal operating temperature
Fuel fouled	Wrong spark plug heat range (too cold), faulty choke operation, overly rich fuel mixture, dirty air filter
Oil fouled	Malfunctioning crankcase breather, worn rings, worn valve guides or seals
Burned or overheated	Leaking intake manifold gaskets, lean fuel mixture
Worn	Spark plug service life used up.

8.2.2 Spark Check

1. Remove the spark plugs.
2. Reconnect the spark plug cables.
3. Ground the side electrodes to bare metal on the engine.

WARNING

Gasoline and LPG are flammable and explosive and can cause severe personal injury or death. Make certain that no flammable fumes are present and that the area is well ventilated. Leave the generator set compartment door open for several minutes before performing this test.

4. Do not touch the spark plug or cable during testing. Crank the engine and look for the spark across each plug.
 - If the spark is weak or inconsistent across either plug, replace the plug with a new one.
 - If the spark still is weak or inconsistent, see [Section 8.2.3](#).

8.2.3 Ignition Coil (Magnetos) Service

Ignition Coil Resistance Test

1. If the spark is weak or inconsistent across either spark plug, check the ignition coil resistance between the steel core on the magneto and each spark plug cable terminal.
2. Replace an ignition coil assembly if its electrical resistance exceeds the maximum, as specified in the table below.

TABLE 9. IGNITION COIL RESISTANCES

Cylinder	Part Number	Dim "L"	Minimum (Ohms)*	Maximum (Ohms)*	Secondary Resistance (Ohms)	Typical Resistance (Ohms)
Left (No. 1)	0166-0859-01	800 +/- 12.7	13,700	33,000	13,700 to 33,000	19,000
Right (No. 2)	0166-0859-02	573 +/- 12.7	11,500	27,000	11,500 to 27,000	17,000

*Meter polarity is critical. Connect the positive (+) lead to ground.

Ignition Coil Removal

If the spark is weak or inconsistent across either spark plug and/or coil resistance is high or low, remove the ignition coil assembly as follows:

1. Remove the alternator/engine assembly from the generator set. See the Removing and Installing the Alternator/Engine Assembly section.
2. Remove the eight fan shroud bolts and remove the fan shroud. See [Figure 30](#).
3. Disconnect the ignition kill lead at the coil terminal.
4. Pull the spark plug cable through the grommet in the base.
5. Remove the two ignition coil mounting screws.

Ignition Coil Installation

Note in the figure below the location of the coil assembly that has the longer spark plug cable, which goes to cylinder No. 1 (left, or alternator side of engine).

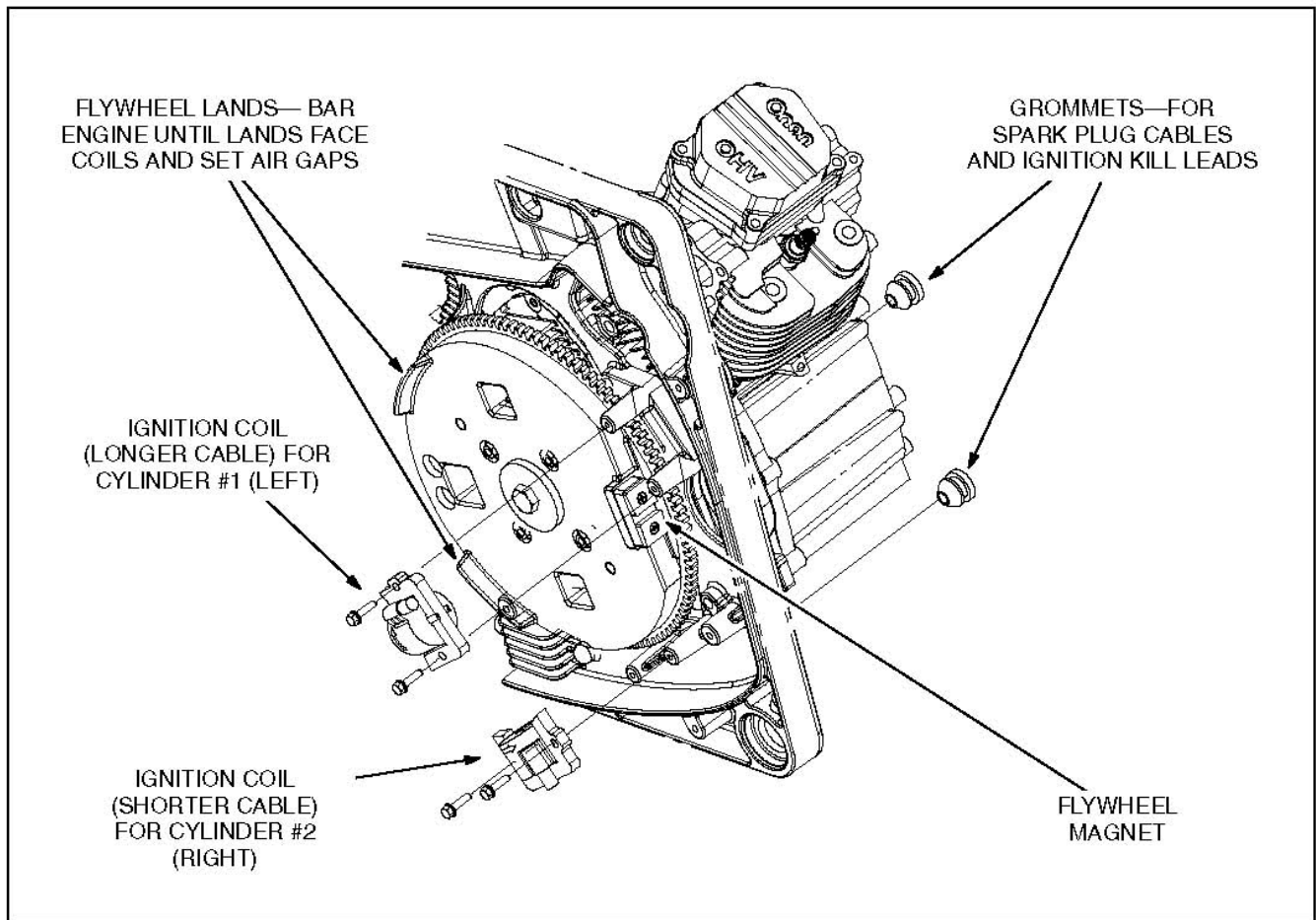

FIGURE 32. IGNITION COILS (MAGNETOS)

1. Perform the reverse of the removal steps, as shown above.
2. Set the air gaps as follows:
 - a. Bar the engine until the lands on the flywheel directly face the coils.
 - b. Place a 0.3 mm (0.012 in) thick feeler gauge between the coil and the land on the flywheel.
 - c. Hold the coil tight up against the feeler gauge and land.
 - d. Torque the two mounting bolts to 7 Nm (5 lb-ft).

8.3 Exhaust System

The generator set exhaust system must be gas-tight and prevent entry of exhaust gases into the vehicle interior.

⚠ WARNING

Exhaust Gas Is Deadly

Keep exhaust gases from entering the vehicle. Do not terminate the exhaust tail pipe underneath the vehicle or closer than 6 inches (153 mm) to openings into the vehicle. Route the exhaust system such that it is protected from damage (Figure 37, Figure 38 and Figure 39). Use approved materials only.

⚠ CAUTION

Unauthorized modifications or replacement of fuel, exhaust, air intake or speed control system components that affect engine emissions are prohibited by law in the State of California.

Failure to provide and maintain an approved spark arresting exhaust system can be a violation of the law. Liability for damage, injury and warranty expense due to the modification of the exhaust system or to use of unapproved parts is the responsibility of the person performing the modification or installing the unapproved parts. Contact a Cummins dealer for approved exhaust system parts.

8.3.1 Exhaust Manifold Removal

1. Remove the alternator/engine assembly from the generator set. See [Section 10.3](#).
2. Remove the eight fan shroud bolts and remove the fan shroud ([Figure 30](#)).
3. Remove the two flange bolts in each of the two exhaust outlet flanges and remove the manifold ([Figure 33](#)).

8.3.2 Exhaust Manifold Installation

Installation is the reverse of removal. Always install new flange gaskets when reinstalling the exhaust manifold and torque the flange nuts to 20 lb-ft (26 Nm).

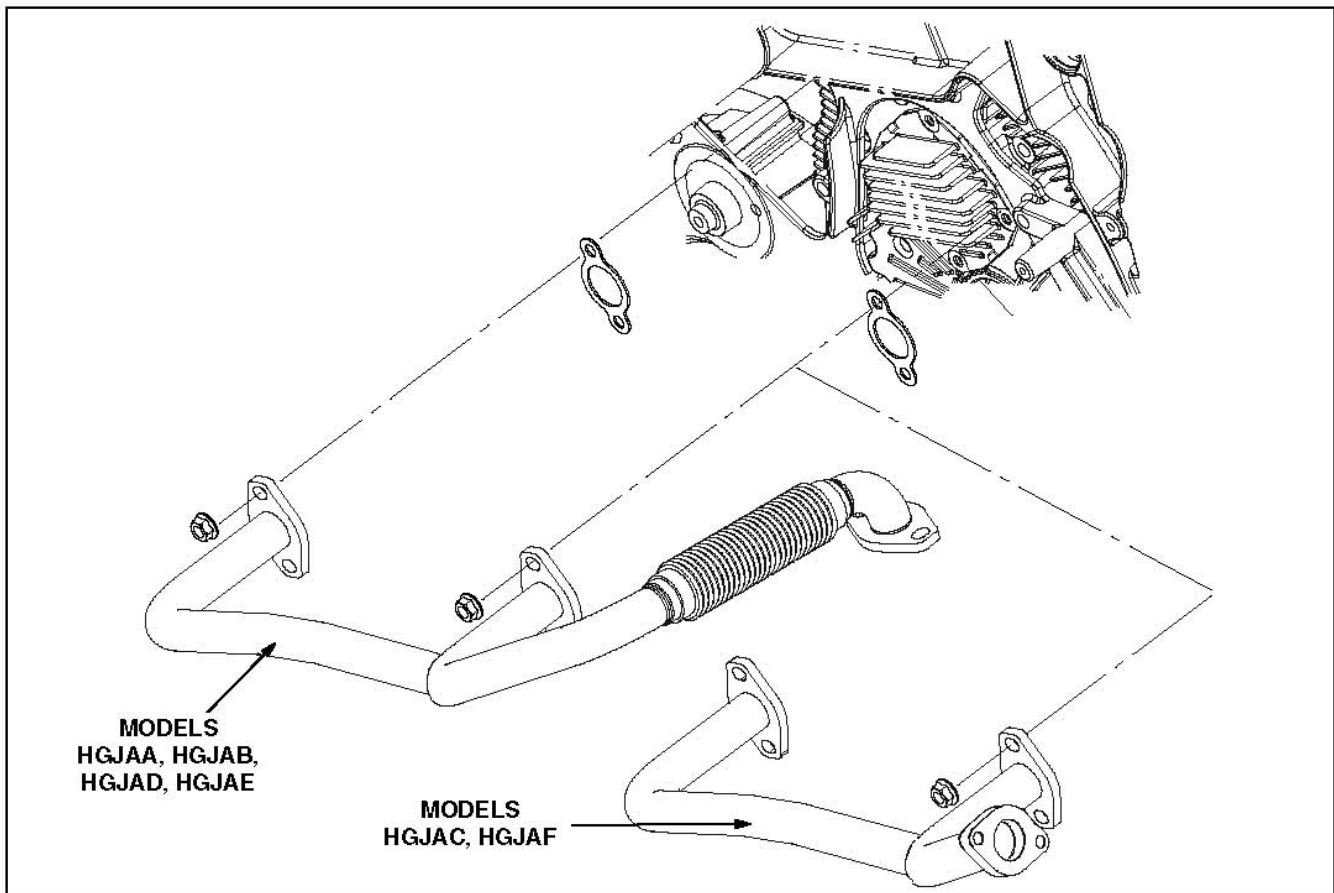

FIGURE 33. EXHAUST MANIFOLD

8.3.3 HGJAA, HGJAB, HGJAD, and HGJAE Model Mufflers

Always install new flange gaskets when reinstalling a muffler and torque the flange nuts to 10 lb-ft (13 N-m).

The muffler ([Figure 34](#)) is mounted inside the generator set enclosure. It is USDA-approved as a spark arresting muffler and meets RVIA EA-1 construction requirements. The HGJAB model muffler has the same inlet and outlet flange locations but has only one drum.

See [Section 8.3.5](#) regarding materials, clamps, support, routing and termination of the tailpipe.

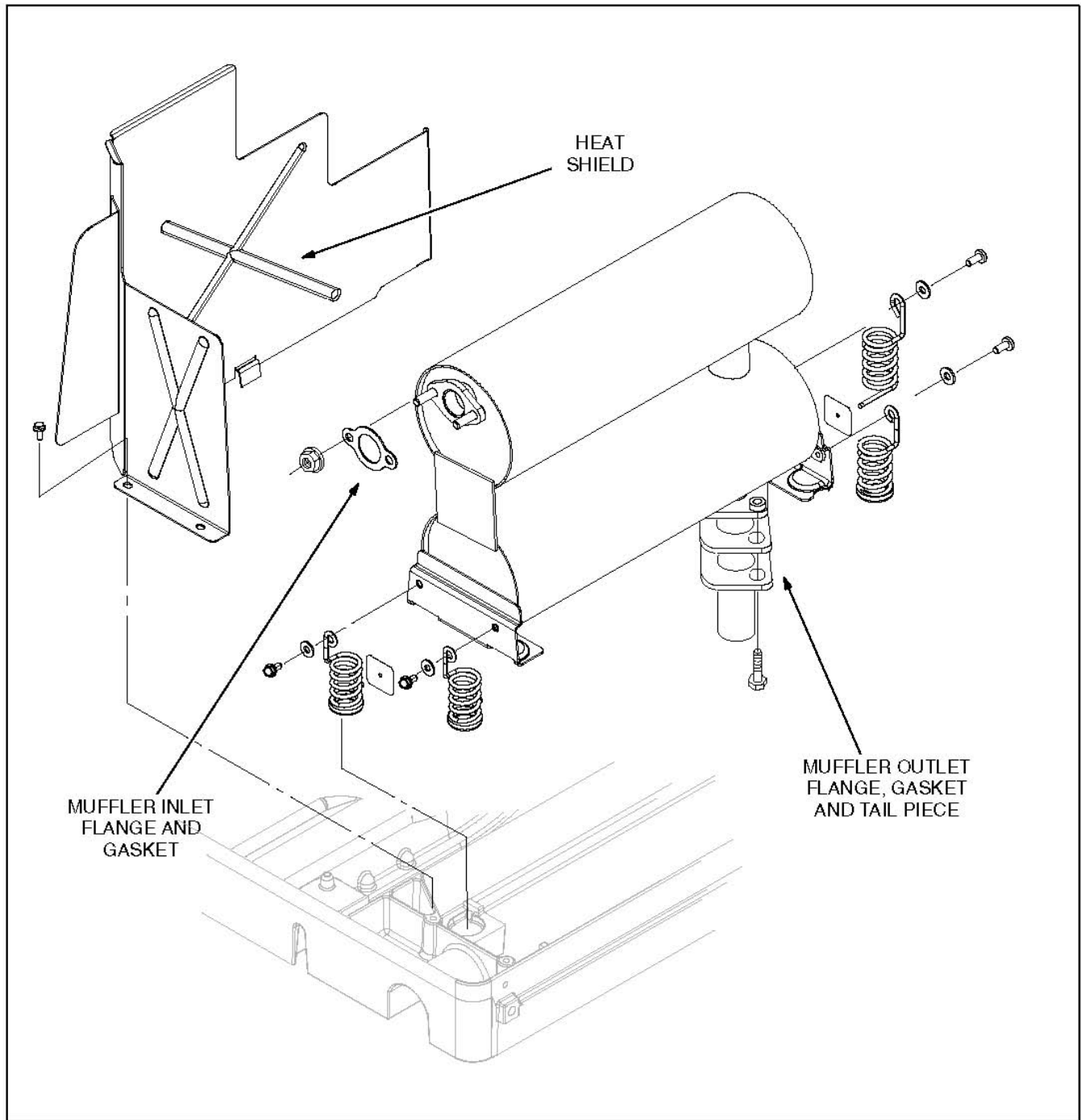

FIGURE 34. HGJAA, HGJAB, HGJAD, AND HGJAE MODEL MUFFLERS

8.3.4 HGJAC, HGJAF Mufflers

Always install new flange gaskets when reinstalling a muffler and torque the flange nuts to 10 lb-ft (13 N-m).

The muffler is side or bottom mounted and is provided in kit form with gasket and mounting hardware ([Figure 35](#)). The mufflers meet RVIA EA-1 construction requirements and the USDA approved spark arresting screen is for mounting on the end of the tail pipe. Follow the instructions in the kit when mounting a replacement muffler.

See Exhaust Tail Pipe in this section regarding materials, clamps, support, routing and termination of the tailpipe.

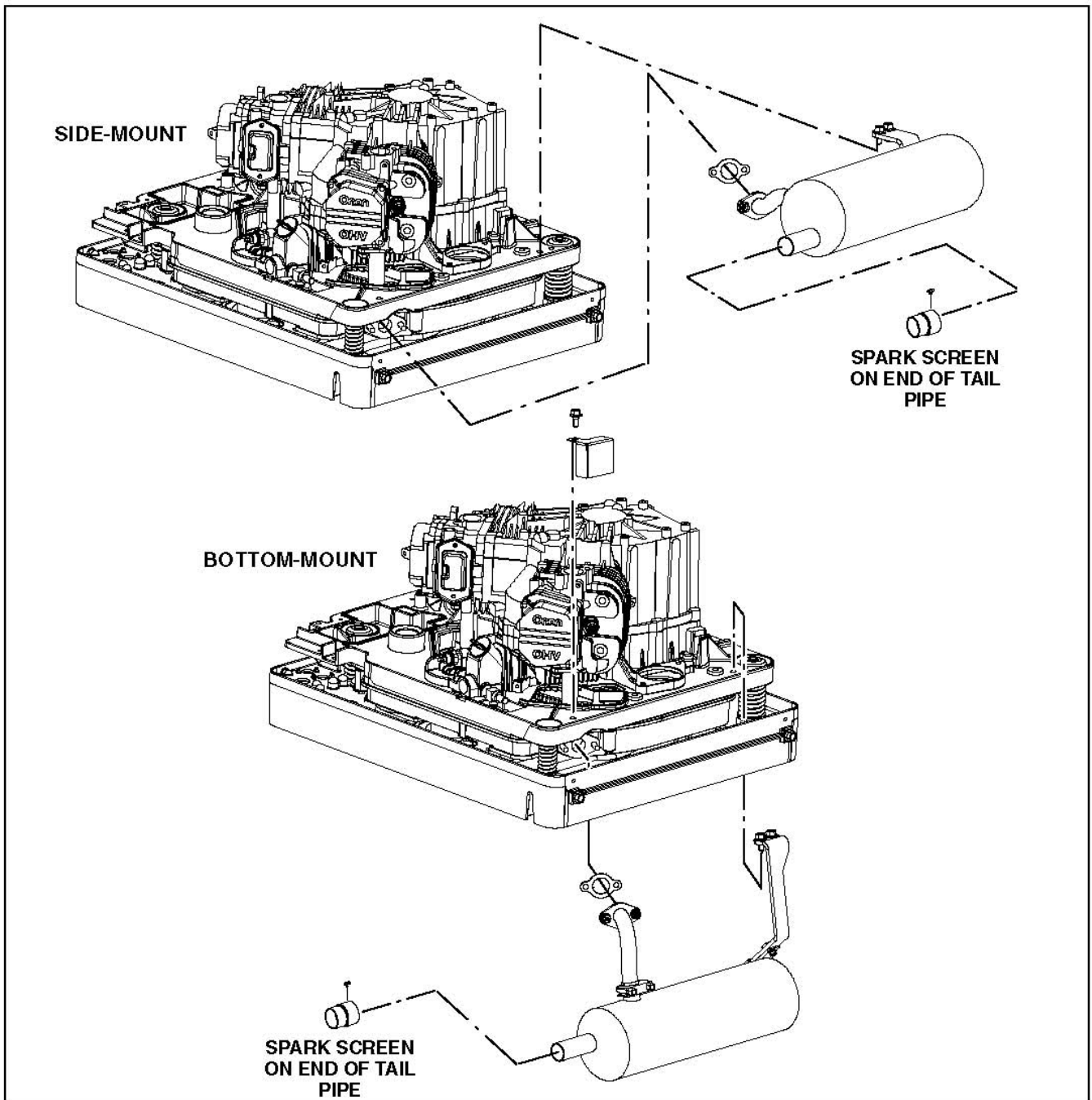

FIGURE 35. MODEL HGJAC, HGJAF MUFFLER

8.3.5 Exhaust Tail Pipe Installation

NOTICE

The exhaust tail pipe is customer-supplied.

- Clamp the tail pipe to the muffler outlet with a U-bolt muffler clamp (available from Cummins). Support a tail pipe longer than 1.5 ft (457 mm) near its end and at intervals of 3 ft (900 mm) or less. Use automotive-type tail pipe hangers (available from Cummins). Do not attach the hangers to combustible material such as wood.
 - Use 16-gauge 1-3/8 inch O. D. aluminized steel tubing or material of equivalent heat and corrosion resistance for the tail pipe. Do not use flexible pipe, which is neither gas tight nor durable.
 - Use U-bolt muffler clamps (available from Cummins) to connect sections of tail pipe. Overlapping pipe should be slotted. See the figure below.

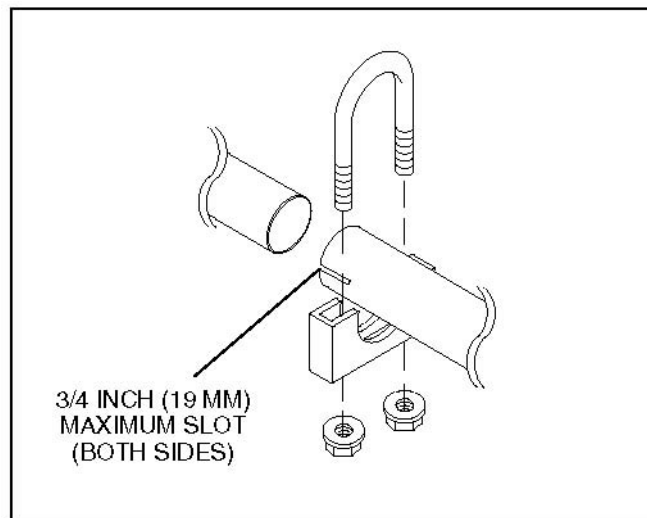

FIGURE 36. EXHAUST TAIL PIPE CONNECTIONS

- Do not route the tail pipe near fuel lines or fuel tanks.
- Do not route the tail pipe closer than 3 in (76 mm) to combustible material (wood, felt, cotton, organic fibers, etc.) unless it is shielded. The temperature rise (above ambient) on adjacent combustible material must not exceed 117 °F (65 °C).
- Do not route the exhaust tail pipe underneath the oil drain or air inlet such that it will restrict generator set cooling air.

⚠ WARNING

A hot exhaust tail pipe can ignite oil drain spills causing severe personal injury or death. Do not route the exhaust tail pipe underneath the oil drain.

- To keep the tail pipe from being damaged, do not route it such that it protrudes into the approach or departure angles of the vehicle or below the axle clearance line. See the figure below.

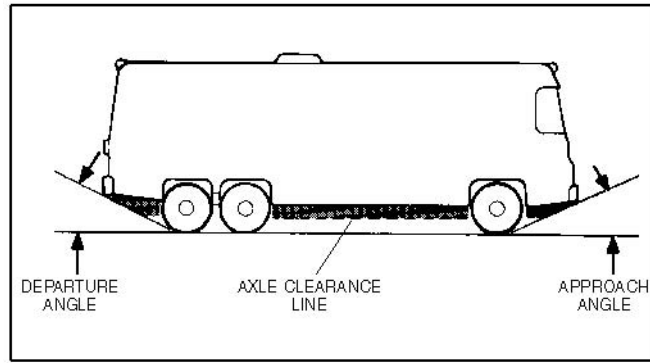

FIGURE 37. VEHICLE CLEARANCES

- Do not terminate the tail pipe underneath the vehicle. Extend it a minimum of 1 inch (25 mm) beyond the perimeter of the vehicle. See the figure below. Support the end of the tail pipe such that it cannot be pushed in and up under the skirt of the vehicle.

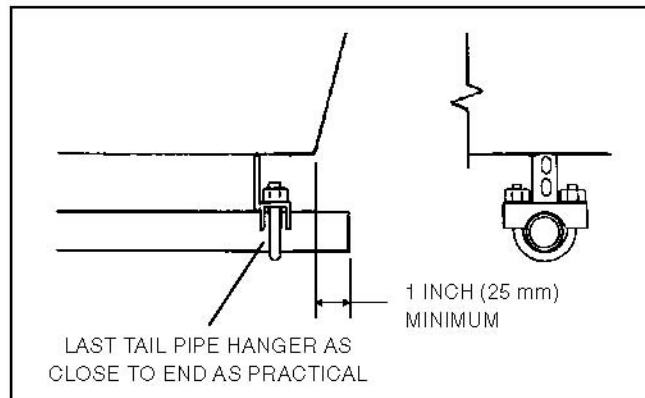

FIGURE 38. TERMINATING THE EXHAUST TAIL PIPE

- Do not interconnect the generator set and vehicle engine exhaust systems.

⚠ CAUTION

Interconnecting engine exhaust systems will lead to migration of exhaust condensate and soot into the idle engine, causing damage.

- Do not terminate the tail pipe such that it is closer than 6 in (153 mm) to any opening, such as a door, window, vent or unsealed compartment, into the vehicle interior. See the figure below.

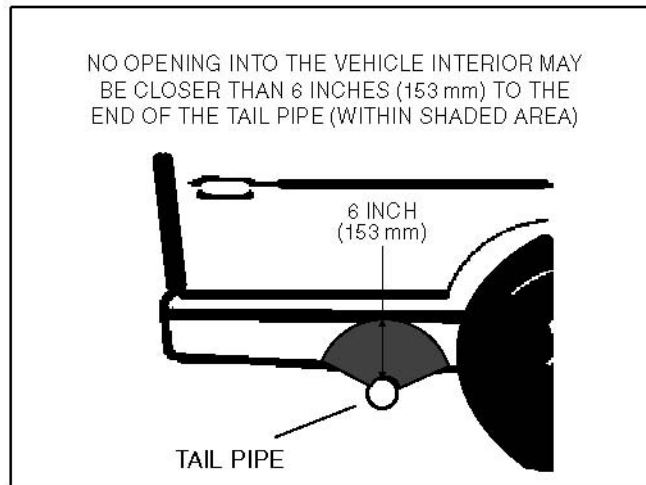

FIGURE 39. MINIMUM DISTANCES TO OPENINGS

- Make sure a tail pipe deflector will not cause excessive back pressure or interfere with removing the spark arresting screen.

⚠ CAUTION

Excessive back pressure can cause engine damage.

2. The spark arresting screen in the kit fits snugly on the end of 1-3/8 O. D. pipe. Push the spark arresting screen on to the end of the tailpipe all the way to the shoulder and secure it with a stainless steel sheet metal screw through the hole provided. See the figure below.

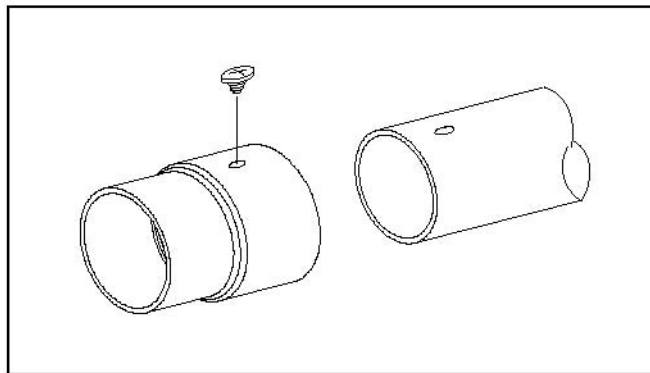

FIGURE 40. SPARK ARRESTING SCREEN

9 Fuel System

9.1 Gasoline Fuel System—HGJAA and HGJAD

See the operator manual for recommended fuels and the Specifications section for fuel consumption rates.

⚠ WARNING

Gasoline is flammable and explosive and can cause severe personal injury or death — Do not smoke — Keep flames, sparks, pilot lights, switches, arc-producing equipment and all other ignition sources away from fuel, fuel components and areas sharing ventilation — Keep an ABC fire extinguisher handy.

⚠ CAUTION

Unauthorized modifications or replacement of fuel, exhaust, air intake or speed control system components that affect engine emissions are prohibited by law in the State of California.

9.1.1 Operation

These generator set models are equipped with sequential multi-port fuel injection ([Figure 41](#)). A remote high-pressure fuel pump ([Figure 48](#)) supplies fuel to the generator set. The fuel pressure regulator adjusts fuel pressure based on engine intake manifold pressure. As engine load increases, fuel pressure will increase. In addition, the generator set:

- Monitors and governs AC output frequency (see the table below) as load varies by means of the throttle, which regulates the mass of air inducted each engine cycle.

TABLE 10. VOLTAGE/FREQUENCY/DROOP

Voltage			Frequency (Hz)	
Rated Voltage (60 Hz)	Max No Load	Min Full Load	No Load	Droop
120	125	115	60.5/59.5	N/A
240	250	230	60.5/59.5	N/A

- Monitors absolute intake Manifold Air Pressure (MAP) to determine engine load and modify the calculations of inducted air mass.
- Monitors Manifold Ambient Temperature (MAT) to modify the calculations of inducted air mass.
- Monitors the ignition pulses to determine fuel injector timing.
- Energizes the fuel injectors. Injector fuel delivery is proportional to pulse width, which the controller calculates on the basis of MAP and MAT to provide the desired air fuel ratio (AFR).
- Enriches AFR during cranking, warm-up and heavy load transients for good starting and performance.

9.1.2 Throttle Body Removal

The throttle body can be removed without removing the generator set enclosure. Referring to [Figure 41](#), remove the throttle body as follows:

1. Disconnect the fuel supply hose at the outlet of the fuel filter and the return fuel hose at the outlet to the fuel pressure regulator.
2. Disconnect the leads to the throttle body, MAP and MAT sensors and fuel injectors.
3. Remove the air filter cover and filter element and remove the two support screws in the back of the filter enclosure as well as the two throttle body mounting nuts.
4. Pull away the air filter enclosure and throttle body.
5. Avoid removing the throttle body through studs from the intake manifold. Otherwise, they will have to be replaced with new studs having factory-applied thread sealant.

9.1.3 Intake Manifold Removal

Remove the generator set enclosure and perform steps 1 through 3 of [Section 9.1.2](#). (Do not loosen the throttle body mounting nuts if the air filter, throttle body and manifold are to be removed as an assembly.) Then remove the intake manifold bolts and pull away the assembly.

9.1.4 Reassembly

Reassembly is the reverse of disassembly. Always use new gaskets when reassembling. Note the marking on the gasket between the air filter enclosure and the throttle body as to which way is up and which side is out.

1. Torque the intake manifold bolts to 19 lb-ft (26 Nm).
2. If a throttle body through stud came out, replace it with a new stud having factory-applied thread sealant. Clean the threads in the manifold of the old sealant. Torque the stud to 5.5 lb-ft (7 Nm).
3. Make sure the air intake fits through the opening in the base and that the engine breather tube is connected between the air filter enclosure and the cylinder head. To prevent damage to the air filter enclosure, first tighten the two (2) throttle body mounting nuts (left first) to 4.5 lb-ft (6 Nm), and then tighten the two (2) support screws.

See [Section 9.1.11](#) regarding proper hose clamps and crimping tools when reconnecting fuel hoses.

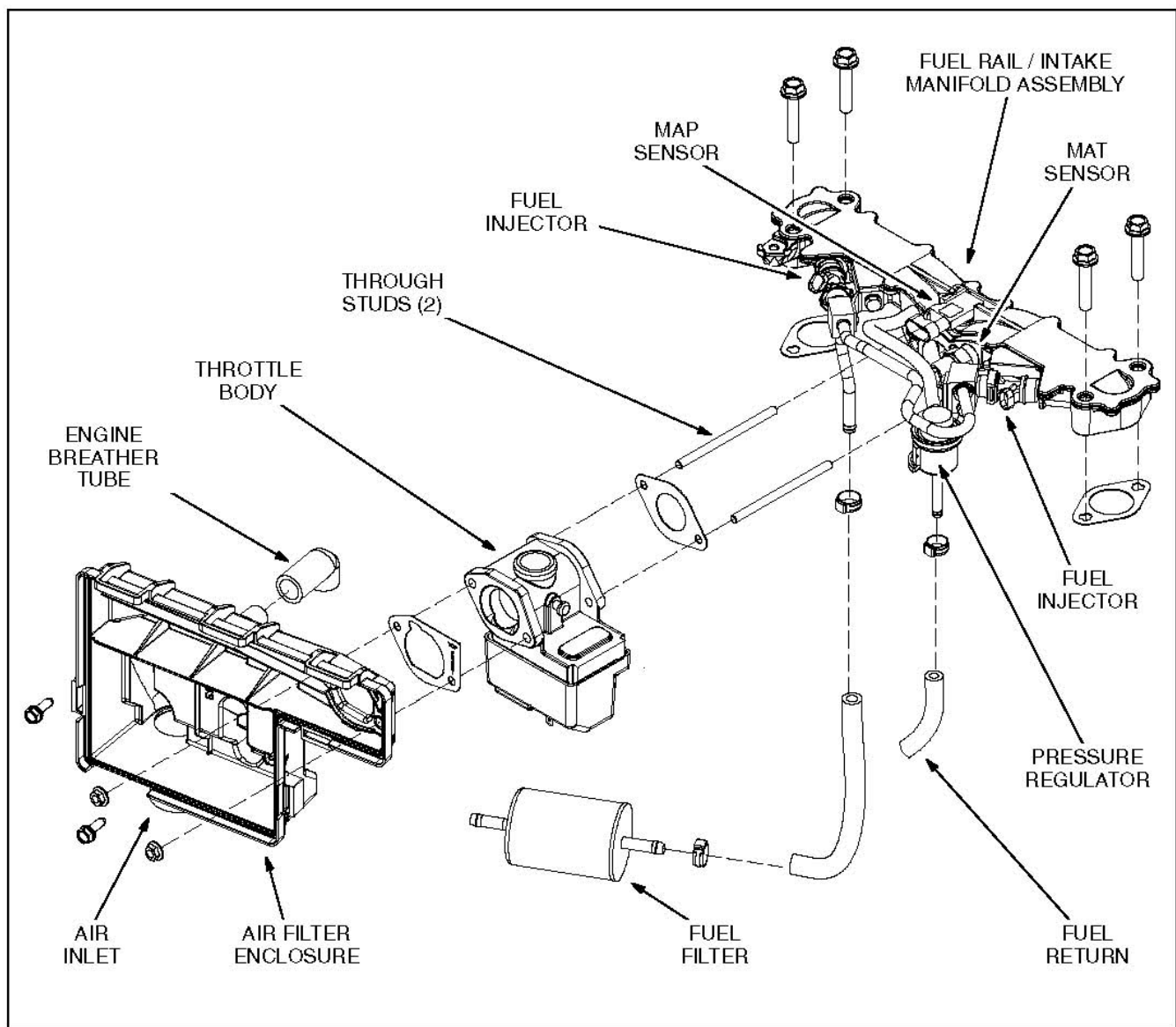

FIGURE 41. FUEL INJECTION SYSTEMS—SERIES HGJAA AND HGJAD

9.1.5 Fuel Rail and Injectors

The rail-injector-regulator assembly ([Figure 42](#)) is flexible enough to remove as an assembly from the intake manifold. All of the components shown except for the intake manifold and MAP sensor are removable without removing the generator set enclosure.

1. Thoroughly clean the outside of the assembly before disassembly. Be careful not to let dirt enter fuel system components while disassembled.
2. Remove the throttle body ([Figure 41](#)).
3. Disconnect the vacuum hose.
4. Remove the two mounting screws.
5. To pull an injector from the fuel rail, gently pry apart the two sides of the clip on the injector. Replace an injector if electrical resistance is not approximately 12.5 Ohms.

6. All joints have O-ring seals. When reassembling, apply light motor oil (sparingly) to the O-ring seals on the ends of the fuel injectors.
7. Push the injectors on by hand until they snap securely in place on the fuel rail.
8. Make sure the fuel rail brackets line up with and seat firmly against the machined bosses on the manifold.
9. Tighten the mounting screws to 75 lb-in (8.4 Nm).
10. Make sure to reconnect the vacuum hose. Push the ends on dry all the way up the hose barbs.

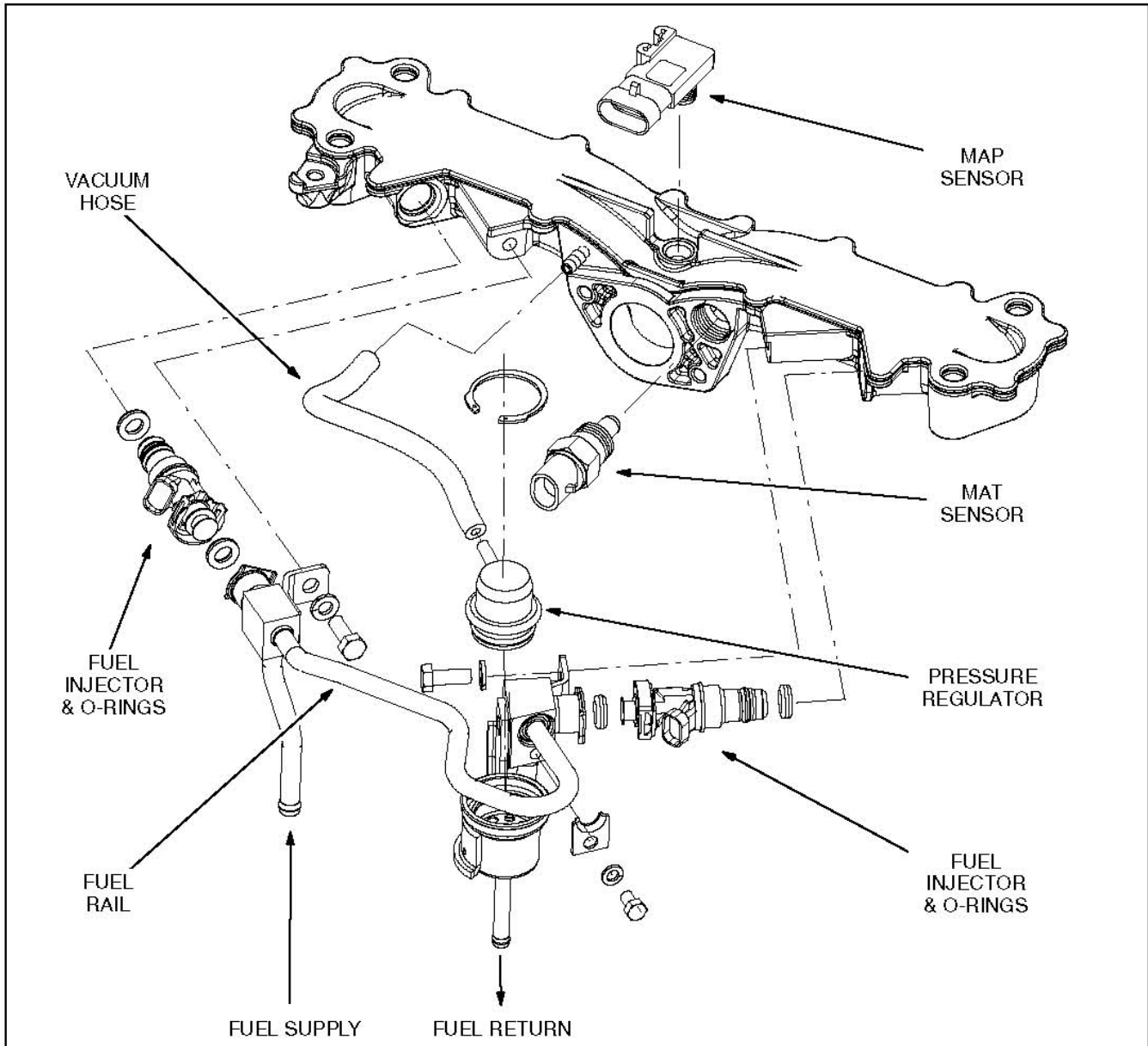

FIGURE 42. FUEL RAIL/INTAKE MANIFOLD ASSEMBLY

9.1.6 Fuel Pressure Regulator

The fuel pressure regulator body ([Figure 42](#)) is removable from the rail assembly by disconnecting the vacuum hose and removing the circlip.

Apply light motor oil (sparingly) to the two O-ring seals when reassembling.

The intake manifold vacuum hose is connected to the back of the regulator diaphragm to allow the fuel pressure regulator to regulate the fuel pressure based on engine intake manifold pressure. As engine load increases, fuel pressure will increase. Make sure to reconnect the vacuum hose. Push the ends on dry and all the way up the hose barbs.

NOTICE

When the vacuum line is removed from the fuel pressure regulator, there should be no gasoline present in the regulator or vacuum line.

9.1.7 MAT Sensor

Check electrical resistance across the two terminals of the MAT sensor ([Figure 42](#)). Replace the sensor if the resistance is not in [Table 11](#). To remove the sensor, remove the throttle body ([Section 9.1.2](#)), disconnect the wiring harness and unthread it from the manifold.

When reinstalling the sensor apply Teflon thread coating to the threads of the sensor. Turn it in until just two threads are left.

TABLE 11. MAT SENSOR RESISTIVE VALUES VS. TEMPERATURES

°F/°C	Resistive Value Minimum	Resistive Value Maximum
-22/-30	47924.1	58573
-13/-25	35157.6	42970
-4/-20	26045.1	31832
5/-15	19473.3	23800
14/-10	14688.9	17953
32/0	11171.7	13654
23/-5	8564.4	10467.6
41/5	6618.6	8089.4
50/10	5255.2	6300.8
59/15	4046.4	4945.6
68/20	3199.5	3910.5
77/25	2547	3113
86/30	2042	2494
95/35	1646	2010
104/40	1335	1631
113/45	1089	1331
122/50	893.3	1091.5
131/55	737	899.9
140/60	611.4	746.3

°F/°C	Resistive Value Minimum	Resistive Value Maximum
149/65	509.8	622.4
158/70	427.1	521.6
167/75	359.6	439.6
176/80	304.1	370.9
185/85	258.3	315
194/90	220.3	268.8
203/95	188.7	230.6
212/100	162.2	198.2

9.1.8 MAP Sensor

The generator set enclosure must be removed to remove the MAP sensor, which is pulled straight up to remove it from the intake manifold ([Figure 42](#)).

1. To check electrical resistances across pins A, B, and C (see the figure below). remove the connector.

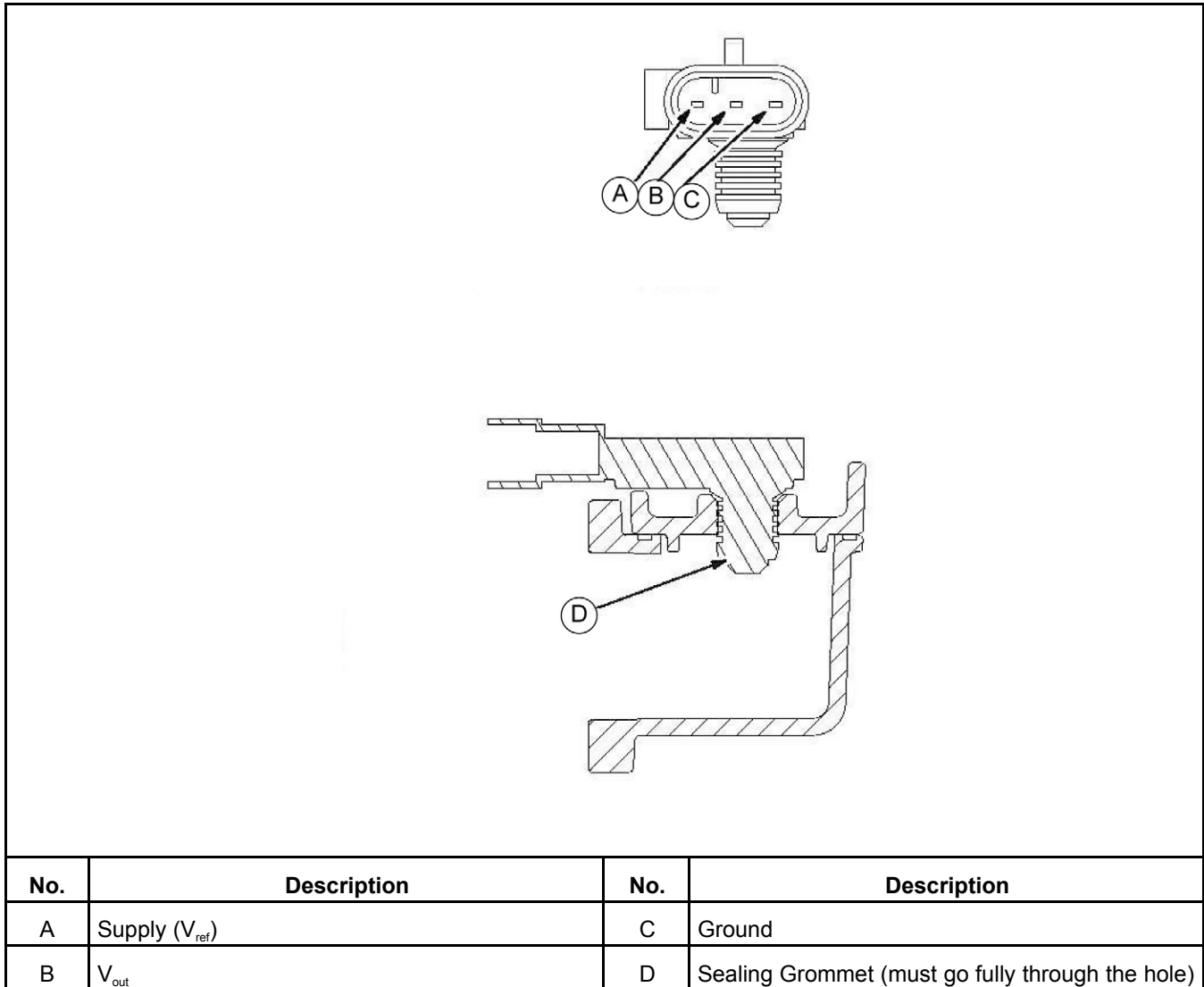

FIGURE 43. MAP SENSOR

- To determine the letter designation of a pin, check the marking on the corresponding connector lead. Replace the sensor if any reading is out of specification (see the table below).

TABLE 12. MAP SENSOR RESISTANCES AT ROOM TEMPERATURE AND PRESSURE

Sensor Type	Manufacturer Part Numbers	Pins	kΩ	Connection
Current	28074366	A-C	1.5 - 4.0 (Typical 2.2)	Supply (5 volts) to Ground
		A-B	6.0 - 8.5 (Typical 6.8)	Supply (5 volts) to V_{out}
		B-C	4.0 - 5.5 (Typical 4.6)	V_{out} to Ground
Legacy	16212460 and 28004403	A-C	4.0 - 4.2	Supply (5 volts) to Ground
		A-B	91 - 101	Supply (5 volts) to V_{out}
		B-C	91 - 97	V_{out} to Ground

NOTICE

Typically when the sensor fails, one or more of the resistance values listed above will be drastically out of specification.

3. When reinstalling the sensor, apply light motor oil (sparingly) to the sealing grommet and push it in by hand. Make sure the grommet is all the way through the hole so that it will not come out ([Figure 43](#)).

9.1.9 Throttle Body/Governor Actuator

The throttle body and governor actuator are one assembly (see the figures below). The throttle plate is mounted on the same ball bearing-mounted shaft as the actuator rotor. The actuator stator is energized by a pulse width modulated signal from the generator set controller, which monitors frequency and recalculates the pulse width, (and therefore the throttle position), which is necessary to maintain rated frequency as load varies. The torsion spring opposes the rotor.

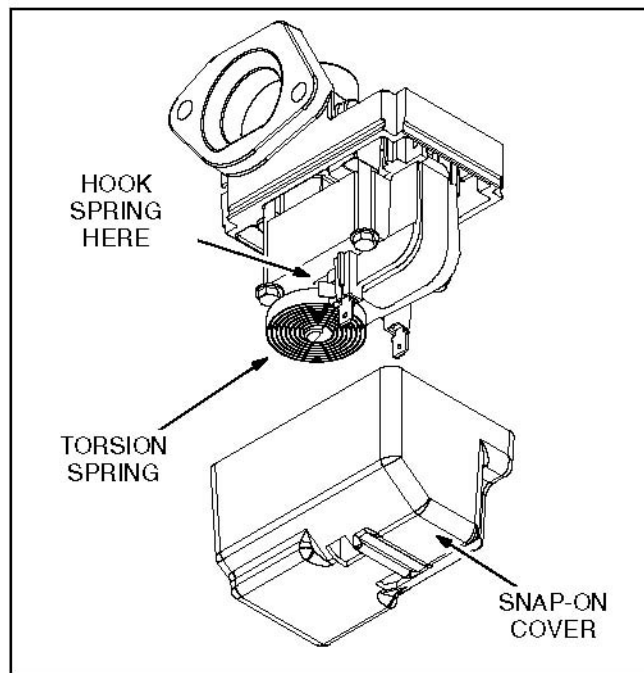

FIGURE 44. THROTTLE BODY/GOVERNOR ACTUATOR

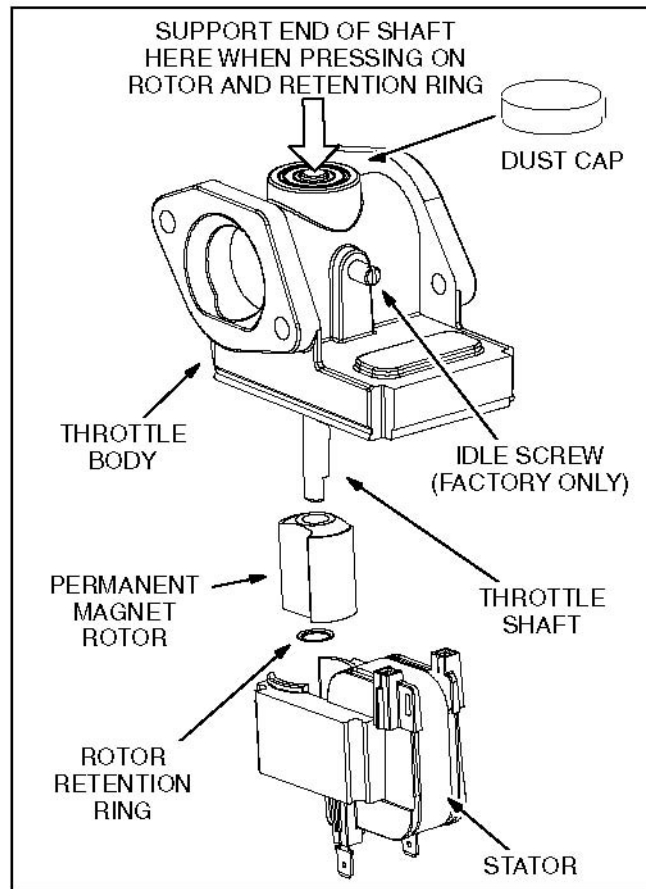

FIGURE 45. ACTUATOR ROTOR AND STATOR

NOTICE

Do not attempt to re-adjust the idle screw (Figure 45), which was set and sealed at the factory.

• **Checking Throttle Plate Action:**

If the generator set does not start, remove the air filter and observe the throttle plate while cranking. The throttle plate should close against the idle stop when de-energized, open fully while cranking, and modulate smoothly while running.

- If the throttle does not function, connect its terminals to a 12 V battery with jumpers.
- If the throttle opens fully, the problem is probably in the control circuit, not the throttle body.

• **Checking Stator Winding Continuity:**

1. If the throttle does not open, disconnect the wiring at the stator terminals, and check for electrical resistance.
2. Replace the stator if it is not between 4.5 and 5.5 Ohms.

• **Replacing the Stator:**

1. To remove the stator assembly from the throttle body, remove the snap-on cover, torsion spring and the four mounting screws.
2. When reassembling, make sure that the mating bosses are properly aligned before tightening the four stator screws. Torque the four stator screws to 18 lb-in (2 Nm).

3. Press the torsion spring onto the flat on the end of the throttle shaft and catch the spring hook in the slot in the coil bobbin ([Figure 44](#)).

- **Replacing the Throttle Body:**

1. Replace the throttle body if there is any looseness, play, or binding in the throttle shaft, or if the factory seal on the idle screw has been broken. When pressing the rotor and retention ring onto the shaft of the throttle body, support the end of the shaft as shown ([Figure 45](#)) to avoid damage to the bearings and throttle plate.
2. Assemble the stator, torsion spring, snap-on cover, and dust cap to the body.

9.1.10 Remote Fuel Pump

[Figure 48](#) illustrates the remote fuel pump kit for Model HGJAA. The Model HGJAD kits include fill neck adaptors for fuel supply and return connections at the tank and are specific to each make and model of vehicle. The right kit must be used. Follow the instructions in the kit when replacing a pump assembly. [Figure 46](#) illustrates the 2-pin remote pump wiring connector and in-line fuse and [Figure 47](#) the fuel supply and return fittings at the generator set.

WARNING

Gasoline is flammable and explosive and can cause severe personal injury or death.

- ***Do not smoke.***

Keep flames, sparks, pilot lights, switches, arc-producing equipment, and all other ignition sources away from fuel, fuel components, and areas sharing ventilation.

- ***Keep an ABC fire extinguisher handy.***

Fuel Pressure: Fuel pressure as measured between the fuel rail and the high pressure fuel pump with the generator set off and priming the fuel pump should be approximately 45 psi.

- A much higher fuel pressure indicates a restriction in the return fuel system.
- A much lower fuel pressure indicates a faulty fuel pump, plugged fuel filter or restriction in the supply fuel system.

Fuel Pump Flow Test:

1. Disconnect the fuel return line at a convenient point between the generator set and supply tank and be prepared to collect the fuel in a gallon container.
2. Prime the generator set for exactly one (1) minute taking care not to spill any fuel. The whole fuel system, exclusive of the injectors, is probably in good working order if fuel flow is approximately 1 quart (0.9 liter) per minute and fuel pressure is approximately 45 psi. A much higher fuel pressure indicates a blockage in the fuel system.
3. Make sure to reconnect the fuel return line.

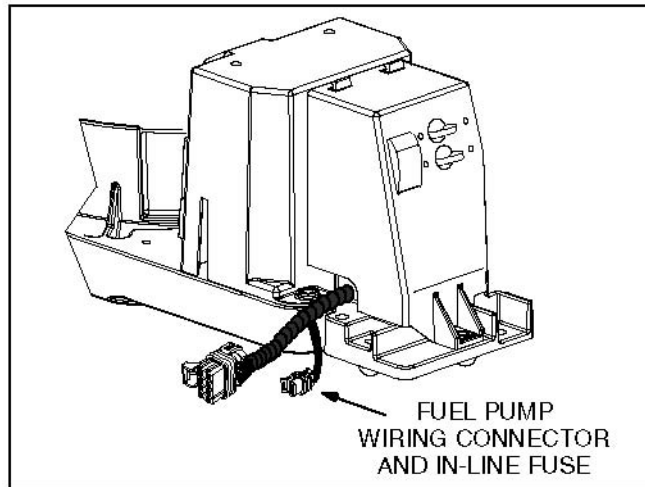

FIGURE 46. FUEL PUMP WIRING CONNECTOR

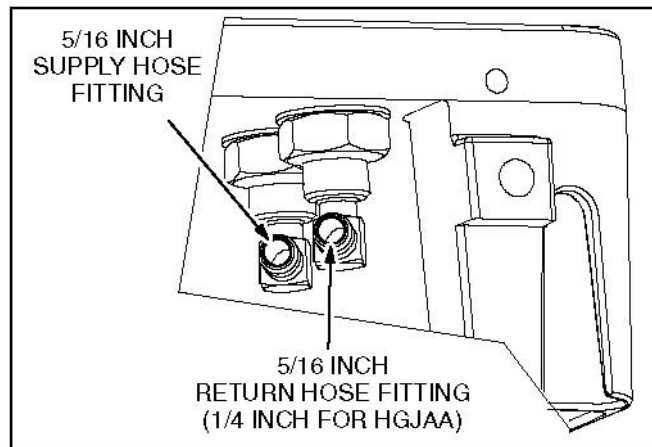

FIGURE 47. FUEL FITTINGS

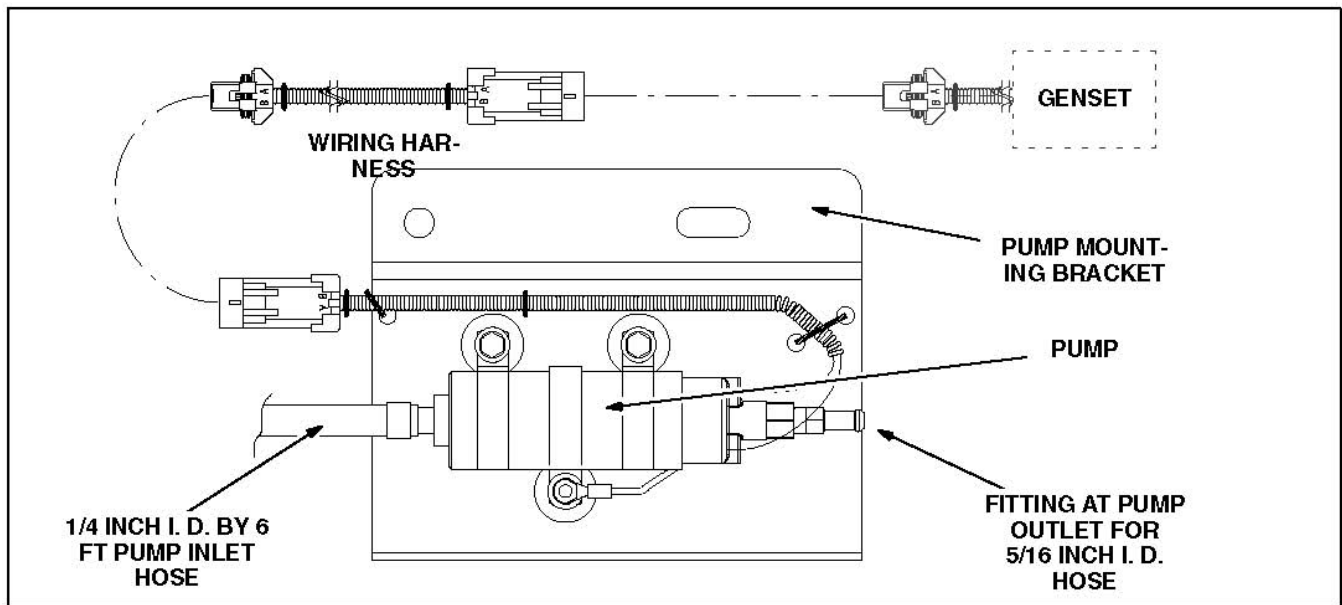

FIGURE 48. REMOTE FUEL PUMP—HGJAA

9.1.11 Fuel Connections

⚠ WARNING

Electric arcs can ignite gasoline leading to severe personal injury or death. Do not run wiring and fuel lines together.

⚠ CAUTION

When connecting fuel hoses, only use soap-free lubricants such as WD40, which runs through fuel without leaving residues that can clog fuel jets.

A fuel return line to the supply tank must be provided.

Generator set and propulsion engine fuel supply and return lines must not be interconnected.

The maximum fuel pump lift is 36 in (914 mm).

The generator fuel pickup should be terminated higher in the supply tank than the propulsion engine pickup to keep from running the vehicle out of fuel.

Do not change or remove the fuel fill tube, fill limiter vent, vapor canister, vapor lines, filler cap or any other part of the fuel system without the express approval of the vehicle chassis manufacturer. Modifications must conform with applicable sections of the Code of Federal Regulations, Title 49, and other standards.

NOTICE

Support fuel lines to restrain movement and prevent chaffing or contact with sharp edges, electrical wiring and hot exhaust parts.

- **Fuel Line Materials for Model HGJAA:** Use the following materials for the supply line between the tank and pump and for the return line between generator and tank.
 - *Tubing:* Use 1/4 in O. D. (± 0.003 in) welded and drawn Type 304L stainless or AISI 1008-1010 low carbon steel tubing of 0.028 in minimum wall thickness. The tubing must meet requirements for 150 psi operating pressure (Ref. ASTM A 539-99) and have corrosion resistance equal to or better than hot-dipped zinc galvanization.
 - *Hose Beads:* Use suitable tooling to form tubing ends into SAE J1231 Type 1 or Type 3 double-flare hose beads—*recommended* for all tubing and fittings for fuel return.
 - *Flexible Hose:* Use 1/4 in I. D. SAE J30R7 hose or better.
 - *Hose Clamps:* Use stainless steel stepless ear clamps. Cummins P/N 0503-1951-08, Oetiker P/N 16700008 or equivalent are *recommended*.
- **Fuel Line Materials for Model HGJAD:** Use the same materials for the line between the pump and generator as for model HGJAA. Replace fuel hose clamps, hose and tubing as necessary with the following materials. Good connections are required to prevent fuel leakage under pump pressure.
 - *Tubing:* Use 5/16 in O. D. (± 0.003 in) welded and drawn Type 304L stainless or AISI 1008-1010 low carbon steel tubing of 0.028 in minimum wall thickness. The tubing must meet requirements for 150 psi operating pressure (Ref. ASTM A 539-99) and have corrosion resistance equal to or better than hot-dipped zinc galvanization.
 - *Hose Beads:* Use suitable tooling to form tubing ends into SAE J1231 Type 1 or Type 3 double-flare hose beads, which are **required** for all tubing and fittings.
 - *Flexible Hose:* Use 5/16 in I. D. SAE J30R9 hose.
 - *Hose Clamps:* Use stainless steel stepless ear clamps. Cummins P/N 0503-1951-13, Oetiker P/N 16700013 or equivalent are **required**.
- **Fuel Line Routing:** If it is necessary to replace fuel lines, route the supply and return lines side-by-side along bulkheads and frame members such that they are protected, and at or above the top of the fuel tank to reduce siphoning if a line breaks or a hose comes off. The entire length of a fuel line must be visible for inspection and accessible for replacement.

9.2 Gasoline Fuel System—HGJAB and HGJAE

See the operator manual for recommended fuels and the Specifications section for fuel consumption rates.

WARNING

Gasoline is flammable and explosive and can cause severe personal injury or death — Do not smoke — Keep flames, sparks, pilot lights, switches, arc-producing equipment and all other ignition sources away from fuel, fuel components and areas sharing ventilation — Keep an ABC fire extinguisher handy.

CAUTION

Unauthorized modifications or replacement of fuel, exhaust, air intake or speed control system components that affect engine emissions are prohibited by law in the State of California.

9.2.1 Operation

Gasoline and combustion air are mixed in the proper ratio in the carburetor ([Figure 49](#)) for good starting and good performance over the entire load range. The mechanical governor ([Section 9.4.3](#)) operates the throttle in the carburetor to maintain constant engine speed (within a range of 5 percent) as load varies.

9.2.2 Removing Carburetor

The carburetor can be removed without removing the generator set enclosure. Referring to [Figure 49](#), remove the carburetor as follows:

1. Disconnect the fuel hose at the carburetor.
2. Disconnect the governor linkage ([Section 9.4](#)).
3. Disconnect the leads to the choke heater and fuel cutoff valve ([Figure 50](#)).
4. Remove the air filter cover and filter element and remove the two support screws in the back of the filter enclosure as well as the two carburetor mounting nuts.
5. Pull away the air filter enclosure and carburetor. Drain as much of the fuel in the float bowl by turning the carburetor upside down over a waste fuel container.
6. Avoid removing the carburetor through studs from the intake manifold. Otherwise, they will have to be replaced with new studs having factory-applied thread sealant.

9.2.3 Removing Intake Manifold

Remove the genset enclosure and perform step 1 through step 4 of [Section 9.2.2](#). (Do not loosen the carburetor mounting nuts if the air filter, carburetor and manifold are to be removed as an assembly.) Then remove the intake manifold bolts and pull away the assembly.

9.2.4 Reassembly

Reassembly is the reverse of disassembly. Always use new gaskets when reassembling. Note the marking on the gasket between the air filter enclosure and the carburetor as to which way is up and which side is out.

Torque the intake manifold bolts to 19 lb-ft (26 N-m).

If a carburetor through stud came out, replace it with a new stud having factory-applied thread sealant. Clean the threads in the manifold of the old sealant. Torque the stud to 5.5 lb-ft (7 N-m).

Make sure the air intake fits through the opening in the base and that the engine breather tube is connected between the air filter enclosure and the cylinder head. To prevent damage to the air filter enclosure, first tighten the two (2) carburetor mounting nuts (left first) to 4.5 lb-ft (6 N-m) and then tighten the two (2) support screws.

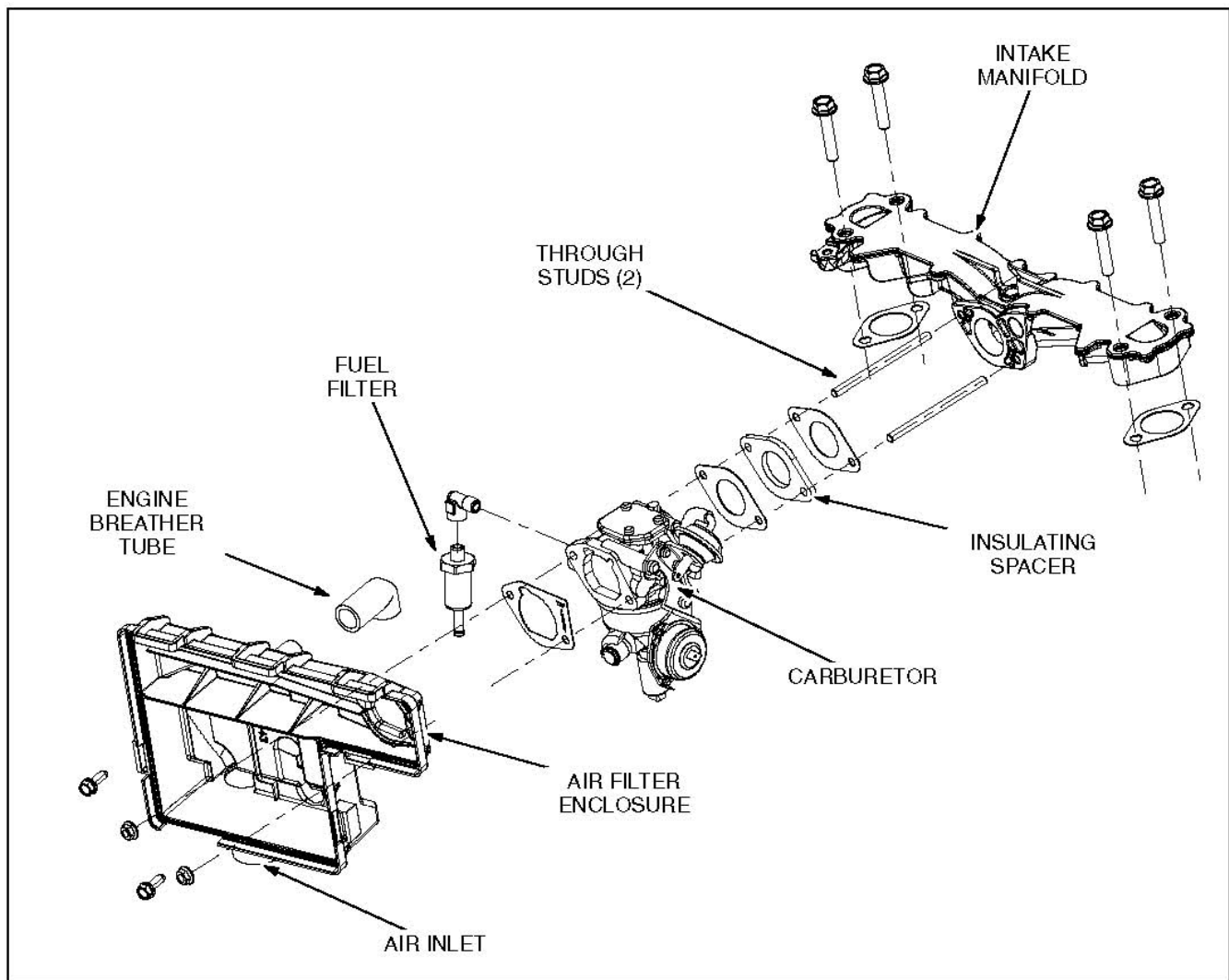

FIGURE 49. GASOLINE CARBURETOR AND INTAKE MANIFOLD ASSEMBLY

9.2.5 Carburetor

The carburetor ([Figure 50](#)) is not likely to cause problems and should be replaced only after all other problems have been eliminated (see the Troubleshooting section). The carburetor fuel mixture adjustments are sealed at the factory. See [Section 9.4.3](#) to connect the throttle link and to adjust the idle (throttle) stop screw.

9.2.6 Automatic Choke

The automatic choke is operated by a bi-metal/heater assembly and a vacuum breaker assembly ([Figure 50](#)). Conduct the following checks and adjustments before replacing a carburetor/choke assembly:

1. Apply 12 VDC across the heater terminals. The choke should open fully in 2 to 3 minutes.
2. Check the heater alignment marks and realign if out of alignment. The choke should be closed at temperatures below 70° F (21° C). It may be partly open above 70° F (21° C), but should close almost completely when vibrated (engine cranked).

- The vacuum breaker diaphragm must not leak under a vacuum of 30 inches Hg (100 kPa). It should not take a vacuum greater than 2.4 inches Hg (8 kPa) to open the choke fully. At a vacuum of 1 inch Hg (3.2 kPa) the choke plate should be at the angle shown ([Figure 50](#)). If necessary, bend the link at the point shown, using two pliers.

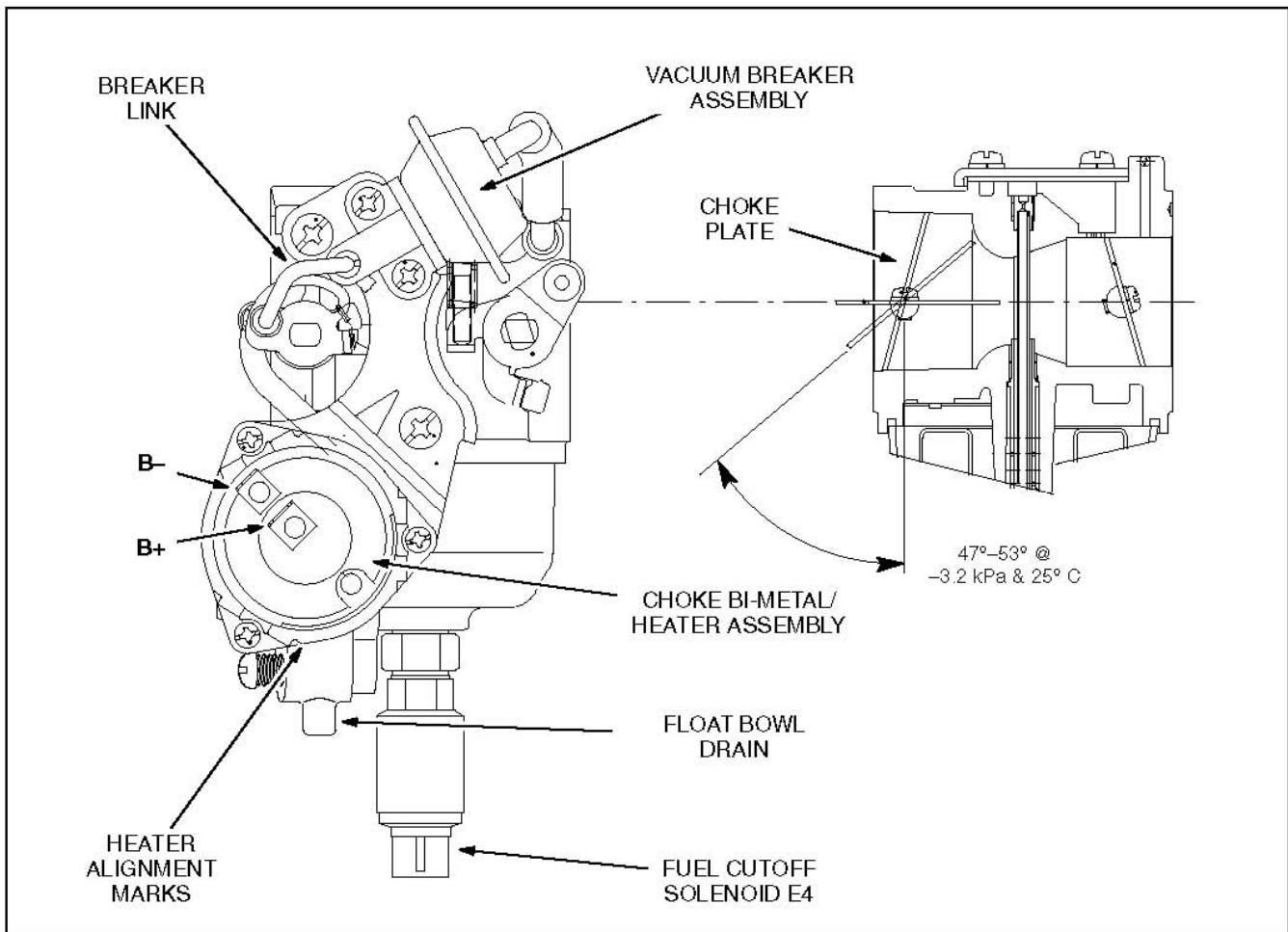

FIGURE 50. CARBURETOR / CHOKE ASSEMBLY

9.2.7 Fuel Cutoff Solenoid E4

The fuel cutoff solenoid is threaded into the bottom of the carburetor float bowl ([Figure 50](#)). If the engine does not start because it is not getting fuel, but fuel can be drained from the carburetor float bowl, the solenoid probably is not opening and should be replaced. To remove and replace the cutoff solenoid:

- Remove the carburetor.
- Using a 15 mm wrench on the float bowl adapter (brass) and a 13 mm wrench on the solenoid, remove and discard the solenoid and aluminum washer.
- When installing the new solenoid, use a new washer and torque it to 8 lb-ft (10 Nm). Make sure the float bowl adapter does not turn.
- Reassemble all the parts that were removed.

9.2.8 Fuel Filters

One fuel filter is provided at the fuel pump inlet fitting ([Figure 49](#)). Replace the filter at the interval recommended in the Operator's Manual, or sooner if performance indicates that the filter is clogged. Use an 11/16-inch deep socket to remove the filter. Thread a replacement filter on by hand and then 1 to 1-1/2 turns more.

9.2.9 Fuel Pump

An electric fuel pump ([Figure 51](#)) supplies fuel to the carburetor. Test the pump as follows if the generator set does not start, starves for fuel or floods with fuel:

1. Check the fuel tank and fill as necessary.
2. Disconnect the fuel hose at the carburetor and connect a fuel pressure gauge accurate enough to read in the 2.5 to 4 psi (17 to 27 kPa) range.
3. Prime the fuel system by holding the control switch at Stop/Prime, while observing the gauge. The pressure should hold constant between 2.5 to 4 psi (17 to 27 kPa), or drop off very slowly.
4. If there is no pressure, tap the pump body with a screw driver handle to free the piston from fuel the deposits.
5. If there is no response, replace it with a Cummins-supplied pump.

⚠ WARNING

Do not substitute an automotive electric fuel pump for the Cummins-supplied fuel pump. The output pressure from an automotive pump is much higher and can cause carburetor flooding or fuel leakage, creating a fire hazard.

6. If the pressure is above or below the 2.5 to 4 psi (17 to 27 kPa) range, check the fuel pressure at the inlet to the pump, with and without the vehicle propulsion engine running. Pressure higher than 4 psi (27.5 kPa) can cause flooding past the needle and float assembly in the carburetor. A lift of more than 3 ft (-1.3 psi) will prevent the pump from delivering enough fuel. Reinstall the fuel line, as necessary, if the inlet pressure does not fall in the -1.3 to 1.5 psi range.

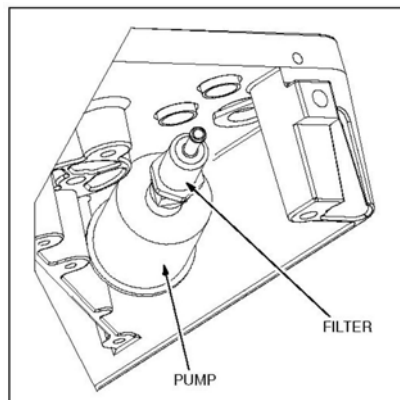

FIGURE 51. FUEL PUMP AND FILTER

9.2.10 Fuel Connections

⚠ WARNING

Excessive fuel pressure can flood the generator set causing a fire. The generator set fuel supply line pressure must not exceed 1-1/2 psi under any condition.

⚠ CAUTION

When connecting fuel hoses, only use soap-free lubricants such as WD40, which runs through fuel without leaving residues that can clog fuel jets.

Cummins recommends a separate fuel pickup tube or a separate fuel tank for the generator set. The generator set must never be connected to the **fuel supply line** of the vehicle engine, either to a high-pressure system (pump in tank), which can overpressurize the generator set fuel system, or to a vacuum system (pump on engine), which can cause the generator set to starve for fuel. Some vehicle chassis manufacturers allow connections to the **fuel return line** on high pressure fuel systems. Contact the vehicle chassis manufacturer for approval. Fuel line pressure at the point where the generator set is connected must not exceed 1-1/2 psi under any condition.

The maximum fuel pump lift is 36 in (914 mm).

The generator set fuel pickup should be terminated higher in the supply tank than the propulsion engine pickup to keep from running the vehicle out of fuel.

Do not change or remove the fuel fill tube, fill limiter vent, vapor canister, vapor lines, filler cap or any other part of the fuel system without the express approval of the vehicle chassis manufacturer. Modifications must conform with applicable sections of the Code of Federal Regulations, Title 49, and other standards.

NOTICE

Support fuel lines to restrain movement and prevent chaffing or contact with sharp edges, electrical wiring and hot exhaust parts.

- **Fuel Line Materials:** Replace fuel hose clamps, hose and tubing as necessary with the following materials. Good connections are required to prevent fuel leakage.

⚠ WARNING

Electric arcs can ignite gasoline leading to severe personal injury or death. Do not run wiring and fuel lines together.

- **Tubing:** Use 1/4 inch O. D. (± 0.003 inch) welded and drawn Type 304L stainless or AISI 1008-1010 low carbon steel tubing of 0.028 inch minimum wall thickness. The tubing must meet requirements for 150 psi operating pressure (Ref. ASTM A 539-99) and have corrosion resistance equal to or better than hot-dipped zinc galvanization.
 - **Hose Beads:** Use suitable tooling to form tubing ends into SAE J1231 Type 1 or Type 3 double-flare hose beads, which are recommended for all tubing and fittings for fuel return.
 - **Flexible Hose:** Use 1/4 in I. D. SAE J30R7 or hose or better.
 - **Hose Clamps:** Use stainless steel stepless ear clamps. Cummins P/N 0503-1951-11, Oetiker P/N 16700011 or equivalent are *recommended*.
- **Fuel Line Routing:** If it is necessary to replace the fuel line, route the fuel line along bulkheads and frame members such that they are protected, and at or above the top of the fuel tank to reduce siphoning if a line breaks or a hose comes off. The entire length of a fuel line must be visible for inspection and accessible for replacement.

9.3 LPG Fuel System—HGJAB and HGJAE

⚠ WARNING

LPG is flammable and explosive and can cause severe personal injury or death.

- *Do not smoke.*
- *Keep flames, sparks, pilot lights, switches, arc-producing equipment and all other ignition sources away from fuel, fuel components and areas sharing ventilation.*
- *Keep an ABC fire extinguisher handy.*

⚠ WARNING

NFPA 58, Section 1.6 requires all persons handling LPG to be trained in proper handling and operating procedures.

⚠ CAUTION

Unauthorized modifications or replacement of fuel, exhaust, air intake or speed control system components that affect engine emissions are prohibited by law in the State of California.

Before servicing a Low-Pressure (Vapor Withdrawal) LPG fuel system, check to see that the LPG container is at least half full. The problem may be that there is not enough LPG to provide the rate of vaporization necessary to meet generator set demand, especially on cold days and/or when the generator set is under full load.

9.3.1 Operation

LPG and combustion air are mixed in the proper ratio in the mixer ([Figure 52](#)) for good starting and good performance over the entire load range. The demand regulator on Low-Pressure LPG Models ([Figure 53](#)) or the converter on High-Pressure LPG Models ([Figure 55](#)) meters LPG to the mixer in proportion to venturi vacuum. The mechanical governor ([Section 9.4.3](#)) operates the throttle in the mixer to maintain constant engine speed (within a range of 5 %) as load varies.

9.3.2 Mixer Removal

The mixer can be removed without removing the generator set enclosure. Referring to [Figure 52](#), remove the mixer as follows:

1. Disconnect the fuel hose at the mixer or at the demand regulator.
2. Disconnect the governor linkage.
3. Remove the air filter cover and filter element and remove the two support screws in the back of the filter enclosure as well as the two mixer mounting nuts.
4. Pull away the air filter enclosure and mixer.
5. Avoid removing the mixer through studs from the intake manifold. Otherwise, they will have to be replaced with new studs having factory-applied thread sealant.

The mixer is not likely to cause problems and should be replaced only after all other causes have been eliminated (see the Troubleshooting section). The mixer fuel mixture adjustments are sealed at the factory. See [Section 9.4.3](#) section to connect the throttle link and to adjust the idle (throttle) stop screw.

9.3.3 Intake Manifold Removal

1. Remove the generator set enclosure and perform steps 1 through 3 of [Section 9.3.2](#). Do not loosen the mixer mounting nuts if the air filter, mixer and manifold are to be removed as an assembly.
2. Then remove the intake manifold bolts and pull away the assembly.

9.3.4 Reassembly

Reassembly is the reverse of disassembly. Always use new gaskets when reassembling. Note the marking on the gasket between the air filter enclosure and the mixer as to which way is up and which side is out.

1. Torque the intake manifold bolts to 19 lb-ft (26 Nm).
2. If a mixer through stud came out, replace it with a new stud having factory-applied thread sealant.
3. Clean the threads in the manifold of the old sealant. Torque the stud to 5.5 lb-ft (7 Nm).
4. Make sure the air intake fits through the opening in the base and that the engine breather tube is connected between the air filter enclosure and the cylinder head.
5. To prevent damage to the air filter enclosure, first tighten the two (2) mixer mounting nuts (left first) to 4.5 lb-ft (6 Nm) and then tighten the two (2) support screws.

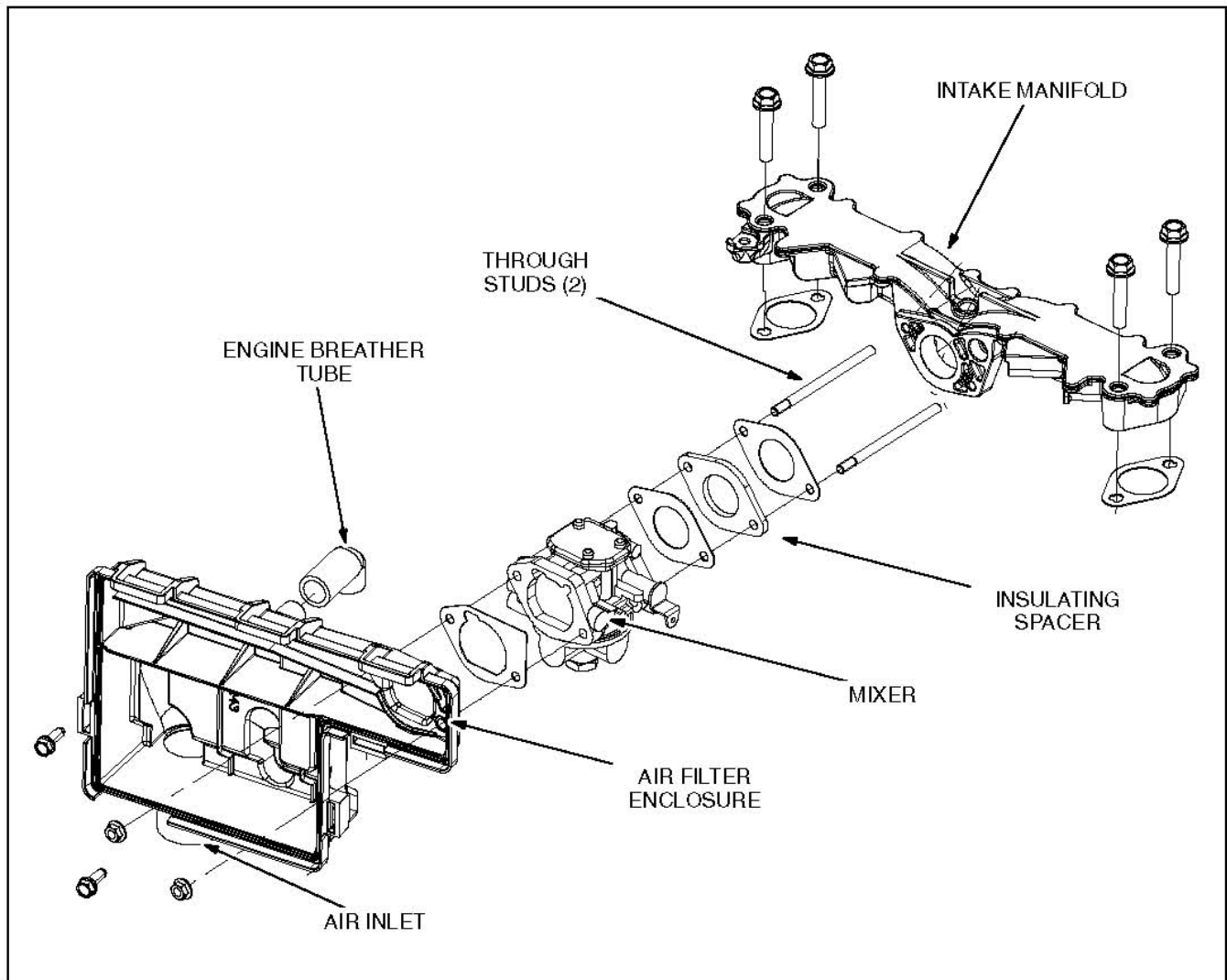

FIGURE 52. LPG MIXER AND INTAKE ASSEMBLY

9.3.5 Low-Pressure LPG Demand Regulator

Low-Pressure LPG Models have a demand regulator that meters fuel to the carburetor ([Figure 53](#)). It is usually not the cause of fuel system problems. All other possible fuel system problems should first be checked out. Then conduct a lock-off pressure test as follows before replacing a demand regulator.

Replace the demand regulator only if lock-off pressure is not within the range of 0.20 to 0.35 inches WC (5.1 to 8.9 mm).

- **Lock-Off Pressure Test:** Lock-off pressure is determined by pressurizing the back (vent) side of the regulator diaphragm to simulate carburetor venturi vacuum:
 1. Connect the regulator inlet ([Figure 53](#)) to a source of air pressure regulated to 11 inches WC (28 cm).
 2. Disconnect the hose from the carburetor at the regulator outlet. The soap bubble will be placed on the hose barb at the regulator
 3. "T" in two hoses to the end of the regulator vent hose (3/8 inch I. D.).
 4. Use one hose to measure pressure by connecting it to an inclined manometer that reads 0 to 2 inches WC (0 to 50 mm) and the other to provide the test pressure.

5. Attach a soap bubble to the hose barb at the regulator outlet.
6. While reading the pressure indicated by the manometer and watching the soap bubble, blow lightly into the hose being used to pressurize the regulator. Regulator lock-off pressure is the minimum pressure that will cause air to flow through the regulator, as indicated by the expanding soap bubble. (At first the soap bubble may expand due to diaphragm movement but will stop expanding if air is not flowing through the regulator.)

⚠ CAUTION

If this is a bench test of the regulator, make sure the diaphragm is in a vertical plane (as in the generator set), otherwise the weight of the diaphragm will cause erroneous readings of lock-off pressure.

- **Vent Hose:** Make sure to reconnect the regulator vent hose to the vent bug screen in the drip pan (Figure 73). The regulator is vented to this location to prevent variations in compartment air pressure from affecting fueling and to vent LPG outside the generator set compartment if the diaphragm develops a leak.

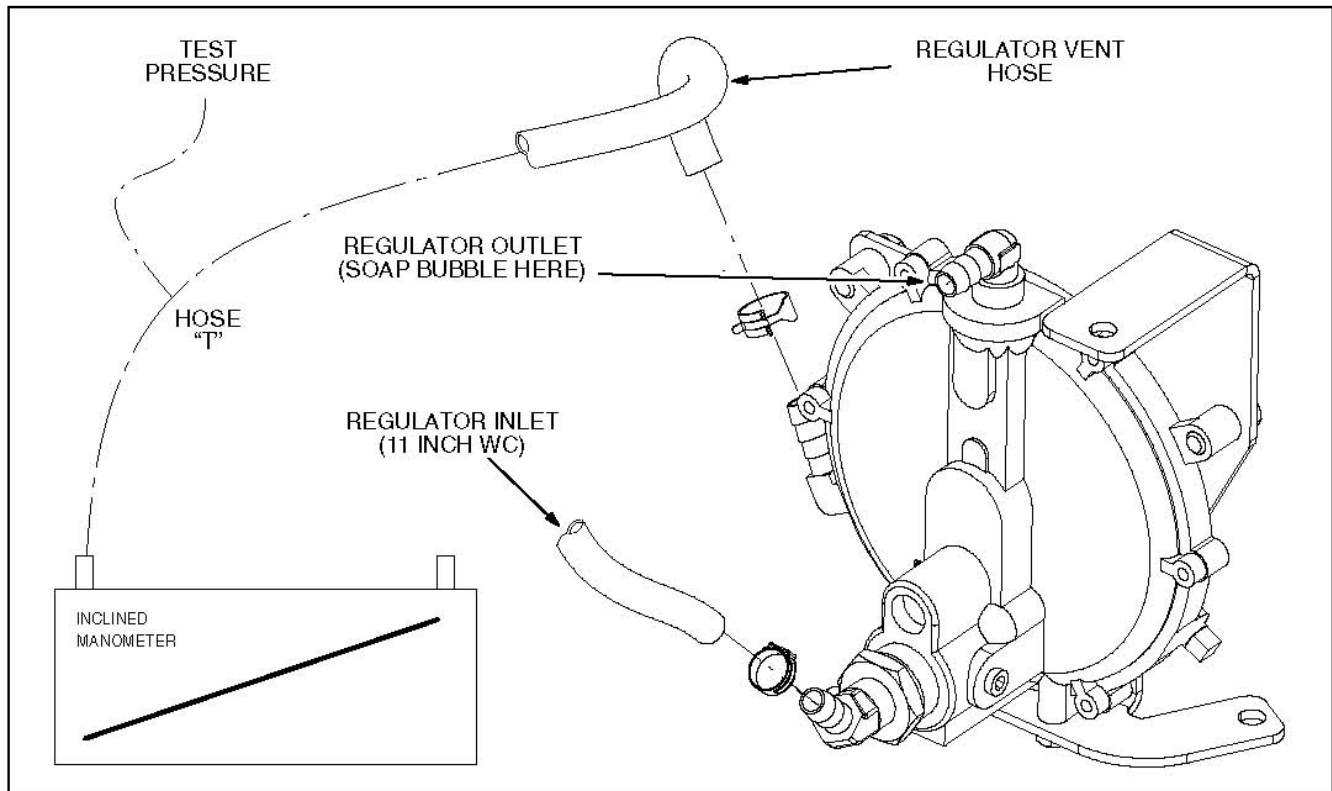

FIGURE 53. LOW-PRESSURE LPG LOCK-OFF PRESSURE TEST

9.3.6 Testing Low-Pressure LPG Shutoff E4

- **Test for Leakage:**
 1. If there is a smell of gas when the generator set is not running, or any other reason to suspect that the valve (Figure 54) is leaking, connect the inlet of the valve to a source of air pressure regulated to not more than 14 in WC (35 cm).
 2. Disconnect the outlet hose.
 3. Replace the solenoid if it leaks. Use a soap bubble to check for leakage.

- **Test for Operation:**

1. Disconnect the solenoid leads from the generator set wiring harness.
2. Connect them to a 12 V battery while the source of air pressure is still connected.
3. Replace the solenoid if it does not open.

9.3.7 Low-Pressure LPG Filter Cleaning

1. Remove the filter at the inlet to the solenoid ([Figure 54](#)), if provided.
2. Clean off debris from the filter and iron filings from the magnet.
3. Torque the filter back on to 25 lb-ft (34 Nm).

9.3.8 Low-Pressure LPG Supply Connections

⚠ WARNING

High LPG supply pressure can cause gas leaks which can lead to fire and severe personal injury or death. LPG supply pressure must be adjusted to Specifications by qualified personnel.

⚠ WARNING

Electric arcs can ignite LPG leading to severe personal injury or death. Do not run wiring and fuel lines together.

⚠ WARNING

The flameout of an unvented LPG appliance can lead to explosive accumulations of gas inside the vehicle and the danger of severe personal injury or death. Do not connect the generator set fuel supply line to any vehicle appliance supply line.

⚠ WARNING

Testing for gas leaks with a flame can cause a fire or explosion that can lead to severe personal injury or death. Use approved methods only.

- **LPG Tank Connections:** Low-Pressure LPG generator set models must be connected to the vapor withdrawal fitting on the LPG tank. The tank must have a manual shutoff valve and 2-stage pressure regulator adjusted to deliver 9-13 inches WC (23-33 cm) pressure at the generator set. The figure below shows the supply fitting on the generator set.

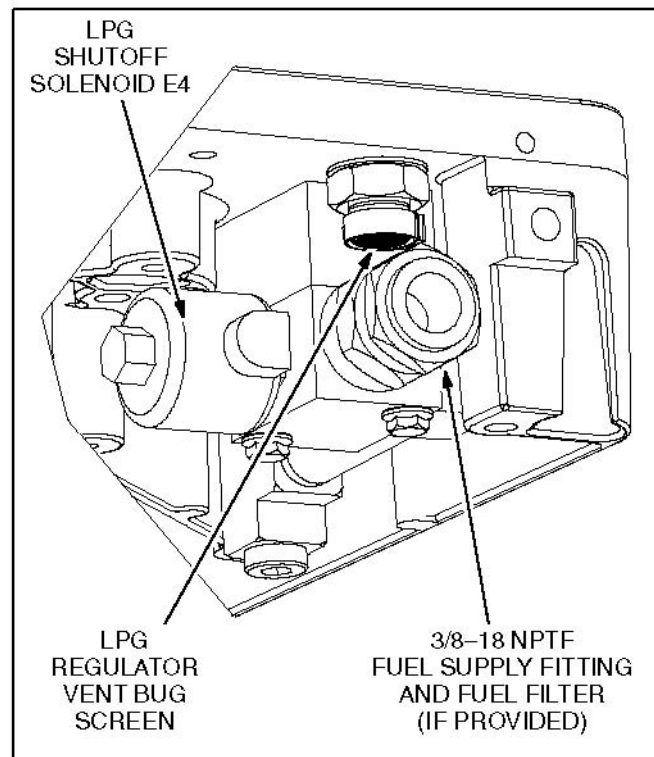

FIGURE 54. LOW PRESSURE LPG FITTING

- **Fuel Line Materials and Routing:** If it is necessary to replace the fuel lines, use approved fuel line materials of 3/8-inch I. D. for runs up to 3 ft (0.9 m) and 0.5 in I. D. for runs up to 15 ft (4.6 m).
 - Route gas lines away from hot exhaust parts and electrical wiring.
 - Provide support and protection to prevent chaffing, kinking and pinching.
 - Make sure they are accessible throughout for inspection and replacement.
- **Appliance Fuel Lines:** Do not connect the generator set fuel supply line to any appliance fuel supply line. The generator set can draw fuel away from other appliances and cause a flame out. To prevent the possibility of flameout, the fuel supply system must be designed to deliver sufficient fuel for normal operation of the generator set and other appliances at the expected temperature conditions. It may be necessary to use a separate fuel tank for the generator set if sufficient fuel cannot be supplied with a single tank system.
- **Testing for Gas Leaks:** Upon completing service, fill the LPG tank and test every joint and fitting in the LPG supply system using an approved method, such as soap bubbles.

9.3.9 High-Pressure LPG Converter (Regulator)

High-Pressure LPG Models have a converter (liquid to vapor) that also meters fuel to the carburetor ([Figure 55](#)). It is usually not the cause of fuel system problems. All other possible fuel system problems should first be checked out before replacing it.

9.3.10 Testing High-Pressure LPG Shutoff E4

- **Test for Leakage:**
 1. If there is a smell of gas when the generator set is not running, or any other reason to suspect that the valve (see the figure below) is leaking, remove the solenoid.
 2. Connect the inlet of the valve to a source of compressed air (200 psi maximum).

3. Replace the solenoid if it leaks. Use a soap bubble to check for leakage.

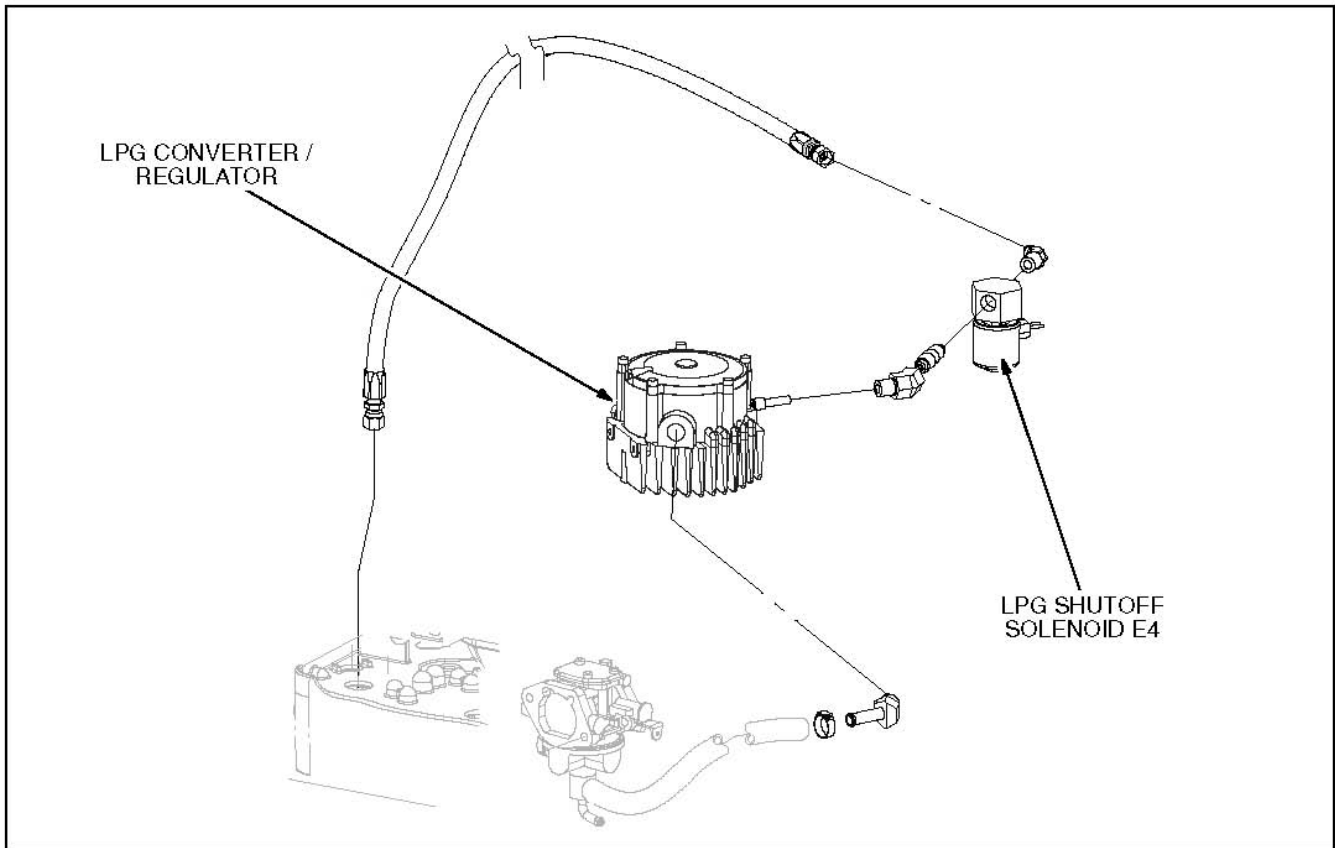

FIGURE 55. HIGH PRESSURE LPG COMPONENTS

- **Test for Operation:**
 1. Connect to a 12 volt battery while the source of air pressure is still connected.
 2. Replace the solenoid if it does not open.

9.3.11 High-Pressure LPG Filter Cleaning

1. Remove the filter at the generator set supply inlet ([Figure 56](#)).
2. Clean off debris from the filter and iron filings from the magnet.
3. Torque the filter back on to 25 lb-ft (34 Nm).

9.3.12 High-Pressure LPG Supply Connections

⚠ WARNING

Electric arcs can ignite LPG leading to severe personal injury or death. Do not run wiring and fuel lines together.

⚠ WARNING

Testing for gas leaks with a flame can cause a fire or explosion that could lead to severe personal injury or death. Use approved methods only.

- **LPG Tank Connections:** High-pressure LPG generator set models must be connected to the liquid withdrawal fitting on the LPG tank. Use the Standard for the Storage and Handling of Liquefied Petroleum Gases (NFPA No. 58) as a guide for the installation of a High-Pressure LPG fuel system. The figures below shows the supply fitting on the generator set.

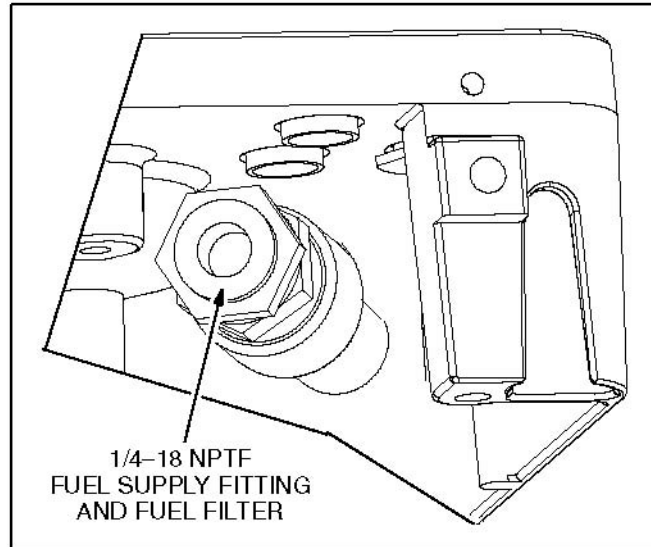

FIGURE 56. HIGH-PRESSURE LPG FI

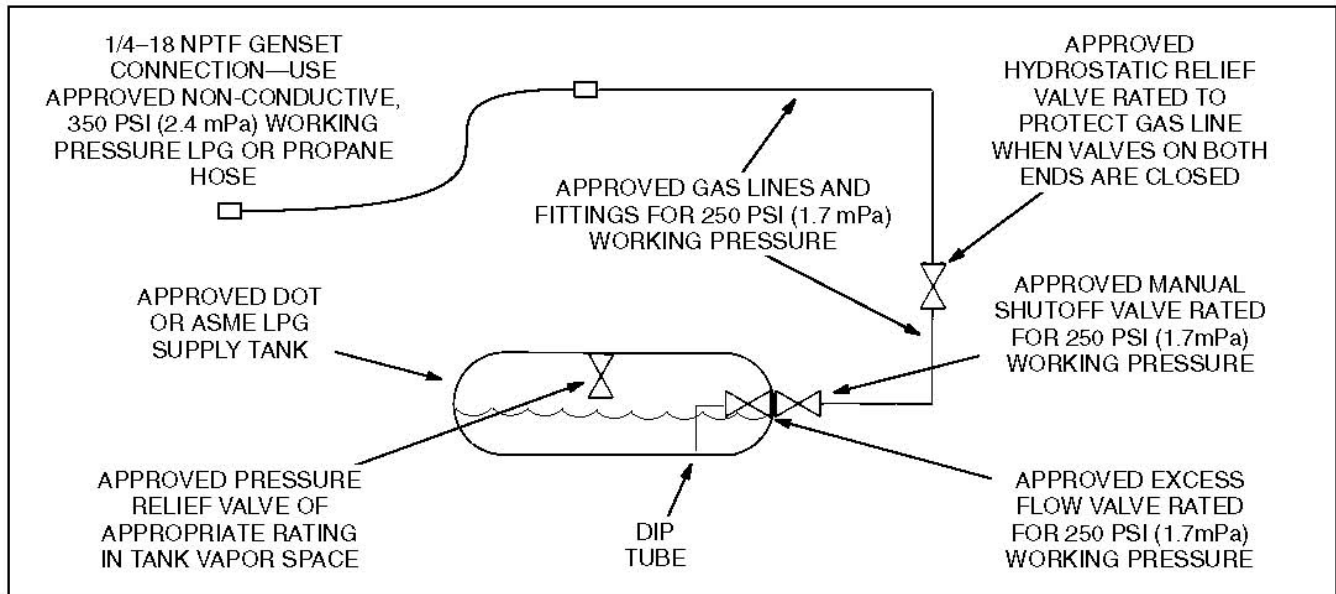

FIGURE 57. TYPICAL HIGH-PRESSURE LPG SUPPLY SYSTEM (LIQUID WITHDRAWAL)

- **Fuel Line Materials and Routing:**

1. Connect the generator set to the LPG supply line with a flexible hose that is non-conductive between its end fittings so that the fuel line cannot become an alternative path for cranking currents. The hose must be listed for **350 psi working pressure and LP-Gas or Propane**.

2. Route gas lines away from hot exhaust parts and electrical wiring.
3. Provide support and protection to prevent chaffing, kinking and pinching.
4. Make sure they are accessible throughout for inspection and replacement.

- **Testing for Gas Leaks:**

1. Upon completing the installation, fill the LPG tank.
2. Test every joint and fitting in the LPG supply system using an approved method, such as soap bubbles.

9.4 Mechanical Governor—HGJAB and HGJAE

⚠ CAUTION

Voltage/frequency-sensitive equipment such as VCRs, televisions, computers, etc. may be damaged by power line frequency variations. Some solid-state devices are powered whenever connected to an AC outlet even if the device is not in actual operation. For this reason, disconnect all devices which are voltage or frequency-sensitive before attempting any carburetor/governor adjustments. If disconnecting the devices is not possible, open the circuit breaker(s) at the distribution panel or at the generator set, if so equipped.

The mechanical governor ([Figure 58](#)) operates the throttle plate in the carburetor or mixer to maintain constant engine speed (within a range of 5%) as load varies. See [Section 10.8.12](#) regarding the internal governor parts.

See [Table 13](#) for rated voltage and frequency versus allowable voltage range and droop (the difference between no-load frequency and full-load frequency).

TABLE 13. VOLTAGE/FREQUENCY/DROOP

Rated Voltage	Voltage		Frequency	
	Max No Load	Min Full Load	No Load	Droop
60 Hz Generator Sets				
100	108	93	63/62	2-4
120	125	112	63/62	2-4
200	216	186	63/62	2-4
240	250	224	63/62	2-4
50 Hz Generator Sets				
100	108	93	52.5/51.5	2-4
200	216	186	52.5/51.5	2-4
220	238	205	52.5/51.5	2-4
230	249	215	52.5/51.5	2-4
240	250	224	52.5/51.5	2-4

Before making governor adjustments, check for other causes of hunting or excessive droop, such as binding governor linkage, fouled spark plugs, improper valve lash, and dirty fuel filters.

Accurate governor adjustments require a variable load bank of up to 7 kW capacity and accurate meters for measuring frequency (within 0.3%), voltage (within 0.5%) and output current (AC).

9.4.1 Assembling Governor Linkage

Reassemble the throttle link and its tension spring if they have not been assembled as shown in [Figure 58](#). The easiest way is to hook both ends of link and spring while the governor arm is detached.

1. Detach the governor arm:
 - a. Remove the governor shaft nut by turning it **clockwise**.
 - b. Pull the arm away from the shaft hub.
2. While the governor arm is detached, hook the tension spring below the throttle link in the throttle lever so that it can pull down on the bottom of the hole while the throttle link can push up on the top of the hole, without interfering with each other.
3. To reattach the arm, see the Resetting Governor Arm section.

9.4.2 Resetting Governor Arm

Anytime the carburetor or governor linkage has been disturbed by disassembly and reassembly, it will be necessary to reset the governor arm on the governor shaft, as follows (see [Figure 58](#)):

1. Loosen the governor shaft nut by turning it **clockwise** and remove the arm.
2. Use a battery terminal puller or equivalent tool to break the taper fit of the shaft in the arm hub.
3. Reattach arm and hub, making sure the two pins and holes engage, and thread the shaft nut on **counterclockwise**. Check for free rotation of the arm around the shaft and let the governor spring take up all play in the linkage. The linkage must push the throttle up against the wide open throttle stop.
4. Torque the shaft nut to 8 lb-ft (11 Nm), **counterclockwise**. (By design, tightening counterclockwise takes up play between the internal governor parts.)
5. Gently push the governor arm down and check for binding, rubbing against adjacent parts, interference with wiring and looseness.

9.4.3 Adjusting Governor

Adjust the governor as follows (see the figure below):

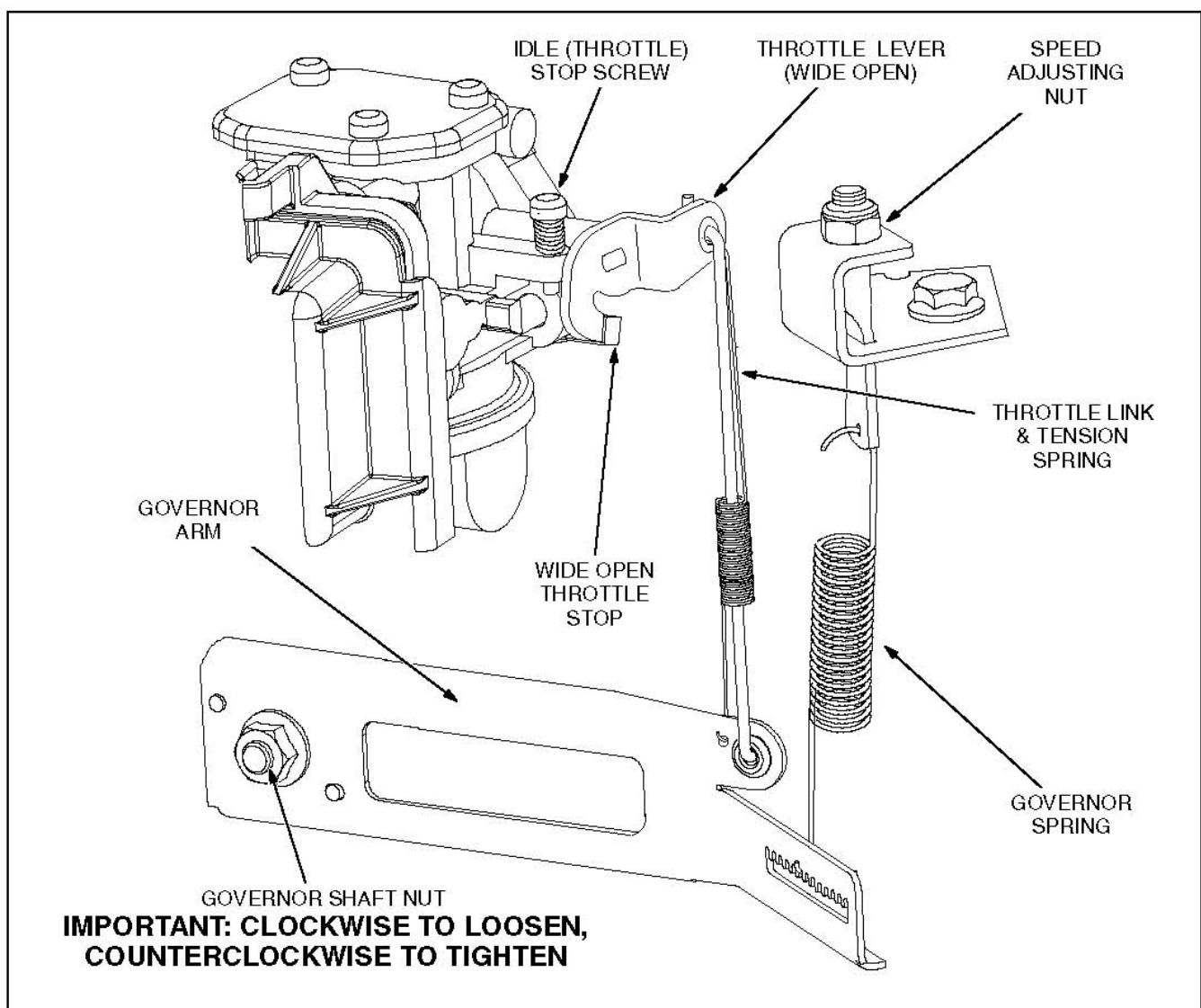

FIGURE 58. MECHANICAL GOVERNOR

1. Warm up the generator set for at least 5 minutes at 1/2 to 3/4 rated load. The choke must be completely open.
2. Adjust frequency as close as possible to the appropriate [Table 13](#) value with the speed adjusting nut to keep the generator set from shutting down (most likely on Fault 14—Overfrequency or Fault 15—Underfrequency). Restart in 5 seconds if it shuts down.
3. When the engine is warm, remove all loads and adjust the idle (throttle) stop screw to obtain 51 to 53 Hz on a 60 Hz generator set, or 41 to 43 Hz on a 50 Hz generator set, holding down the throttle lever with your finger.
4. Let the throttle lever go.
5. Recheck and re-adjust the no-load frequency (speed), as necessary, according to [Table 13](#).
6. Bump the governor arm to see that frequency stabilizes.
7. Connect a rated load.
8. If the droop is greater than specified in [Table 13](#), move the governor spring hook one or two notches towards the governor shaft and recheck frequency and droop.

9. Repeat the procedure as necessary.
10. If the droop is less than specified, or the generator set hunts, move the spring hook one or two notches away from the governor shaft.
11. Recheck the frequency and droop. Repeat the procedure as necessary.
12. Make sure the governor is not hunting by checking under the following loading sequence:
 - a. No-Load
 - b. 3/4-Load
 - c. No-Load
 - d. 1/2-Load
 - e. No-Load
 - f. 1/4-Load
 - g. No-Load
13. See [Section 5.1 Troubleshooting](#) if output voltage does not fall within the range specified in [Table 13](#).
14. Check for binding, interference with wiring and rubbing against adjacent parts. Reset the governor arm if governor performance does not improve.

10 Engine

10.1 Testing Compression/Leakdown

Test engine compression and/or leakdown to confirm whether the engine is worn. Compression should fall between 153 and 188 psi, and not vary between cylinders by more than 10%.

10.2 Testing Crankcase Vacuum

Test crankcase vacuum to confirm whether the engine is worn or the breather valve is malfunctioning. Vacuum should be 7 to 10 inches of water column as measured through a tap in the oil fill cap.

10.3 Removing and Installing Alternator/Engine Assembly

[Figure 59](#) illustrates how the engine is mounted on the alternator/engine base. The flywheel, exhaust manifold and mounting bolts are accessible for removal on the bottom side of the base.

10.3.1 Removal

1. Drain the engine oil because the generator set will be turned on its side to remove components.
2. Remove the two-piece control enclosure.
3. Disconnect:
 - a. The AC output leads from their terminals on the circuit breakers and base
 - b. The grounding strap at the alternator/engine base
 - c. The fuel pump or fuel solenoid leads
 - d. The fuel lines from the engine:
 - At the fuel filter outlet (supply) and pressure regulator (return) on EFI models
 - At the carburetor or LPG regulator on other models
4. *For HGJAA, HGJAB, HGJAD and HGJAE models only:*
 - a. Disconnect the engine exhaust outlet at the muffler flange.
 - b. Remove the heat shield between the muffler and engine.
5. If the engine will be separated from the base, disconnect all wiring from the engine:
 - a. Spark plug cables (2)
 - b. Ignition kill (2)
 - c. Starter motor and solenoid
 - d. Low oil pressure cutoff switch
 - e. *EFI models only:* The governor actuator, fuel injector, and MAP and MAT sensors
 - f. *Models with carburetors only:* The choke heater and fuel cutoff

⚠ CAUTION

To prevent damage, do not rest the alternator/engine assembly on its fan shroud. Instead place blocks under the assembly when it is rested upside-down so that the weight will not bear on the choke pulloff diaphragm (gasoline carburetors).

6. Remove the two fail-safe bolts.
7. Four 3/8-16 holes, one in each corner, are provided for lifting and support. With assistance, lift the alternator/engine assembly off its four mounting springs and rest it upside-down.
8. Remove the following from the alternator/engine assembly:
 - a. The engine
 - b. The drive belt
 - c. The exhaust manifold or ignition coils (magnetos)

10.3.2 Installation

1. Perform the reverse of the removal steps, as shown in the Removal section.
2. Torque the fail-safe bolts to 51 Nm (38 lb-ft).
3. Check that the assembly floats freely on its springs and does not make contact with the drip pan.

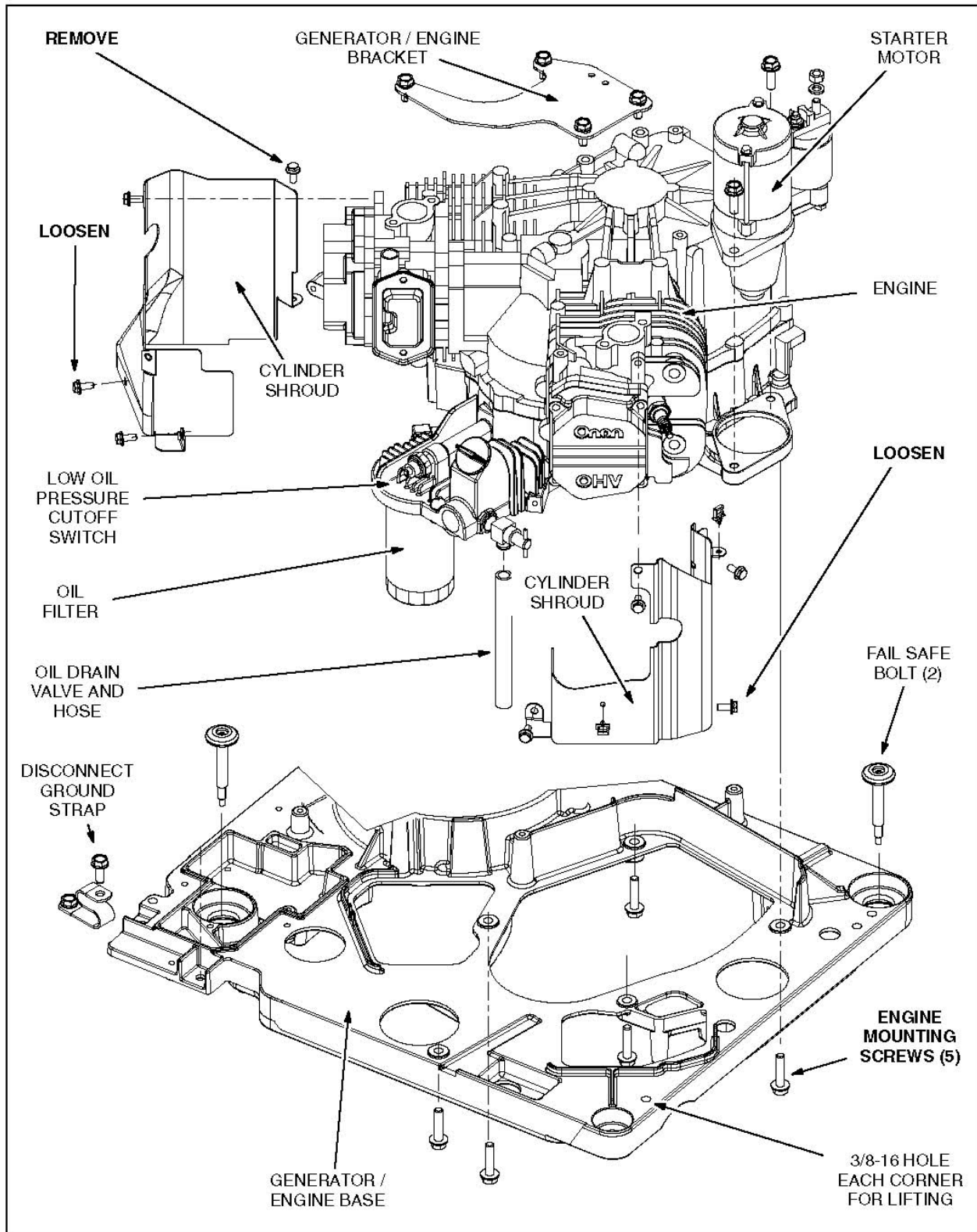

FIGURE 59. ENGINE

10.4 Removing and Installing Engine

10.4.1 Removal

1. Unless it has already been performed, disconnect all wiring from the engine.
2. Remove the alternator/engine bracket and loosen, or remove the cylinder shroud screws shown in [Figure 59](#).
3. Remove the ignition coils, flywheel, and exhaust manifold ([Chapter 8](#)).
4. Remove the five screws securing the engine to the alternator/engine base and lift off the base.

10.4.2 Installation

Installation is the reverse of removal. Torque the engine mounting screws to 20 lb-ft (27 Nm). Torque the cylinder shroud screws to 8 lb-ft (11 Nm).

10.5 Starter Motor

10.5.1 Starter Motor Replacement

- To remove the starter motor ([Figure 59](#)), disconnect all wiring and remove the two mounting screws. Follow the instructions in the starter motor kit if the starter is going to be repaired.
- To install the starter motor, torque the mounting screws to 20 lb-ft (27 Nm) and the terminal nut to 6.5 lb ft (8 Nm).

10.5.2 Starter Motor Solenoid Replacement

⚠ WARNING

This test involves high electrical currents, strong arcing and moving parts that can cause severe personal injury. Do not conduct this test near fuel tanks or when flammable vapors are present. Wear safety glasses. Keep fingers away from the pinion gear.

The starter solenoid is separately replaceable. To determine whether the problem is in the solenoid or in the motor:

1. Secure the motor assembly in a vice after it has been removed from the generator set.
2. Using a heavy jumper cable, because of the large currents involved, connect the motor terminal on the solenoid (the one closest to the motor) to the positive (+) terminal on a 12 volt battery.
3. Using a heavy cable from the negative (-) terminal on the battery, briefly touch the mounting flange on the motor.
 - If the motor does not spin up quickly and smoothly, replace the motor/solenoid assembly.
 - If the motor does spin up quickly and smoothly, the motor is probably okay, replace the solenoid by disconnecting the motor lead from the solenoid terminal and removing the two solenoid mounting nuts.

NOTICE

When installing a new solenoid, make sure the solenoid plunger engages the shift fork.

10.6 Valve Lash Adjustment

Valve lash is adjustable through the maintenance access opening on generator sets with enclosures. Access to Cylinder No. 1 requires removal of the air filter enclosure. See [Section 9.1](#), [Section 9.2](#) or [Section 9.3](#), depending on fuel system.

NOTICE

For accurate adjustments, valve lash must be adjusted when the engine is at room temperature.

1. Torque the adjustment lock nut while using a wrench to prevent the holding nut from turning (see the figure below) to 6.5 lb-ft (8.5 Nm) and recheck lash.

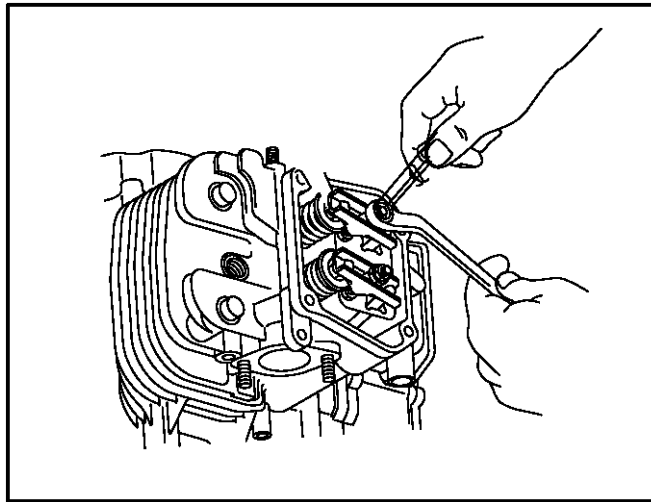

FIGURE 60. TORQUE THE ADJUSTMENT LOCK NUT

2. Remove the spark plugs so that the engine is easier to turn over.
3. Use a socket wrench on the alternator pulley nut to turn the engine.
4. Remove the snap-in cover in the access hole in the drip pan. Always turn clockwise so that the nut does not loosen.
5. Remove the valve covers. Have rags in place to catch the oil that spills out.
6. Turn the engine until the Cylinder No. 2 intake valve (top) is at maximum lift.

NOTICE

The intake valves are the upper ones, and the exhaust valves are the lower ones; Cylinder No. 1 is to the left (generator side), and Cylinder No. 2 is to the right.

7. Adjust Cylinder No. 1 intake valve lash.

NOTICE

Adjust valve lash (see the figure below) for all valves to 0.004 in (0.01 mm).

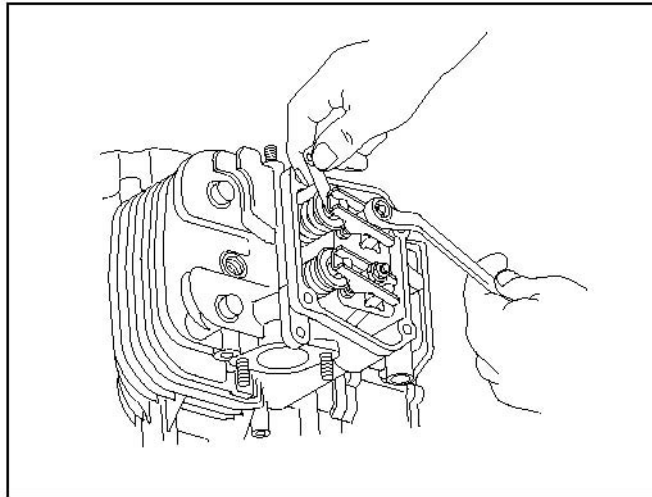

FIGURE 61. ADJUSTING VALVE LASH

8. Turn the engine until the Cylinder No. 2 exhaust valve (bottom) is at maximum lift.
9. Adjust Cylinder No. 1 exhaust valve lash.
10. Turn the engine until the Cylinder No. 1 intake valve (top) is at maximum lift.
11. Adjust Cylinder No. 2 intake valve lash.
12. Turn the engine until the Cylinder No. 1 exhaust valve (bottom) is at maximum lift.
13. Adjust Cylinder No. 2 exhaust valve lash.
14. Secure the valve covers using new gaskets. Torque the cover screws to 5.5 lb-ft (8 Nm).
15. Replace the spark plugs and pulley nut cover.

The following procedure is recommended:

10.7 Cylinder Heads and Valves

The cylinder heads are removable after the intake and exhaust manifolds have been removed. See [Chapter 9](#) regarding removal of the intake manifold. See [Section 8.3](#) regarding removal of the exhaust manifold.

10.7.1 Removal and Disassembly

To remove the heads from the crankcase, and valves from the heads:

1. Remove the valve covers for access to two of the four head bolts. Have rags in place to catch the oil that spills out.
2. Remove the four head bolts and pull away the head.
3. If the valves are to be removed, place the head on a flat surface and push down on the valve spring retainers, remove the collets and disassemble.
4. Clean the parts thoroughly. Check head flatness, spring free length, valve seat angle and contact width, valve stem diameter and valve guide I. D. against DIMENSIONS AND CLEARANCES ([Section 10.9](#)) and replace parts as necessary. Replace burned, pitted or bent valves.

10.7.2 Reassembly and Installation

Reassembly and installation are the reverse of disassembly and removal.

1. Lap each valve in place until a uniform ring shows around the face of the valve.
2. Apply oil to the valve stems.
3. Install new valve stem seals.
4. Check the head dowel pins. Replace if necessary.
5. Install new head gaskets.
6. Torque the head bolts in three steps as follows:
 - a. Torque to 7.2 lb-ft (9.8 Nm).
 - b. Torque to 14.5 lb-ft (19.6 Nm).
 - c. Torque to 24.6 - 30.4 lb-ft (33.3 - 41.2 Nm).
7. Assemble the push rods and rocker arms.
8. Adjust valve lash.

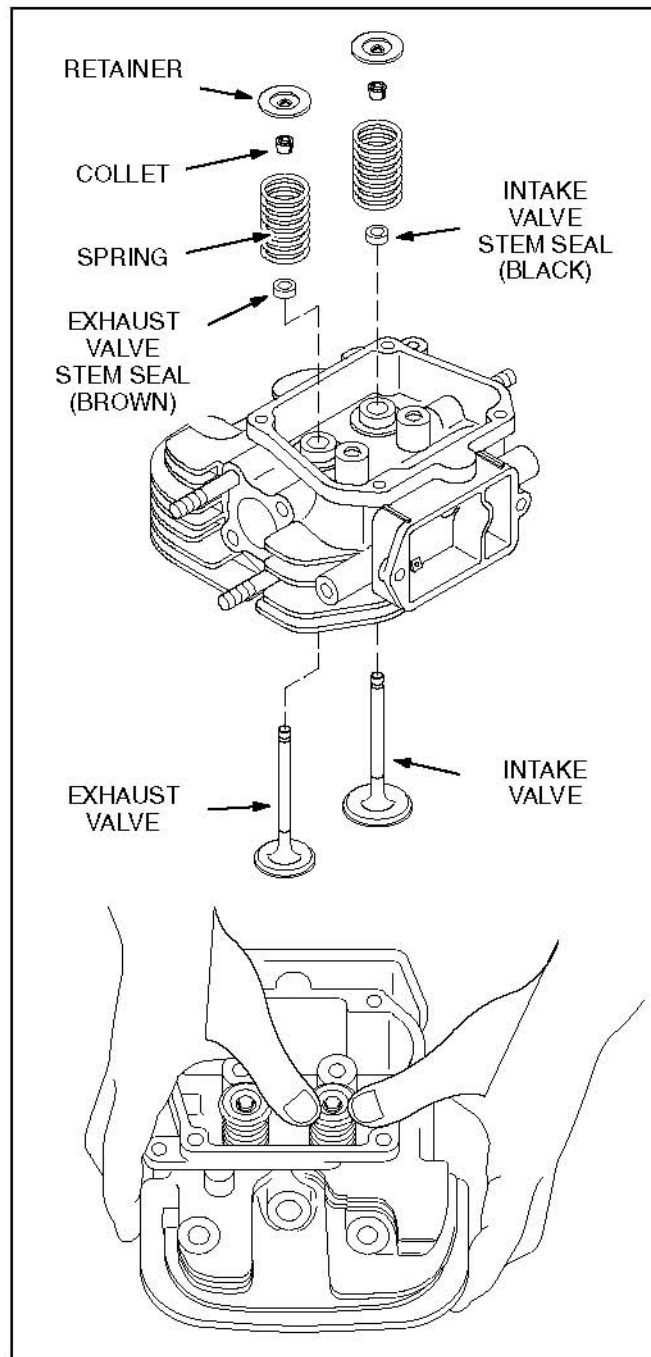

FIGURE 62. CYLINDER HEAD AND VALVES

10.7.3 Rocker Arms and Push Rods

After the heads have been assembled to the crankcase the push rods and rocker arms can be assembled loosely as shown in [Figure 63](#). Oil the rocker arms and pivots. Insert the push rods into the hollows in the tappets in the crankcase. Adjust valve lash.

10.7.4 Breather Valve

The engine breather is located on the Cylinder No.1 head and consists of a leaf valve ([Figure 64](#)). The valve maintains a partial vacuum in the crankcase and provides some separation of crankcase gases and oil. The crankcase gases are routed to the air intake for burning in the combustion chambers.

1. Remove, clean and examine the parts and replace as necessary.
2. Re-install the reed valve so that it opens out. Do not tighten the cover screws to more than 3 lb-ft (4 Nm), or the gaskets may be damaged.
3. Make sure to reconnect the tube between the breather outlet and the back of the air filter.

10.8 Crankcase Assembly

10.8.1 Disassembly

1. Remove the engine from the base ([Section 10.4](#)).
2. Turn it on its back.
3. Remove the main bearing cover screws.
4. Gently tap the cover with a soft-faced hammer to loosen it.
5. If the crank and pistons are to come out, remove the cylinder heads ([Section 10.7.1](#)).
6. Remove the camshaft and tappets.
7. Remove the pistons and connecting rods.
8. Remove the crankshaft.
9. Mark each part so that it can be reassembled with its mating parts.

10.8.2 Assembly

1. Before reassembling the crankcase ([Figure 65](#)), clean all parts thoroughly and check each against the Dimensions and Clearances section.
2. Replace or machine parts as necessary.
3. Replace all gaskets with new.
4. Liberally oil all rotating and sliding parts as they are being assembled.
5. Reassemble the crankcase in the sequence of numbered steps that follow, beginning on ([Section 10.8.12](#))

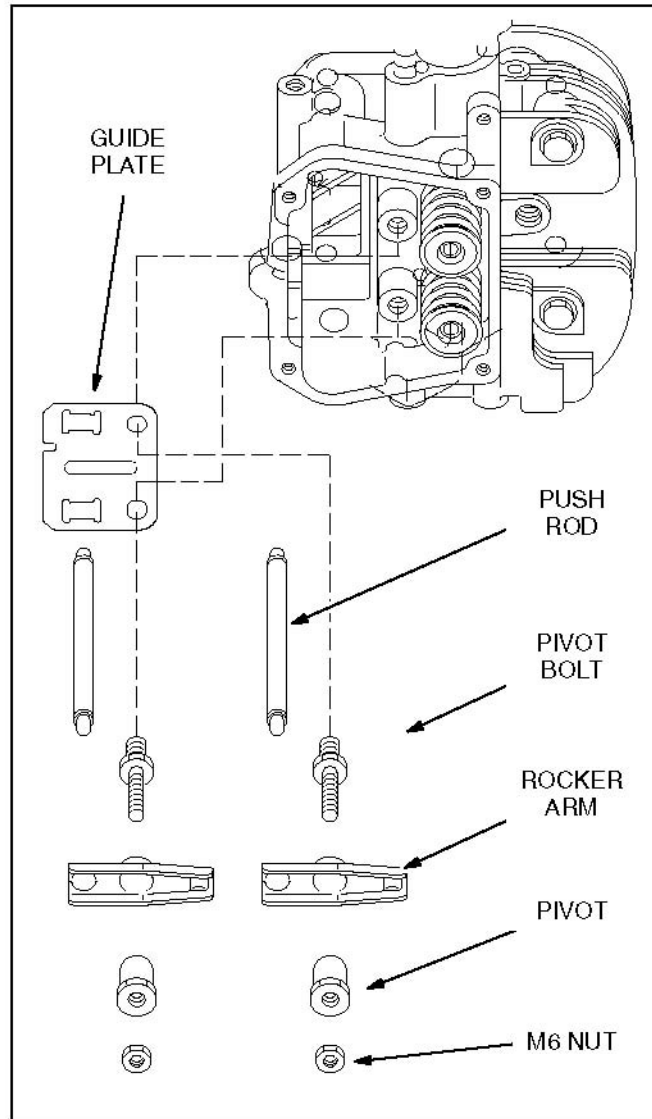

FIGURE 63. ROCKER ARMS AND PUSH RODS

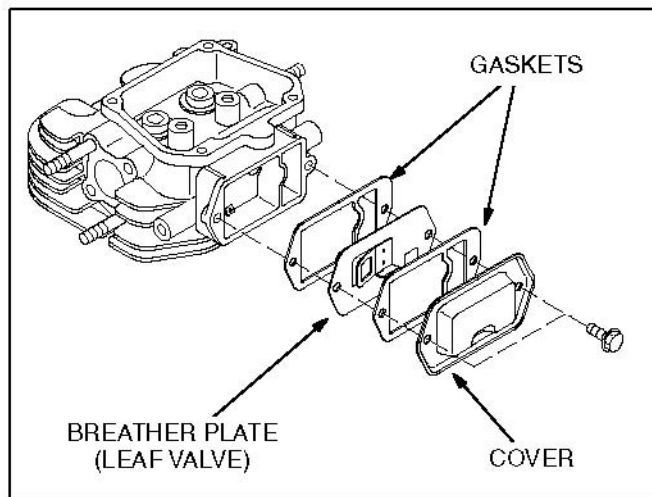

FIGURE 64. ENGINE BREATHER VALVE

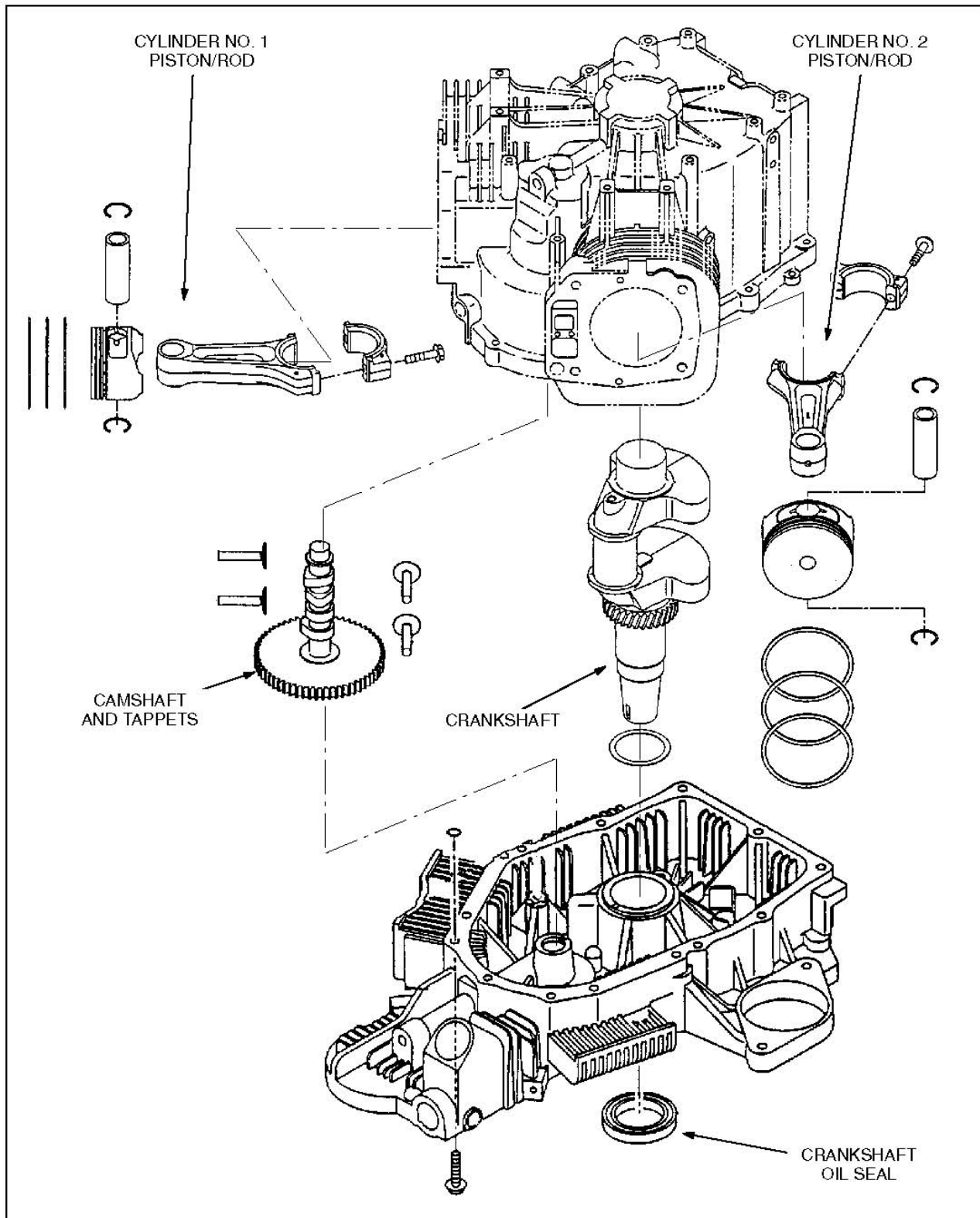

FIGURE 65. CRANKCASE ASSEMBLY

10.8.3 Crankshaft

On Models HGJAB and HGJAE install the governor lever and then the crankshaft ([Figure 66](#)).

10.8.4 Piston Rings

Install the oil ring (bottom) first, then the middle ring and last the top ([Figure 67](#)). The top ring can be installed either side up. The middle ring has a punch mark on the side that must be up.

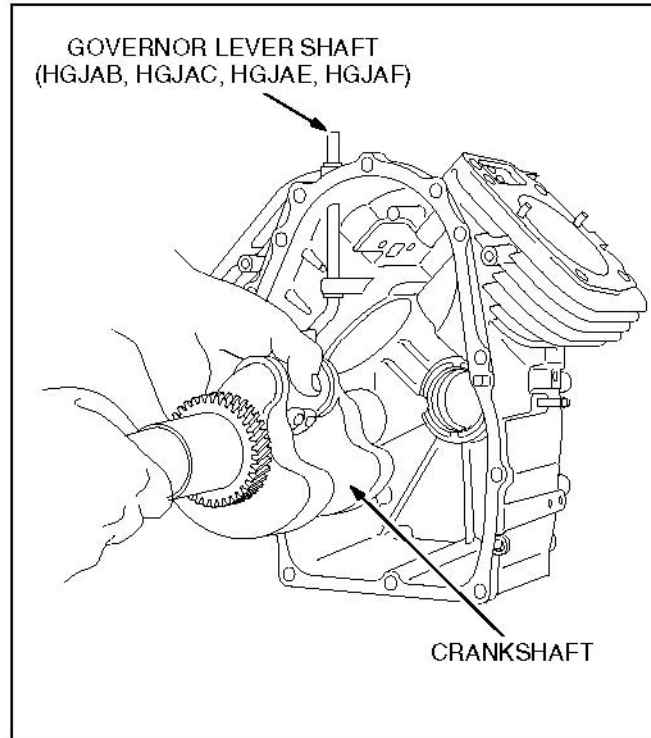

FIGURE 66. INSTALLING CRANKSHAFT

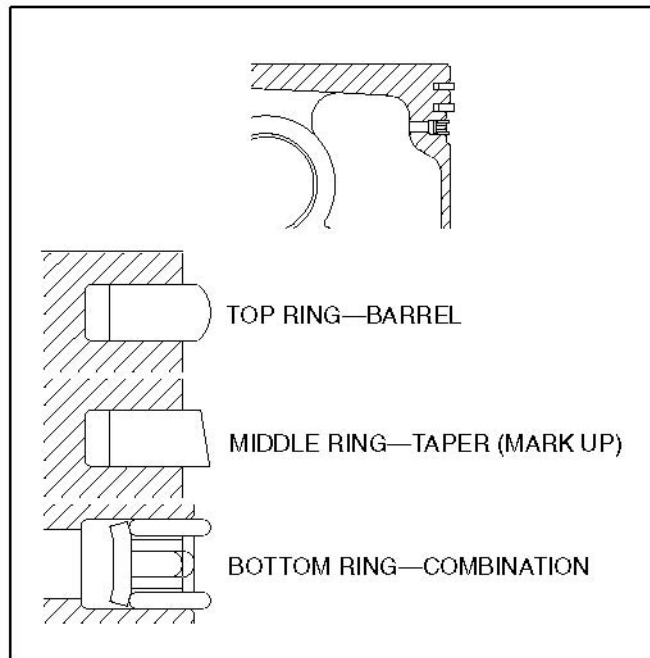

FIGURE 67. PISTON RINGS

10.8.5 Piston/Connecting Rod Assembly

1. Assemble the pistons and connecting rods using both circlips to hold the piston pin in the piston. Note that one connecting rod is marked "1" and the other "2" ([Figure 68](#)).
2. Assemble in the respective cylinder with the markings on the main bearing cover side.
3. When installing the connecting rod caps, make sure the alignment marks register ([Figure 69](#)).
4. Torque the cap bolts to 16.3-19.9 lb-ft (22.1-27 Nm).
5. Check for free movement of piston and connecting rod by turning the crankshaft slowly.

10.8.6 Camshaft and Tappets

Reinstall the tappets in their original bores. Push them in fully to avoid damage during camshaft installation. Install the camshaft and line up the timing marks with the crankshaft gear ([Figure 70](#)).

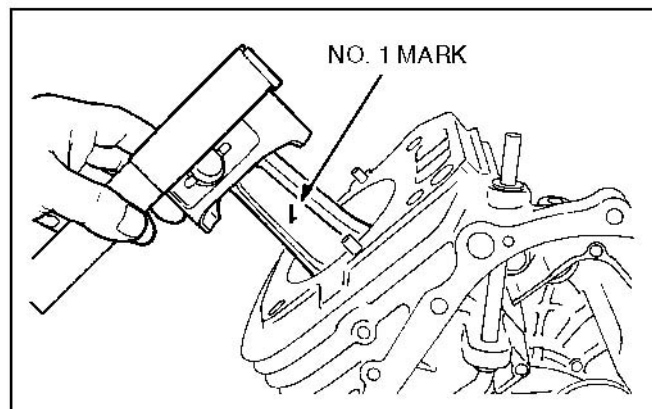

FIGURE 68. INSTALLING PISTON / ROD

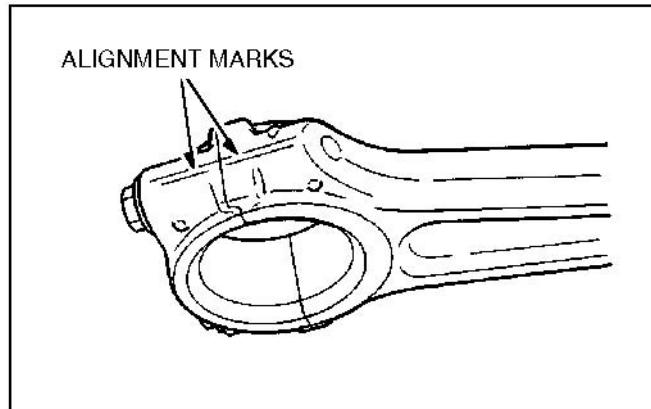

FIGURE 69. ROD ALIGNMENT MARKS

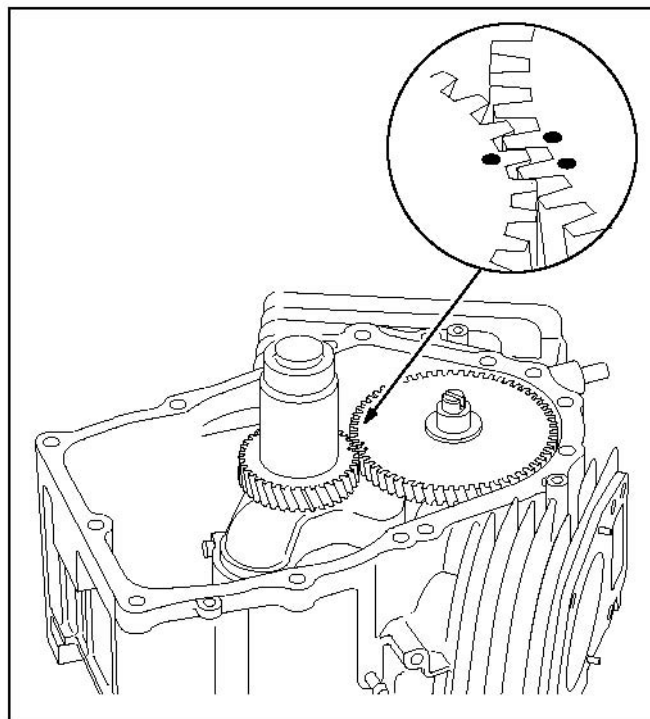

FIGURE 70. TIMING MARKS

10.8.7 Crankshaft End Play

Check and adjust crankshaft end play with spacer shims. Three thicknesses are available: 0.6, 0.8 and 1.0 mm (0.024, 0.031 and 0.039 inch). To pick the best shim:

1. Measure and record the A and B distances ([Figure 71](#)). [Figure 72](#) shows a method for determining the B distance. B is equal to Reading 1 minus Reading 2.
2. The thickness of the compressed gasket is 0.014 inch (0.36 mm). Thus:
3. $A + 0.014 \text{ inch} - B = \text{Clearance (inch)}$
 $[A + 0.36 \text{ mm} - B = \text{Clearance (mm)}]$
4. Thus, to obtain an end play of 0.008 inch (0.2 mm):
5. $\text{Clearance (inch)} - 0.008 \text{ inch} = \text{Shim Thickness (inch)}$

[Clearance (mm) - 0.2 mm = Shim Thickness (mm)]

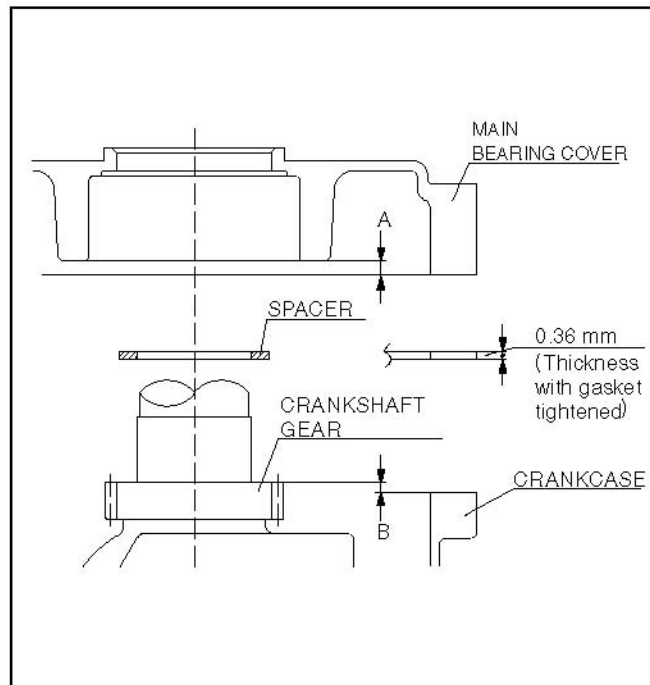

FIGURE 71. CRANKSHAFT END PLAY

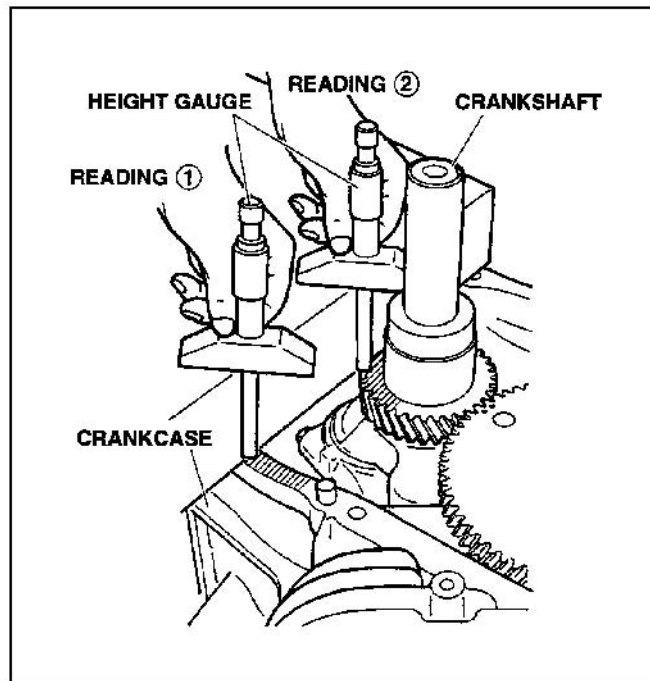

FIGURE 72. CRANKSHAFT END PLAY

10.8.8 Crankshaft Oil Seal

Press a new crankshaft oil seal into the main bearing cover to a depth of 0.020 to 0.060 inches (0.5 to 1.5 mm) below the surface.

⚠ CAUTION

Pressing the oil seal in too far will result in an oil leak.

If the crankshaft has been grooved or has nicks or scratches where the oil seal touches the crankshaft, it is recommended that a "Speedi-Sleeve" be installed. See **PSB 686** for "Speedi-Sleeve" use and installation instructions.

10.8.9 Main Bearing Cover

1. Install a seal guide over the crankshaft to protect the crankshaft oil seal.
2. *On models HGJAB and HGJAE only*, make sure the governor gear ([Section 11.1](#)) has been installed.
3. Use a new cover gasket and 3-Bond or an RTV adhesive sealant equivalent to Dow Corning 732.
4. Make sure both O-rings (187-6239) are in place, one at each oil return hole from the block.
5. Lubricate the oil seal lip.
6. Gently guide the cover on over the crankshaft to prevent damaging the oil seal, making sure that the governor gear meshes with the camshaft gear. If necessary, poke a thin rod through the gap between crankcase and cover to turn the governor gear slightly so that the teeth mesh.
7. Torque the cover screws to 16.2-16.9 lb-ft (22-23 Nm).

NOTICE

Replace all cover screws that are not imprinted with the number "9" with Cummins Part Number 800-6361. These are newer, stronger screws necessary for securing the cover tighter to prevent oil leaks.

10.8.10 Oil Pump Lubrication

The crankshaft and camshaft journals are pressure-lubricated, while the cylinders and valve system are lubricated by the oil mist in the crankcase. The oil pump is driven by the camshaft through a coupling on the end of the camshaft. A full-flow oil filter and low oil pressure cutoff switch are mounted externally ([Figure 59](#)).

NOTICE

Low Oil Pressure Switch: The generator set controller will blink Fault Code No. 2—Low Oil Pressure if there is a loss of oil pressure (less than 17 psi). Nominal oil pressure is 43 psi. See the Troubleshooting section.

1. **Oil pump removal:**
 - a. To remove the oil pump for service (see the figure below), it will be necessary to remove the flywheel but not to remove the engine from the base. See the [Chapter 8](#) section to remove the flywheel.

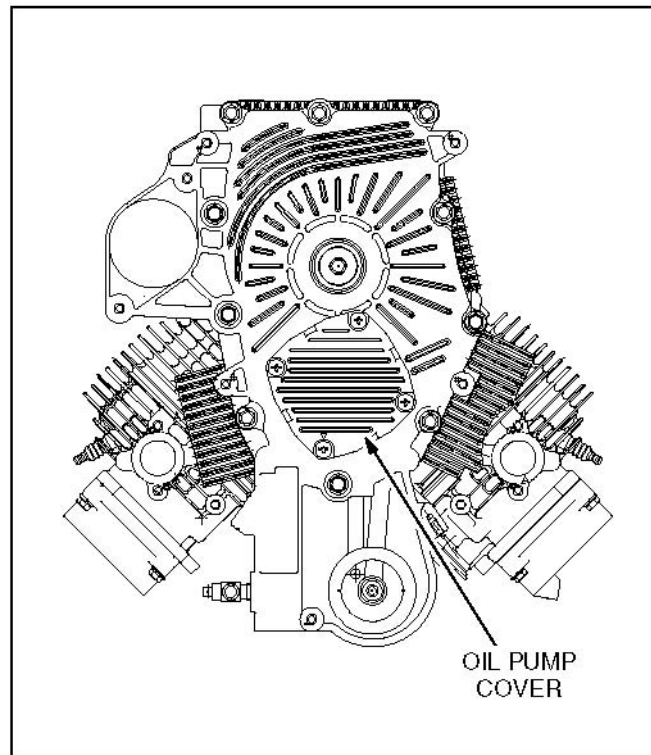

FIGURE 73. OIL PUMP COVER (ENGINE BOTTOM)

- b. Remove the four mounting screws and remove the pump components See the figure below.

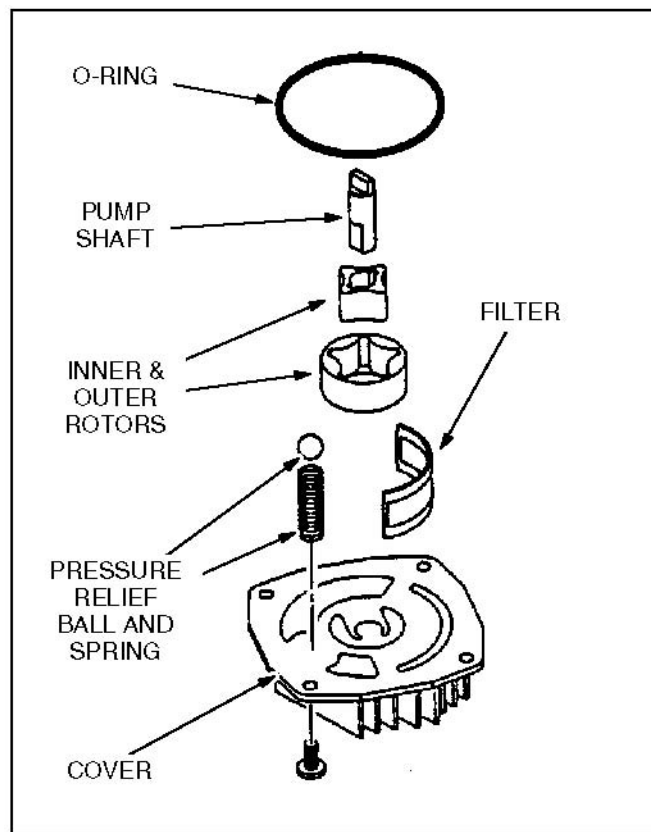

FIGURE 74. OIL PUMP

2. Oil pump reinstallation:

- a. Clean, service and replace pump parts as necessary ([Figure 74](#)).
- b. Re-lubricate before installing.
- c. Make sure the shaft engages the end of the camshaft properly.

10.8.11 Oil Control Leaf Valves

A leaf valve is secured by two screws and a retainer plate in the push rod compartment alongside each cylinder ([Figure 75](#)). The valves control the mist of crankcase gases and oil that pass through the heads lubricating the valve system. The oil drops out and returns to the crankcase through passages in the heads and crankcase while the breather valve ([Section 10.7.4](#)) prevents accumulation of the crankcase gases.

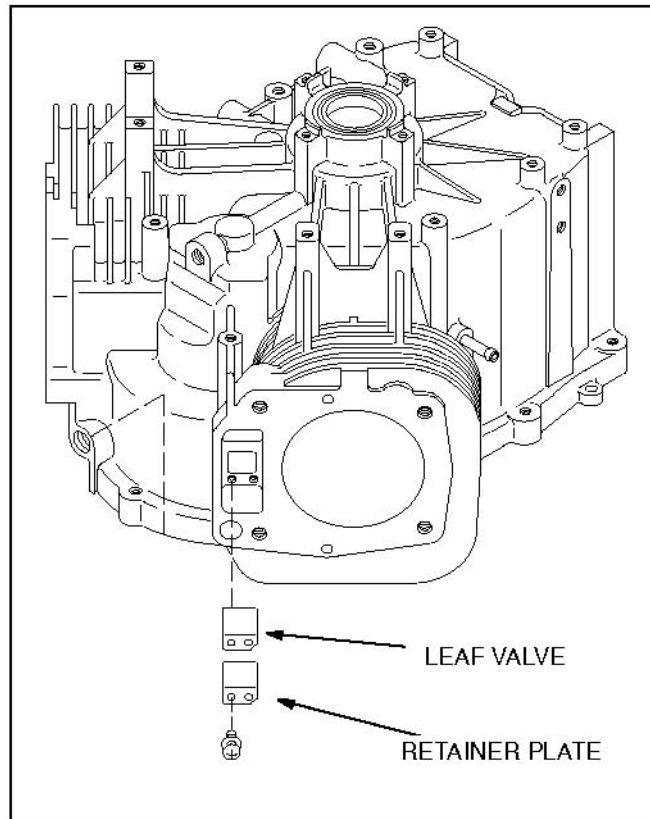

FIGURE 75. OIL CONTROL LEAF VALVES

10.8.12 Mechanical Governor—HGJAB and HGJAE

The internal components of the mechanical governor are accessible when the main bearing cover is removed. The governor gear assembly rotates on a shaft projecting from the bearing cover and snaps in place in the groove in the shaft ([Figure 78](#)). It is driven by the camshaft gear. The governor lever is carried in the crankcase and protrudes out the side ([Figure 76](#)), where the governor arm is attached ([Section 9.4.3](#)). The governor sleeve ([Figure 78](#)) pushes up on the paddle of the governor lever shaft ([Figure 76](#)). It opposes, in proportion to engine speed, the force of the external governor spring ([Section 9.4.3](#)).

Be careful when assembling the main bearing cover to the crankcase that the governor and camshaft gears mesh properly. If necessary, poke a thin rod through the gap between crankcase and cover to turn the governor gear slightly so that the teeth mesh.

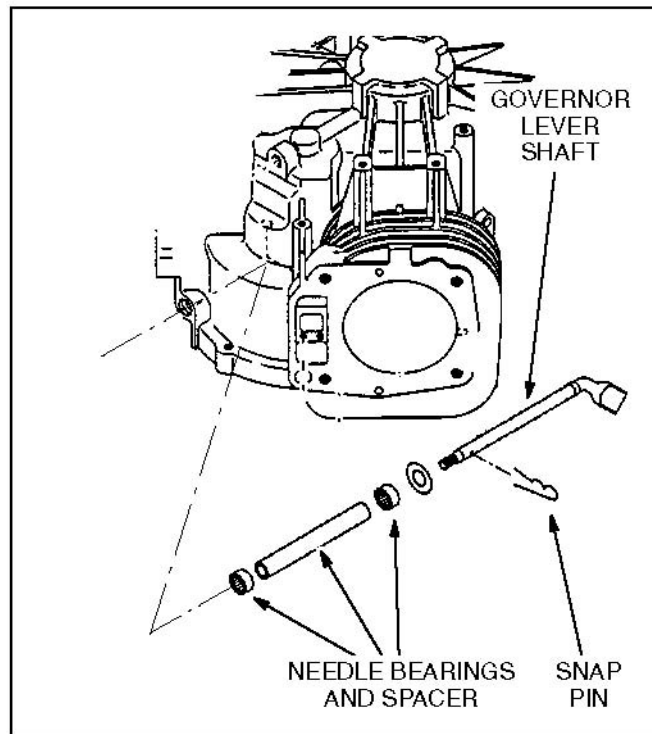

FIGURE 76. GOVERNOR LEVER

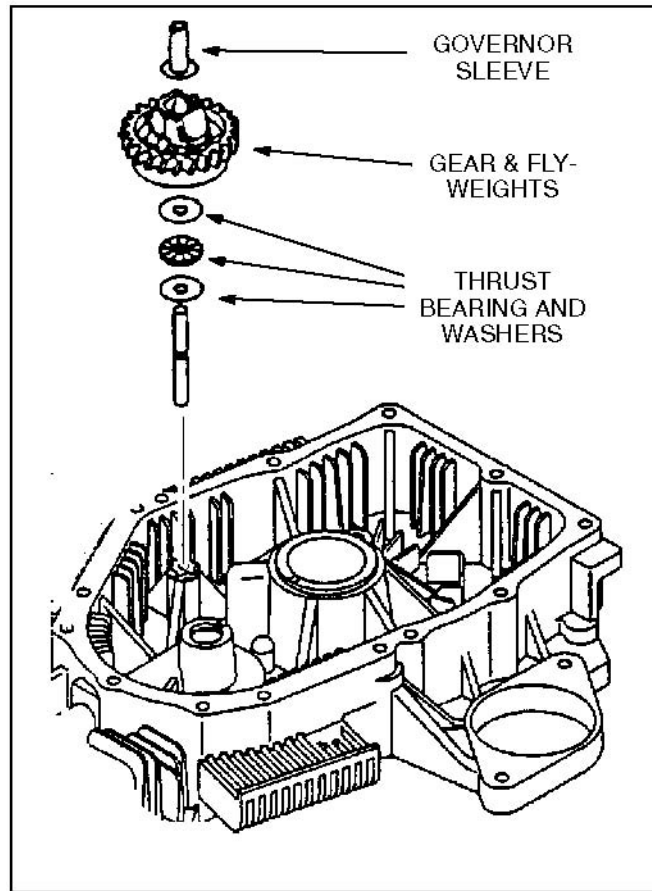
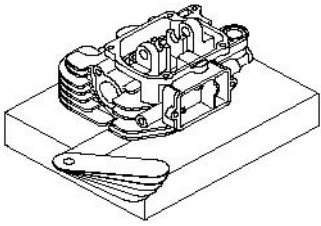
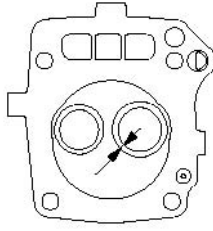
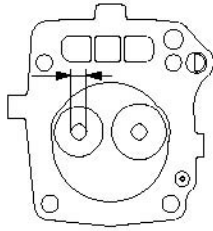
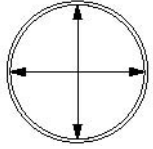
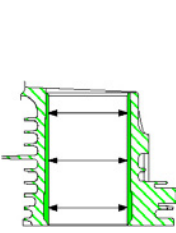
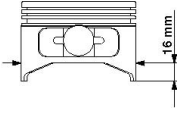
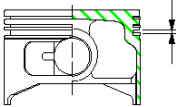
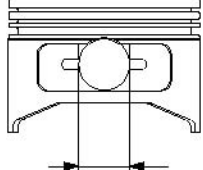
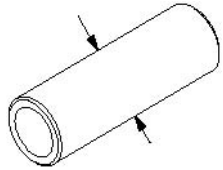
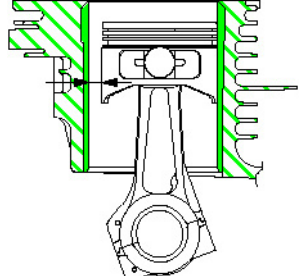
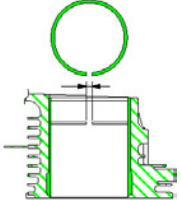
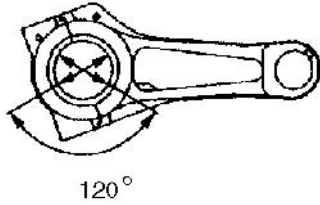
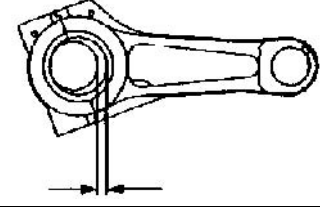
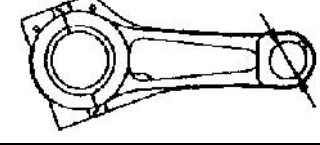
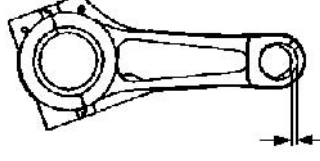
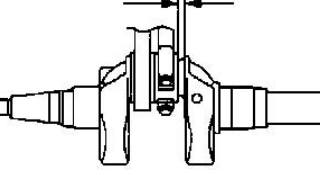
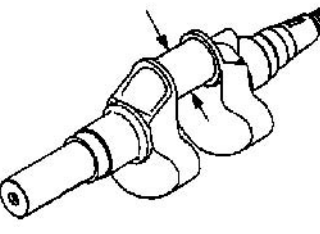
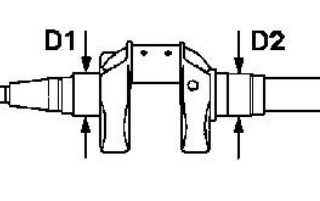

FIGURE 77. GOVERNOR GEAR

10.9 Dimensions and Clearances

Item	Description		Standard (in/mm)	Maximum (in/mm)
Cylinder Head	Flatness		0.002 or less (0.05 or less)	0.004 (0.1)
	Valve seat contact width	 Intake/ Exhaust	0.028 - 0.039 (0.7 - 1.0)	0.079 (2.0)
	Valve guide inside diameter		0.2376 - 0.2383 (6.035 - 6.053)	0.242 (6.15)
Cylinder	Inside diameter		STD	Rebore when the difference between the max. and min. of diameter reaches 0.004 (0.1)
	-----		1st Reboring	3.159 - 3.160 (80.250 - 80.269)
	-----		2nd Reboring	3.169 - 3.170 (80.500 - 80.519)
	-----		Roundness after rebores	0.004 (0.01)
	-----		Cylindricity after rebores	0.0006 (0.015)

Item	Description		Standard (in/mm)	Maximum (in/mm)
Piston	Piston size (at skirt in thrust direction) 	STD	3.148 - 3.149 (79.968 - 79.988)	3.145 (79.878)
		1st outer diameter	3.158 - 3.159 (80.218 - 80.238)	3.155 (80.128)
		2nd outer diameter	3.168 - 3.169 (80.468 - 80.488)	3.164 (80.378)
		Top	0.0002 - 0.0035 (0.05 - 0.09)	0.006 (0.15)
	Ring groove side clearance 	2nd	0.0012 - 0.0028 (0.03 - 0.07)	0.006 (0.15)
		Oil Ring	0.0022 - 0.0069 (0.057 - 0.175)	0.006 (0.15)
	Piston pin hole 		0.8262 - 0.8269 (20.989 - 21.002)	0.8281 (21.035)
	Piston pin outer diameter 		0.8264 - 0.8268 (20.991 - 21.000)	0.8251 (20.960)
	Clearance between piston and cylinder at skirt area 		0.0005 - 0.0020 (0.012 - 0.051)	0.0098 (0.25)
	Piston ring end gap 	Top 2nd	0.0079 - 0.0157 (0.2 - 0.4)	0.0591 (1.5)
Oil Ring		0.0079 - 0.0276 (0.2 - 0.7)	0.0591 (1.5)	

Item	Description	Standard (in/mm)	Maximum (in/mm)	
Connecting Rod	Large end inner diameter	 <p>120°</p>	1.5354 - 1.5361 (39.000 - 39.016)	1.5394 (39.100)
	Clearance between crankpin and inner diameter		0.0012 - 0.0024 (0.030 - 0.060)	0.0079 (0.2)
	Small end inner diameter		0.8272 - 0.8277 (21.010 - 21.023)	0.8299 (21.080)
	Clearance between piston pin and inner diameter		0.0004 - 0.0013 (0.010 - 0.032)	0.0047 (0.12)
	Large end side clearance		0.0039 - 0.0157 (0.1 - 0.4)	0.0394 (1.0)
Crankshaft	Crankpin outer diameter		1.5337 - 1.5343 (38.956 - 38.970)	1.5315 (38.90)
	Journal diameter		D1: 1.77102 - 1.77165 (44.984 - 45.000) D2: 1.77110 - 1.77154 (44.986 - 44.997)	-----
	End Play		0.005 - 0.012 (0.127 - 0.305)	-----

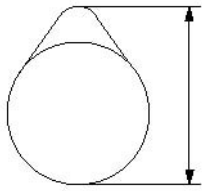
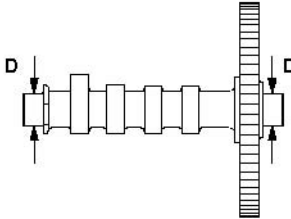
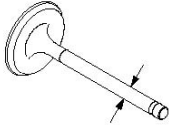
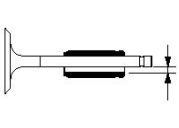
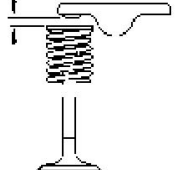
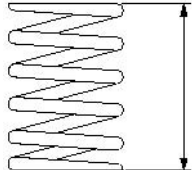
Item	Description			Standard (in/mm)	Maximum (in/mm)
Camshaft	Cam height (internal and external)			1.4213 - 1.4291 (36.1 - 36.3)	1.4154 (35.95)
	Journal outer diameter "D"			0.7861 - 0.7866 (19.967 - 19.980)	0.7854 (19.950)
Valve	Valve stem outer diameter		Intake	0.2350 - 0.2356 (5.970 - 5.985)	0.2303 (5.85)
			Exhaust	0.2346 - 0.2352 (5.960 - 5.975)	0.2303 (5.85)
	Clearance between valve stem and valve stem guide		Intake	0.0022 - 0.0033 (0.050 - 0.083)	0.0118 (0.30)
			Exhaust	0.0024 - 0.0037 (0.060 - 0.093)	0.0118 (0.30)
	Valve clearance		Intake/ Exhaust Measured Cold	0.0034 - 0.0045 (0.085 - 0.115)	
Valve Spring	Free length			1.5551 (39.5)	-----

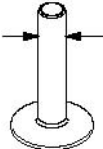
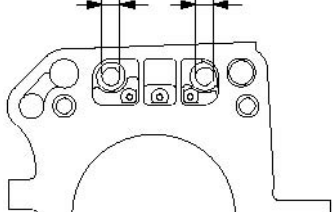
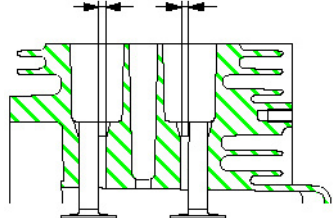
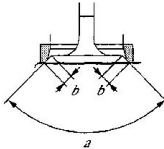
Item	Description		Standard (in/mm)	Maximum (in/mm)	
Tappet	Outer stem diameter		0.03528 - 0.3533 (8.960 - 8.975)	0.3516 (8.93)	
	Inner guide diameter		0.3543 - 0.3549 (9.00 - 9.015)	0.3575 (9.08)	
	Tappet guide clearance		0.0010 - 0.0022 (0.025 - 0.055)	0.0059 (0.15)	
Valve Seat Angle	-----		Cut angle	90°	-----
			Contact width	0.028 - 0.039 (0.7 - 1.0)	0.079 (2.0)

This page is intentionally blank.

11 Hydraulic Pump

The optional hydraulic pump, when provided, is mounted atop the engine ([Figure 78](#)). See the Specifications section regarding hose fittings, fluid specifications and inlet conditions.

11.1 Installing the Hydraulic Pump

NOTICE

Running the generator set without oil in the hydraulic pump will destroy the pump.

NOTICE

The slightest amount of dirt in a hydraulic system can damage precisely machined internal components. Keep dirt out by:

- Thoroughly cleaning the outside of a fitting or cap before disconnecting or removing it
- Keeping all openings in components and hoses capped with proper JIC caps until just before making connections
- Thoroughly flushing hoses before connecting
- Regularly replacing the oil filter
- Never reuse hydraulic fluid that has been drained from a system

1. When installing the pump, apply molybdenum disulfide paste or equivalent to the shaft spline.
2. Torque the two flange screws to 20 lb-ft (26 Nm).
3. Make sure to connect the hydraulic pump to the hydraulic system and fill it with oil **before starting the generator set**.

11.2 Connecting Hydraulic Hoses

⚠ WARNING

The high pressure spray from a leak or fitting in a hydraulic line can penetrate the skin, leading to possible blood poisoning.

- *Wear safety glasses.*
- *Shut down the generator set before loosening or tightening fittings.*
- *Do not delay getting proper medical attention if exposed to high pressure oil spray.*

NOTICE

Hoses shrink slightly in length and expand slightly in diameter under pressure.

When connecting hoses and starting up the system:

- Make sure there is enough slack in the connected hoses to prevent strain due to movement of the pump.
- Support, restrain and protect hydraulic hose as necessary to prevent chaffing.

- Do not bend hose tighter than the hose manufacturer recommends.
- Use wide-sweep 90° fittings.
- Always use two wrenches when tightening hydraulic fittings.
- Install an SAE Class 4 filter (10 micron) in the system.
- Make sure the system oil reservoir is above the pump and the hose from the pump slopes up to the reservoir.
- To fill the pump, first fill the reservoir and crank the engine with the spark plug cables disconnected from the spark plugs to prevent the engine from starting. Replenish oil in the reservoir as necessary.
- The installed system must not cause pump inlet conditions to exceed those in the Specifications section.

⚠ CAUTION

Continuing to run or load a noisy pump can destroy it. Purge the air before continuing.

- The hydraulic system has air in it as long as there continues to be sharp metallic noise. Run the generator set for a few seconds at a time until all air has been purged.

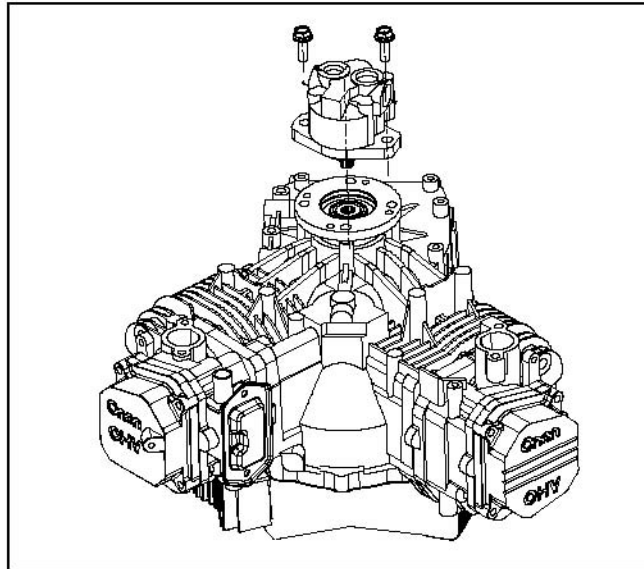

FIGURE 78. HYDRAULIC PUMP

12 Troubleshooting Overview

WARNING

Hot engine parts can cause severe burns. Always allow the engine time to cool before performing any maintenance or service.

WARNING

When equipped with an integral or add-on Automatic Generator Starting System (AGS) control, exhaust carbon monoxide (CO), electric shock, and moving parts hazards are possible due to unexpected starting. Turn off AGS whenever performing maintenance or service, when the vehicle is stored between uses, is awaiting service, or is parked in a garage or other confined area.

The fault codes are listed in numerical order along with step-by-step corrective actions. Refer to the appropriate wiring diagram and harness drawings beginning on [Appendix A](#).

Note the following:

- Maintaining engine oil level, keeping battery connections clean and tight, watching the fuel gauge, not overloading the generator set, etc. will prevent most shutdowns.
- When the generator set and vehicle engine share a common fuel tank the fuel dip tubes are usually arranged so that the generator set will run out of fuel first. Marking the generator set empty point on the fuel gauge will make it easier to tell when to stop the generator set before running it out of fuel.

12.1 Fault Codes

The generator set controller provides extensive diagnostics by causing the status indicator light on the control switch to blink in a coded fashion. Following a fault shutdown, the indicator light will repeatedly blink 1, 2, 3, or 4 blinks at a time.

- **1 Blink:** indicates shutdown due to high engine coolant temperatures. For example:

blink-long pause-blink-long pause-repeat

- **2 Blinks:** indicates a low oil pressure fault. For example:

blink-blink-long pause-blink-blink-long pause-repeat

- **3 Blinks:** indicates a service fault. For example:

blink-blink-blink-long pause-repeat

Press STOP/Prime once more to cause the two-digit, second-level fault to blink. (Pressing STOP/Prime again will stop the blinking.) The two-digit code consists of 1, 2, 3, 4, or 5 blinks, a short pause, and then 1 to 9 blinks. The first set of blinks represents the tens digit and the second set of blinks represents the ones digit of the fault code number. The second set of blinks for the ones digit will blink slightly slower than the tens digit. For example, Fault Code No.36 appears as:

blink-blink-blink-short pause-blink-blink-blink-blink-blink-blink-long pause-repeat

- **4 Blinks:** indicates that cranking exceeded 30 seconds without the engine starting. For example:

blink-blink-blink-blink-long pause-repeat

- Flashing at high frequency - The generator set is operating in Engine Run Only (ERO) mode. AC output is disabled.

NOTICE

Shutdown code Nos. 1, 2, 3 and 4 are first level faults. Avoid interpreting them as second-level shutdown code Nos. 11, 22, 33 and 44, which have not been assigned as shutdown codes.

NOTICE

Generator sets equipped with an AutoGen Start or AGS feature may experience shutdowns with no Fault Codes. This is because the AutoGen Start control is sending the generator set control a signal that is sensed as a normal shutdown signal.

Because different fault logics are used on different products, refer to the appropriate product's service manual to translate the blink code shutdown fault. Each fault will have a description of the shutdown reason and a list of step by step corrective actions.

Restoring Fault Code Blinking: The fault code stops blinking after five minutes (15 minutes, Series HGJAA and HGJAD). Press **Stop** three times within five seconds to restore blinking.

NOTICE

The last fault logged will blink even after the condition that caused the shutdown has been corrected.

12.2 Generator Set Starts or Stops Without Command - No Fault Code

⚠ WARNING

Some generator set service procedures present hazards that can result in severe personal injury or death. Only trained and experienced persons with knowledge of fuels, electricity, and machinery hazards should perform generator set service. See Safety Precautions.

Logic: To start or stop - control receives ground at start or stop input on control, DC voltage drops below 9V and controller de-energizes (shuts down in sleep mode)

Possible Cause: Low battery voltage, shorted harness connection, faulty start/stop switch, Auto Gen Start (AGS) is enabled

Diagnosis and Repair:

1. Check last fault and record.
2. Measure battery voltage at battery and generator set.
3. Inspect battery connections and cables for cleanliness, tightness and damage: clean, tighten and repair connections and cables as necessary.
4. Check electrolyte level and hydrometer reading in maintenance type batteries: replace electrolyte and recharge or replace battery as necessary.
5. Disconnect generator set control P1 connector, verify P1 pins are fully inserted and inspect pin condition per PSB-676: insert, repair or replace pins as necessary.
6. Reconnect P1 connector and test run generator set for symptom: repair or replace pins in connector as necessary.

7. Measure battery voltage at generator set while attempting to start from local or remote switch: recharge or replace battery if voltage drops below 9 VDC, test and service generator set battery charger if so equipped, increase battery cable size or run parallel cables.
8. Measure battery voltage and check for charger increase while generator set is running.
9. Measure for continuity change across start/stop switch between neutral and start position and neutral and stop position at switches and at connector P1: reconnect or repair connections, replace switches as necessary.
10. Measure for continuity from start and stop inputs to ground at switches and at connector P1: Repair or replace damaged harness.
11. Determine if AGS is installed and enabled (AGS will command start and stop based on its own settings): disable AGS or explain AGS function to customer (see PSB-666).

12.3 Generator Set Shuts Down With Fault Code - No Cause Determined

WARNING

Some generator set service procedures present hazards that can result in severe personal injury or death. Only trained and experienced persons with knowledge of fuels, electricity, and machinery hazards should perform generator set service. See the Safety Precautions section.

Logic: After performing all of the resistance checks, the user is still unable to come up with a root cause. When the set shuts down on a fault code, and the user restarts the generator set within one minute, the generator set will run but the majority of the faults are bypassed and there is no AC output.

Possible Cause: The generator set has software with Engine Run Only (ERO) functions. The generator set requires the control to operate the engine and a by-pass tester cannot be used to perform additional tests like a dynamic stator/rotor test.

Diagnosis and Repair:

NOTICE

The voltage regulator portion of the control is turned off so there will be no AC output when the generator set is operating in ERO mode.

1. Put 12 or 24 VDC to the brushes. Check the AC output at the Q windings and the main windings.
2. Using the chart below, determine the appropriate AC output voltages with the corresponding DC input to the field.

NOTICE

A flying short/open test may also be performed on the rotor when the set is in the ERO mode, by verifying the circuit between the brushes and ground is an open circuit.

TABLE 14. APPROPRIATE AC OUTPUT VOLTAGES

Field	Q1/Q2	L1/L0
12 VDC	56 VAC	30 VAC
24 VDC	98 VAC	53 VAC

NOTICE

Output readings may vary as much as +/- 10%.

12.4 No Response - Status Indicator Light Dead

⚠ WARNING

Some generator set service procedures present hazards that can result in severe personal injury or death. Only trained and experienced persons with knowledge of fuels, electricity, and machinery hazards should perform generator set service. See the Safety Precautions section.

Logic: To start - control receives ground via start/stop switch to start or stop input on control

Possible Cause: Low/no battery voltage, poor battery connection, faulty battery, open harness connection, faulty start/stop switch, faulty LED

Diagnosis and Repair:

1. Measure battery voltage at battery, at the generator set and at Connector P1. Reconnect, clean, repair and replace connections as necessary.
2. Measure battery voltage at generator set while attempting to start or prime from local or remote switch.
 - Recharge or replace the battery if the voltage drops below 9 VDC.
 - Test and service the generator set battery charger if so equipped.
 - Increase the battery cable size or run parallel cables.
3. Measure for a continuity change across the start/stop switch between the neutral and start position and between the neutral and stop position at the switches and at Connector P1. Reconnect or repair connections. Replace switches as necessary.
4. Test switches LED by energizing with 12 VDC. Replace the switches as necessary.
5. Disconnect generator set control Connector P1. Verify the P1 pins are fully inserted. Inspect pin condition per PSB-676. Insert, repair or replace pins as necessary.
6. Reconnect Connector P1.
7. Test run generator set for start and prime operation. Replace the control as necessary.

12.5 Starting Batteries Run Down

⚠ WARNING

Some generator set service procedures present hazards that can result in severe personal injury or death. Only trained and experienced persons with knowledge of fuels, electricity, and machinery hazards should perform generator set service. See the Safety Precautions section.

Logic: Low/no battery voltage

Possible Cause: Battery connections, battery, charging system, excessive cranking, excessive priming

Diagnosis and Repair:

1. Measure battery voltage at the battery and alternator.
2. Inspect battery connections and cables for cleanliness, tightness and damage. Clean, tighten and repair connections and cables as necessary.
3. Check the electrolyte level and hydrometer reading in maintenance type batteries. Replace the electrolyte, recharge the battery, or replace the battery as necessary.
4. Verify the battery charger is on and check operation.
5. Measure battery voltage. Check for charging increase while generator set is running.
6. Check the last fault and record. Troubleshoot as necessary.
7. Disconnect generator set control Connector P1.
8. Inspect pin condition per PSB-676, found in *Product Support Bulletins (603 thru 680)* on QSOL. Insert, repair, or replace pins as necessary.
9. Reconnect Connector P1.
10. Test run the generator set for fault occurrence. Repair or replace pins in the connector as necessary.
11. Measure for continuity change across start/stop switch between neutral and stop position at switches and Connector P1. Replace switches as necessary or disconnect the external stop device if so equipped.
12. Measure for voltage at fuel pump while the generator set is not running or being primed. Replace the control as necessary.

12.6 Starter Engages - Disengages

 **WARNING**

Some generator set service procedures present hazards that can result in severe personal injury or death. Only trained and experienced persons with knowledge of fuels, electricity, and machinery hazards should perform generator set service. See Safety Precautions.

Logic: Cranking voltage dips below 6 VDC: microprocessor aborts start attempt

Possible Cause: Battery connections, battery, charging system, start/stop switches, engine compression

Diagnosis and Repair:

1. Measure battery voltage at battery and generator set.
2. Inspect battery connections and cables for cleanliness, tightness and damage: clean, tighten and repair connections and cables as necessary.
3. Check electrolyte level and hydrometer reading in maintenance type batteries: replace electrolyte and recharge or replace battery as necessary.
4. Disconnect generator set control P1 connector, verify P1 pins are fully inserted and inspect pin condition per PSB-676: insert, repair or replace pins as necessary.
5. Reconnect P1 connector and test run generator set for fault occurrence: repair or replace pins in connector as necessary.

6. Measure battery voltage at generator set while attempting to start from local or remote switch: recharge or replace battery if voltage drops below 9 VDC, test and service generator set battery charger if so equipped, increase battery cable size or run parallel cables.
7. Measure battery voltage and check for charger increase while generator set is running.

12.7 No AC Power - Generator Set Running Status LED on Steady or Flashing Rapidly

WARNING

Some generator set service procedures present hazards that can result in severe personal injury or death. Only trained and experienced persons with knowledge of fuels, electricity, and machinery hazards should perform generator set service. See the Specifications section.

Logic: The generator set control is in normal or Engine Run Only (ERO) mode.

Possible Cause: Circuit breakers, ERO mode due to faulty generator

Diagnosis and Repair:

- If the Status light is on:
 1. Measure the AC output at the generator set circuit breaker.
 2. Reset or turn on the generator set circuit breaker, and diagnose faulty loads as necessary
- If the Status light is rapidly flashing and the generator set is in ERO mode:
 1. Remove Connector P1 from the control and re-install it.
 2. Start the generator set. Inspect, repair or replace Connector P1 pins as necessary.
 3. While running in ERO mode, externally excite field with 12 VDC or 24 VDC. Measure the main and quadrature winding AC output.
 4. Measure field, quadrature and main winding resistance. Clean slip rings, replace brushes, repair harness and replace rotor or stator as necessary.
 5. Measure field, quadrature and main winding resistance to ground. Clean slip rings, replace brushes, repair harness and replace rotor or stator as necessary.
 6. Measure field, quadrature and main winding resistance to each other. Clean slip rings, replace brushes, repair harness and replace rotor or stator as necessary.
 7. Check brush alignment per CPGF-S-00000258-0.

12.8 Generator Set Cranks But Does Not Start - No Fault Code

WARNING

Some generator set service procedures present hazards that can result in severe personal injury or death. Only trained and experienced persons with knowledge of fuels, electricity, and machinery hazards should perform generator set service. See Safety Precautions.

Logic: Fault codes are based on time lapse between events

Possible Cause: Not holding start switch long enough to cause fault

Diagnosis and Repair:

1. Check and record last fault code.
2. Measure battery voltage at battery and generator set; recharge or replace battery as necessary.
3. Crank generator set and hold switch until control stops cranking and displays fault code (approximately 30 seconds): troubleshoot fault code and reference last fault code recorded above if necessary.

12.9 Generator Set Runs But Stops When Switch Is Released - No Fault Code

⚠ WARNING

Some generator set service procedures present hazards that can result in severe personal injury or death. Only trained and experienced persons with knowledge of fuels, electricity, and machinery hazards should perform generator set service. See Safety Precautions.

Logic: Fault codes are based on time lapse between events

Possible Cause: Not holding start switch long enough to cause fault

Diagnosis and Repair:

1. Check and record last fault code.
2. Start generator set and hold switch until control shuts down and displays fault code (approximately 30 seconds): troubleshoot fault code and reference last fault code recorded above if necessary.

12.10 Engine Hard to Start - No Fault Code

Possible Cause:

1. Faulty EVAP check valves
2. Leak in the EVAP system lines or connections

Diagnosis and Repair:

1. Faulty EVAP check valves
 - a. Check valves can fail, causing vapors to leak. A gasoline odor will be noticed. Check valves can also be installed backwards from the factory.
 - b. Make sure check valves are installed in the correct direction (the arrow should point toward the manifold. The green side of the valve should point toward the manifold and the cream side should point toward the tank).
 - c. If there still appears to be a check valve issue, replace check valves.
2. Leak in the EVAP system lines or connections
 - a. A leak can occur at any point along the EVAP line; e.g., a line is missing or broken, there is a leak in the connection, etc. A leak results in air, rather than gasoline vapor, being forced into the intake manifold.
 - b. Make sure the EVAP line is connected to the intake manifold. This line can come loose during shipping.
 - c. In non-EVAP applications, ensure the plug (part number 0718-1017) is installed in the intake manifold port.

- d. Disconnect EVAP line at each of the following points and plug to engine. If the engine runs as normal when any one of the following points is plugged, then the leak is somewhere upstream from that point.
 - i. Disconnect at the intake manifold.
 - ii. Disconnect at the generator set enclosure.
 - iii. After the disconnection from the generator set enclosure, contact your OEM for further troubleshooting.

12.11 Engine Runs Lean, Rough, or Surges - No Fault Code

Possible Cause:

1. Faulty EVAP check valves
2. Leak in the EVAP system lines or connections

Diagnosis and Repair:

1. Faulty EVAP check valves
 - a. Check valves can fail, causing vapors to leak. A gasoline odor will be noticed. Check valves can also be installed backwards from the factory.
 - b. Make sure check valves are installed in the correct direction (the arrow should point toward the manifold. The green side of the valve should point toward the manifold and the cream side should point toward the tank).
 - c. If there still appears to be a check valve issue, replace check valves.
2. Leak in the EVAP system lines or connections
 - a. A leak can occur at any point along the EVAP line; e.g., a line is missing or broken, there is a leak in the connection, etc. A leak results in air, rather than gasoline vapor, being forced into the intake manifold.
 - b. Make sure the EVAP line is connected to the intake manifold. This line can come loose during shipping.
 - c. In non-EVAP applications, ensure the plug (part number 0718-1017) is installed in the intake manifold port.
 - d. Disconnect EVAP line at each of the following points and plug to engine. If the engine runs as normal when any one of the following points is plugged, then the leak is somewhere upstream from that point.
 - i. Disconnect at the intake manifold.
 - ii. Disconnect at the generator set enclosure.
 - iii. After the disconnection from the generator set enclosure, contact your OEM for further troubleshooting.

12.12 Low Oil Pressure Fault - Fault Code 2

WARNING

Some generator set service procedures present hazards that can result in severe personal injury or death. Only trained and experienced persons with knowledge of fuels, electricity, and machinery hazards should perform generator set service. See the Safety Precautions section.

Logic: Continuous ground at control for oil pressure input

NOTICE

The oil pressure switch is normally closed; it opens at 14.2 psi.

Possible Causes: Low oil pressure, low/high oil level, faulty switch, faulty oil pressure relief valve, fault oil pump

Diagnosis and Repair:

1. Verify that the last fault is FC 2:
 - If "Yes", continue diagnostics.
 - If "No", troubleshoot the actual last fault.
2. Measure the oil level. Add or drain oil as necessary.
3. Disconnect generator set control Connector P1.
4. Verify P1 pins are fully inserted.
5. Inspect pin condition per PSB-676, found in *Product Support Bulletins (603 thru 680)* on QSOL. Insert, repair or replace pins as necessary.
6. Reconnect the Connector P1.
7. Test run the generator set for fault occurrence. Repair or replace pins in the connector as necessary.
8. Measure continuity change across the start/stop switch between rest and under simulated pressure. Replace the switch as necessary.
9. Measure continuity between ground and P1-6. Repair or replace the harness as necessary.
10. Measure the oil pressure with a mechanical gauge. Repair or replace the relief valve and oil pump as necessary.

12.13 Service Check Fault - Fault Code 3

WARNING

Some generator set service procedures present hazards that can result in severe personal injury or death. Only trained and experienced persons with knowledge of fuels, electricity, and machinery hazards should perform generator set service. See the Safety Precautions section.

Logic: There is a single-digit fault that indicates a shutdown due to a two-digit fault.

Possible Cause: Any two-digit fault code

Diagnosis and Repair:

1. Verify that the last fault is FC 3:
 - If "Yes", continue the diagnosis.
 - If "No", troubleshoot the actual last fault.
2. While the LED is flashing three times, press stop once (1 second duration). Troubleshoot the two-digit fault code.

12.14 Overcrank - Fault Code 4

 **WARNING**

Some generator set service procedures present hazards that can result in severe personal injury or death. Only trained and experienced persons with knowledge of fuels, electricity, and machinery hazards should perform generator set service. See the Safety Precautions section.

Logic: The controller is unable to sense the generator set frequency after 30 seconds of holding the start switch.

Possible Cause: Faulty switch, faulty external start command, fuel supply, air fuel mixture, exhaust system, wire connections, starter, ignition system

Diagnosis and Repair:

1. Verify that the last fault is FC 4:
 - If "Yes", continue the diagnosis.
 - If "No", troubleshoot the actual last fault.
2. Measure battery voltage at the battery and the generator set. Recharge or replace the battery as necessary.
3. Measure for continuity change across the start/stop switch between the neutral and start position at the switches and Connector P1. Replace the switches as necessary or disconnect the external start device if so equipped.
4. Disconnect generator set control Connector P1.
5. Verify P1 pins are fully inserted.
6. Inspect pin condition per PSB-676, found in *Product Support Bulletins (603 thru 680)* on QSOL. Insert, repair or replace pins as necessary.
7. Reconnect Connector P1.
8. Test run the generator set for fault occurrence. Repair or replace pins in the connector as necessary.
9. Verify engine rotation manually. Repair engine damage as necessary.
10. Measure the DC voltage at the starter during a start attempt. Repair wire connections, and replace the start solenoid and starter as necessary.
11. Check air filter cleanliness. Replace the air filter as necessary.
12. Check for a blocked or damaged exhaust system. Repair or replace exhaust components as necessary.
13. **All gasoline models:**
 - a. Vapor lock may occur in high ambient temperatures: operate in ambients at less than 120 °F. Verify proper installation to prevent air recirculation. Correct as necessary.

-
- b. Measure steady DC voltage at the fuel pump while the generator set is cranking. Repair wiring as necessary.
 - c. Start the generator set on a shop fuel supply. Verify the tank level and fuel line condition in the vehicle.
14. **All gasoline carburetor models:**
- a. Verify the carburetor altitude setting. Re-adjust as necessary.
 - b. Verify choke operation, setting, linkage, vacuum pull off assembly, and sustain valve. Re-adjust, repair or replace as necessary.
 - c. Measure the fuel pump pressure/flow. Replace the fuel filter or fuel pump as necessary.
 - d. Inspect the carburetor butterfly for binding. Replace the carburetor as necessary.
15. **All gasoline EFI models:**
- a. Inspect the throttle body for binding or damage. Replace as necessary.
 - b. Measure the fuel pump pressure/flow. Replace fuel filter, pressure regulator, or fuel pump as necessary.
16. **All propane models:**
- a. Make sure the propane tanks are at least half-full to provide the proper vaporization rate when ambient temperatures are less than 40 °F vapor-withdrawal.
 - b. Use HD-5 grade propane. (Propane with more than 2.5% butane will not vaporize in ambients below 32 °F.)
 - c. Measure steady DC voltage at the fuel solenoid while the generator set is running. Repair wiring as necessary.
 - d. Verify a clear vent hose.
 - e. Run the generator set on shop fuel supply. Verify the tank level and fuel line condition in the vehicle.
 - f. Check the generator set fuel lines for damage. Replace the fuel line as required.
 - g. Measure the regulator lock off pressure.
17. Check the governor, actuator, linkage and spring for debris, damage and looseness. Re-adjust and repair as necessary.
18. Verify that the spark plug cables are secure on the spark plugs. Reconnect or replace as necessary.
19. Measure DC voltage from the ignition kill lead at greater than 1 VDC. Repair or replace the leads, pins, or magnetos as necessary.
20. Inspect the ignition kill leads in the harness and at Connector P1. Repair or replace lead, terminal, or pins as necessary.
21. Test the magnetos:
- a. Disconnect Connector P1.
 - b. Connect the positive (+) meter lead to chassis ground.
 - c. Measure continuity to negative lead at pin P1-4 and P1-5 or P1-15 and P1-20 based on model/spec and control card.
 - When measuring with the negative lead to the shut-off terminal and the positive lead to core, the kill terminal resistance should read between 1 Ohm and 20 Ohms. Replace the magneto if it does not.

- When measuring with the positive lead on the kill terminal and negative lead to the core, the kill terminal resistance should read higher than 500k Ohms. Replace the magneto if it does not.
22. Measure the spark plug gap. Set the gap or replace the spark plugs as necessary.
 23. Verify ignition spark condition.
 24. Inspect the spark plug lead and kill lead terminal at the magneto. Measure the magneto air gap. Replace terminals, set the gap, or replace magnetos as necessary.
 25. Measure field, quadrature and main winding resistance. Clean slip rings, replace brushes, repair harness, and replace the rotor or stator as necessary.
 26. Measure field, quadrature and main winding resistance to ground. Clean slip rings, replace brushes, repair harness, and replace the rotor or stator as necessary.
 27. Measure field, quadrature and main winding resistance to each other. Clean slip rings, replace brushes, repair the harness, and replace the rotor or stator as necessary.
 28. Check brush alignment per CPGF-S-00000258-0.

NOTICE

Dealers should contact their distributor for technical support; distributors should contact the factory for technical support.

12.15 Overvoltage - Fault Code 12

⚠ WARNING

Some generator set service procedures present hazards that can result in severe personal injury or death. Only trained and experienced persons with knowledge of fuels, electricity, and machinery hazards should perform generator set service. See the Safety Precautions section.

Logic:

- Instantaneous fault: AC voltage S1-S2 is greater than 150 VAC.
- Delayed fault: AC voltage S1-S2 is greater than 138 VAC, but less than 150 VAC for 3 continuous minutes.

Possible Causes: Generator set loads, inverter/charger, wire connections, AC sense transformer, windings

Diagnosis and Repair:

1. Verify that the last fault is FC 12:
 - If "Yes", continue the diagnosis.
 - If "No", troubleshoot the actual last fault.
2. Measure the AC voltage.
3. Measure the AC frequency while changing the engine RPM to determine if the frequency response matches the engine RPM response. Repair the damaged generator drive system as necessary.
4. Cycle loads to determine if a particular load causes a fault. Diagnose the faulty load as necessary.
5. Determine the inverter/charger battery charge rate (typical default is 80%). If adjustable, reduce to 30%.

6. Verify balanced loads in 120/240 VAC applications. Balance loads within 10% line-to-line as required.
7. Run the generator set in Engine Run Only (ERO) mode. Externally excite field F1-F2 with 12 VDC or 24 VDC. Measure the main and quadrature winding AC output. If the generator set does not keep running, measure the generator set frequency, quadrature winding voltage, and main winding voltage using Break-Out Tool 420-0603 and Instruction Sheet R1098.
8. Remove Connector P1 from the control and re-install it.
9. Start the generator set. Inspect, repair or replace Connector P1 pins as necessary.
10. Measure field, quadrature and main winding resistance. Clean slip rings, replace brushes, repair the harness, and replace the rotor or stator as necessary.
11. Measure field, quadrature and main winding resistance to ground. Clean slip rings, replace brushes, repair the harness, and replace the rotor or stator as necessary.
12. Measure field, quadrature and main winding resistance to each other. Clean slip rings, replace brushes, repair the harness, and replace the rotor or stator as necessary.
13. Check the brush alignment per CPGF-S-00000258-0.

NOTICE

Dealers should contact their distributor for technical support; distributors should contact the factory for technical support.

12.16 Undervoltage - Fault Code 13

⚠ WARNING

Some generator set service procedures present hazards that can result in severe personal injury or death. Only trained and experienced persons with knowledge of fuels, electricity, and machinery hazards should perform generator set service. See the Safety Precautions section.

Logic: AC voltage S1-S2 is less than 108 VAC for 5 continuous seconds.

Possible Causes: Generator set loads, inverter/charger, wire connections, generator drive system, windings, AC sense transformer, windings

Diagnosis and Repair:

1. Verify that the last fault is FC 13:
 - If "Yes", continue the diagnosis.
 - If "No", troubleshoot the actual last fault.
2. Measure the AC voltage.
3. Measure the AC voltage in and out of sense transformer (if so equipped). Repair the wire connection, and replace the sense transformer as necessary.
4. Measure the AC frequency while changing engine RPM to determine if frequency response matches engine RPM response. Repair the damaged generator drive system as necessary.
5. Cycle loads to determine if a particular load will cause a fault. Diagnose the faulty load as necessary.
6. Determine the battery charge rate (typical default is 80%). If adjustable, reduce to 30%.
7. Verify balanced loads in 120/240 VAC applications. Balance loads within 10% line-to-line as required.

8. Run the generator set in Engine Run Only (ERO) mode. Externally excite field F1-F2 with 12 VDC or 24 VDC. Measure the main and quadrature winding AC output. If the generator set does not keep running, measure the generator set frequency, and quadrature winding and main winding voltages using Break-Out Tool 420-0603 and Instruction Sheet R1098.
9. Remove Connector P1 from the control.
10. Re-install Connector P1.
11. Start the generator set. Inspect, repair or replace Connector P1 pins as necessary.
12. Measure the field, quadrature and main winding resistance. Clean the slip rings, replace brushes, repair the harness, and replace the rotor or stator as necessary.
13. Measure the field, quadrature and main winding resistance to ground. Clean the slip rings, replace brushes, repair the harness, and replace the rotor or stator as necessary.
14. Measure the field, quadrature and main winding resistance to each other. Clean the slip rings, replace brushes, repair the harness, and replace the rotor or stator as necessary.
15. Check the brush alignment per CPGF-S-00000258-0.

NOTICE

Dealers should contact their distributor for technical support; distributors should contact the factory for technical support.

12.17 Overfrequency - Fault Code 14

⚠ WARNING

Some generator set service procedures present hazards that can result in severe personal injury or death. Only trained and experienced persons with knowledge of fuels, electricity, and machinery hazards should perform generator set service. See the Safety Precautions section.

Logic:

- Instantaneous fault:
 - 60 Hz model: Frequency greater than 70 Hz
 - 50 Hz model: Frequency greater than 58 Hz
- Delayed fault:
 - 60 Hz model: Frequency greater than 66 Hz but less than 70 Hz for 6 consecutive seconds
 - 50 Hz model: Frequency greater than 55 Hz but less than 58 Hz for 6 consecutive seconds

Possible Causes: Generator set loads, inverter/charger, engine governor function, fuel supply, air fuel mixture, exhaust system, choke, demand regulator, carburetor, generator drive system, generator windings, ignition, wire connections

Diagnosis and Repair:

1. Verify that the last fault is FC 14:
 - If "Yes", continue the diagnosis.
 - If "No", troubleshoot the actual last fault.
2. Measure the AC current while running the generator set with vehicle loads. Identify faulty or short cycling loads.

3. Determine the battery charge rate (typical default is 80%). If adjustable, reduce to 30%.
4. Measure the generator set load capability with a shop load bank. Derate for altitude and temperature as necessary.
5. Measure the generator set frequency and droop while running.
6. Measure the AC frequency while changing engine RPM to determine if frequency response matches engine RPM response. Repair the damaged generator drive system as necessary.
7. Disconnect generator set control Connector P1.
8. Verify P1 pins are fully inserted. Inspect pin condition per PSB-676, found in *Product Support Bulletins (603 thru 680)* on QSOL. Insert, repair or replace pins as necessary.
9. Reconnect Connector P1.
10. Test run the generator set for fault occurrence. Repair or replace pins in the connector as necessary.
11. Check all grounds and neutral leads for looseness at battery, generator set, and inverter/converter. Run the generator set on a separate battery. Tighten or replace terminals and leads as necessary.
12. Check air filter cleanliness. Replace the air filter as necessary.
13. Check for a blocked or damaged exhaust system. Repair or replace exhaust components as necessary.
14. Verify P1-29 (if present) is not grounded on 60 Hz generator sets. Remove the lead termination, tape, and isolate.
15. Run the generator set in Engine Run Only (ERO) mode. Externally excite field F1-F2 with 12 VDC or 24 VDC. Measure the main and quadrature winding AC output. If the generator set does not keep running, measure the generator set frequency, and the quadrature winding and main winding voltages using Break-Out Tool 420-0603 and Instruction Sheet R1098.
16. **All gasoline models:**
 - a. Vapor lock may occur in high ambient temperatures. Operate in ambients at less than 120 °F. Verify proper installation to prevent air recirculation and correct as necessary.
 - b. Measure steady DC voltage at the fuel pump while the generator set is cranking. Repair the wiring as necessary.
 - c. Start the generator set on a shop fuel supply. Verify the tank level and fuel line condition in the vehicle.
17. **All gasoline carburetor models:**
 - a. Verify the carburetor altitude setting. Re-adjust as necessary.
 - b. Verify choke operation, setting, linkage, vacuum pull off assembly and sustain valve. Re-adjust, repair or replace as necessary.
 - c. Measure fuel pump pressure/flow. Replace the fuel filter or fuel pump as necessary.
 - d. Inspect the carburetor butterfly for binding. Replace the carburetor as necessary.
18. **All gasoline EFI models:**
 - a. Inspect the throttle body for binding or damage. Replace as necessary.
 - b. Measure the fuel pump pressure/flow. Replace the fuel filter, pressure regulator, or fuel pump as necessary.
19. **All propane models:**
 - a. Make sure the propane tanks are at least half-full to provide the proper vaporization rate when ambient temperatures are less than 40 °F vapor-withdrawal.

- b. Use HD-5 grade propane. (Propane with more than 2.5% butane will not vaporize in ambients below 32 °F.)
 - c. Measure steady DC voltage at the fuel solenoid while the generator set is running. Repair wiring as necessary.
 - d. Verify that the vent hose is clear.
 - e. Run the generator set on a shop fuel supply. Verify the tank level and fuel line condition in the vehicle.
 - f. Check the generator set fuel lines for damage. Replace the fuel line as required.
 - g. Measure the regulator lock off pressure.
20. Check the governor, actuator, linkage and spring for debris, damage and looseness. Re-adjust and repair as necessary.
 21. Measure field, quadrature, and main winding resistance. Clean slip rings, replace brushes, repair the harness, and replace the rotor or stator as necessary.
 22. Measure field, quadrature, and main winding resistance to ground. Clean slip rings, replace brushes, repair the harness, and replace the rotor or stator as necessary.
 23. Measure field, quadrature, and main winding resistance to each other. Clean slip rings, replace brushes, repair the harness, and replace the rotor or stator as necessary.
 24. Check the brush alignment per CPGF-S-00000258-0.
 25. Verify that the spark plug cables are secure on the spark plugs. Reconnect or replace as necessary.
 26. Inspect the ignition kill leads in the harness and at Connector P1. Repair or replace the lead, terminal, or pins as necessary.
 27. Test the magnetos:
 - a. Disconnect Connector P1.
 - b. Connect the positive (+) meter lead to chassis ground.
 - c. Measure continuity to the negative lead at pin P1-4 and P1-5 or P1-15 and P1-20, based on model/spec and control card.
 - d. Replace the magnetos as necessary.
 - When measuring with the negative lead to the shut-off terminal and the positive lead to core, the kill terminal resistance should read between 1 Ohm and 20 Ohms. Replace the magneto if it does not.
 - When measuring with the positive lead on the kill terminal and negative lead to the core, the kill terminal resistance should read higher than 500k Ohms. Replace the magneto if it does not.
 28. Measure the spark plug gap. Set the gap or replace spark plugs as necessary.
 29. Verify ignition spark condition.
 30. Inspect the spark plug cables, and kill lead terminal at the magneto. Measure the magneto air gap. Replace terminals, set the gap, or replace the magnetos as necessary.
 31. Measure the temperature of air intake and temperature rise across the generator set. Remove blockage or prevent air recirculation.

NOTICE

Dealers should contact their distributor for technical support; distributors should contact the factory for technical support.

12.18 Underfrequency - Fault Code 15

WARNING

Some generator set service procedures present hazards that can result in severe personal injury or death. Only trained and experienced persons with knowledge of fuels, electricity, and machinery hazards should perform generator set service. See the Safety Precautions section.

Logic:

- 60 Hz carburetor models: Frequency less than 54 Hz for 30 continuous seconds
- EFI models: Frequency less than 54 Hz for 60 Hz (45 Hz for 50 Hz) models for 8 continuous seconds

Possible Causes: Generator set loads, inverter/charger, engine governor function, fuel supply, air fuel mixture, exhaust system, choke, demand regulator, carburetor, generator drive system, generator windings, ignition, wire connections

Diagnosis and Repair:

1. Verify that the last fault is FC 15:
 - If "Yes", continue the diagnosis.
 - If "No", troubleshoot the actual last fault.
2. Measure AC current while running the generator set with vehicle loads. Identify faulty or short cycling loads.
3. Determine the battery charge rate (typical default is 80%). If adjustable, reduce to 30%.
4. Measure the generator set load capability with a shop load bank (derate for altitude and temperature as necessary).
5. Measure the generator set frequency and droop while running.
6. Measure the AC frequency while changing the engine RPM to determine if the frequency response matches the engine RPM response. Repair the damaged generator drive system as necessary.
7. Disconnect generator set control Connector P1.
8. Inspect pin condition per PSB-676, found in *Product Support Bulletins (603 thru 680)* on QSOL. Insert, repair or replace pins as necessary.
9. Reconnect Connector P1.
10. Test run the generator set for fault occurrence. Repair or replace pins in connector as necessary.
11. Check air filter cleanliness. Replace the air filter as necessary.
12. Check for a blocked or damaged exhaust system. Repair or replace exhaust components as necessary.
13. Run the generator set in Engine Run Only (ERO) mode. Externally excite field with 12 VDC or 24 VDC. Measure main and quadrature winding AC output. If the generator set does not keep running, measure the generator set frequency, quadrature winding voltages, and main winding voltages using Break-Out Tool 420-0603 and Instruction Sheet R1098.
14. **All gasoline models:**
 - a. Vapor lock may occur in high ambient temperatures. Operate in ambients at less than 120 °F. Verify proper installation to prevent air recirculation. Correct as necessary.
 - b. Measure steady DC voltage at the fuel pump while the generator set is cranking. Repair wiring as necessary.

-
- c. Start the generator set on a shop fuel supply. Verify the tank level and fuel line condition in the vehicle.
15. **All gasoline carburetor models:**
 - a. Verify the carburetor altitude setting. Re-adjust as necessary.
 - b. Verify the choke operation, setting, linkage, vacuum pull off assembly, and sustain valve. Re-adjust, repair or replace as necessary.
 - c. Measure the fuel pump pressure/flow. Replace the fuel filter or fuel pump as necessary.
 - d. Inspect the carburetor butterfly for binding. Replace the carburetor as necessary.
 16. **All gasoline EFI models:**
 - a. Inspect the throttle body for binding or damage. Replace as necessary.
 - b. Measure the fuel pump pressure/flow. Replace the fuel filter, pressure regulator, or fuel pump as necessary.
 17. **All propane models:**
 - a. Make sure the propane tanks are at least half-full to provide the proper vaporization rate when ambient temperatures are less than 40 °F vapor-withdrawal.
 - b. Use HD-5 grade propane. (Propane having more than 2.5% butane will not vaporize in ambients below 32 °F.)
 - c. Measure steady DC voltage at the fuel solenoid while the generator set is running. Repair the wiring as necessary.
 - d. Verify a clear vent hose.
 - e. Run the generator set on a shop fuel supply. Verify tank level and fuel line condition in vehicle.
 - f. Check the generator set fuel lines for damage. Replace the fuel line as required.
 - g. Measure regulator lock off pressure.
 18. Check the governor, actuator, linkage, and spring for debris, damage, and looseness. Re-adjust and repair as necessary.
 19. Measure field, quadrature, and main winding resistance. Clean slip rings, replace brushes, repair the harness, and replace the rotor or stator as necessary.
 20. Measure field, quadrature, and main winding resistance to ground. Clean slip rings, replace brushes, repair the harness, and replace the rotor or stator as necessary.
 21. Measure field, quadrature, and main winding resistance to each other. Clean slip rings, replace brushes, repair the harness, and replace the rotor or stator as necessary.
 22. Check brush alignment per CPGF-S-00000258-0.
 23. Verify that the spark plug cables are secure on the spark plugs. Reconnect or replace as necessary.
 24. Inspect the ignition kill leads in the harness and at Connector P1. Repair or replace the lead, terminal, or pins as necessary.
 25. Test the magnetos:
 - a. Disconnect Connector P1.
 - b. Connect the positive (+) meter lead to chassis ground.
-

- c. Measure continuity to the negative lead at pin P1-4 and P1-5 or P1-15 and P1-20 based on model/spec and control card.
- When measuring with the negative lead to the shut-off terminal and the positive lead to core, the kill terminal resistance should read between 1 Ohm and 20 Ohms. Replace the magneto if it does not.
 - When measuring with the positive lead on the kill terminal and negative lead to the core, the kill terminal resistance should read higher than 500k Ohms. Replace the magneto if it does not.
26. Measure the spark plug gap. Set the gap or replace the spark plugs as necessary.
27. Verify ignition spark condition.
28. Inspect the spark plug lead and the kill lead terminal at the magneto. Measure the magneto air gap. Replace terminals, set the gap, or replace magnetos as necessary.
29. Measure temperature of the air intake and temperature rise across generator set. Remove blockage or prevent air recirculation.

NOTICE

Dealers should contact their distributor for technical support; distributors should contact the factory for technical support.

12.19 Fuel Pump Fault - Fault Code 17

⚠ WARNING

Some generator set service procedures present hazards that can result in severe personal injury or death. Only trained and experienced persons with knowledge of fuels, electricity, and machinery hazards should perform generator set service. See the Safety Precautions section .

Logic: Only active prior to 2001: Open fuel pump circuit at control

Possible Causes: Wire connections, harness leads, faulty fuel pump

Diagnosis and Repair:

1. Verify that the last fault is FC 17:
 - If "Yes", continue the diagnosis.
 - If "No", troubleshoot the actual last fault.
2. Verify fuel pump operation in prime mode. If pump operates, the fault condition has been cleared. Verify harness connections.
3. *HGJAA, HGJAD models only:* Check continuity across fuse F1.
4. Disconnect generator set control Connector P1.
5. Inspect pin condition per PSB-676, found in *Product Support Bulletins (603 thru 680)* on QSOL. Insert, repair, or replace pins as necessary.
6. Reconnect Connector P1.
7. Prime the generator set to verify pump operation. Test run the generator set for fault occurrence.
8. Measure continuity between E2 fuel pump leads. Replace terminals or fuel pump as necessary.

9. Measure voltage between fuel pump E2 + and ground while priming. Replace the terminals, harness leads, or control as necessary.

12.20 Governor Actuator (EFI Only) - Fault Code 19

WARNING

Some generator set service procedures present hazards that can result in severe personal injury or death. Only trained and experienced persons with knowledge of fuels, electricity, and machinery hazards should perform generator set service. See the Safety Precautions section.

Logic: Shorted or open connection between governor leads after pressing start

Possible Causes: Wire connections, P1-17, governor actuator

Diagnosis and Repair:

1. Verify that the last fault is FC 19:
 - If "Yes", continue the diagnosis.
 - If "No", troubleshoot the actual last fault.
2. Disconnect generator set control Connector P1.
3. Verify P1 pins are fully inserted.
4. Inspect pin condition per PSB-676, found in *Product Support Bulletins (603 thru 680)* on QSOL. Insert, repair or replace pins as necessary.
5. Reconnect Connector P1.
6. Test run the generator set for fault occurrence. Repair or replace pins in the connector as necessary.
7. *EFI models only:* If P1-17 is open to ground, ground the lead as required for carburetor configuration.
8. Verify actuator function by applying DC voltage to terminals. Replace the actuator as necessary.
9. Measure the resistance between actuator terminals. Repair or replace connections as necessary. Replace the governor actuator.
10. Measure continuity between P1-28 and the actuator lead. Repair or replace the terminals and leads as necessary.
11. Measure DC voltage at the actuator while starting. Replace the controller as necessary.

12.21 Governor Actuator Overload (EFI Only) - Fault Code 22

WARNING

Some generator set service procedures present hazards that can result in severe personal injury or death. Only trained and experienced persons with knowledge of fuels, electricity, and machinery hazards should perform generator set service. See the Safety Precautions section.

Logic: Only active prior to 2001: Maximum governor output (PWM) for 10 continuous seconds

Possible Causes: Generator set loads, inverter/charger, wire connections, fuel supply, air fuel mixture, exhaust system, governor actuator, ignition system

Diagnosis and Repair:

1. Verify that the last fault is FC 22:
 - If "Yes", continue the diagnosis.
 - If "No", troubleshoot the actual last fault.
2. Measure the AC current while running the generator set with vehicle loads. Identify faulty or short cycling loads, or reduce vehicle loads as necessary.
3. Determine the battery charge rate (typical default is 80%). If adjustable, reduce to 30%.
4. Measure generator set load capability with a shop load bank (derate for altitude and temperature as necessary).
5. Measure the AC frequency and droop while running.
6. Measure the AC frequency while changing engine RPM to determine if the frequency response matches the engine RPM response. Repair the damaged generator drive system as necessary.
7. Disconnect generator set control Connector P1.
8. Inspect pin condition per PSB-676, found in *Product Support Bulletins (603 thru 680)* on QSOL. Insert, repair or replace pins as necessary.
9. Reconnect Connector P1.
10. Test run the generator set for fault occurrence. Repair or replace pins in connector as necessary.
11. Check air filter cleanliness. Replace the air filter as necessary.
12. Check the intake manifold and gaskets for air leaks. Tighten fasteners, and replace gaskets and manifold as necessary.
13. Check for blocked or damaged exhaust system. Repair or replace exhaust components as necessary.
14. Measure fuel pump pressure/flow. Replace the fuel filter, pressure regulator, or fuel pump as necessary.
15. Verify actuator function by applying DC voltage to terminals. Replace the actuator as necessary.
16. Check the throttle body for binding. Inspect the spring for dirt and debris. Clean the spring, and replace the throttle body as necessary.
17. Verify that the spark plug cables are secure on the spark plugs. Reconnect or replace as necessary.
18. Inspect the ignition kill leads in the harness and at Connector P1. Repair or replace the lead, terminal, or pins as necessary.
19. Test the magnetos:
 - a. Disconnect Connector P1.
 - b. Connect the positive (+) meter lead to chassis ground.
 - c. Measure continuity to the negative lead at pin P1-4 and P1-5 or P1-15 and P1-20 based on model/spec and control card.
 - When measuring with the negative lead to the shut-off terminal and the positive lead to core, the kill terminal resistance should read between 1 Ohm and 20 Ohms. Replace the magneto if it does not.
 - When measuring with the positive lead on the kill terminal and negative lead to the core, the kill terminal resistance should read higher than 500k Ohms. Replace the magneto if it does not.
20. Measure the spark plug gap. Set the gap or replace the spark plugs as necessary.

21. Verify ignition spark condition.
22. Inspect the spark plug cables and kill lead terminal at the magneto. Measure the magneto air gap. Replace the terminals, set the gap, or replace magnetos as necessary.

NOTICE

Dealers should contact their distributor for technical support; distributors should contact the factory for technical support.

12.22 Oil Pressure Switch Fault - Fault Code 23

⚠ WARNING

Some genset service procedures present hazards that can result in severe personal injury or death. Only trained and experienced persons with knowledge of fuels, electricity, and machinery hazards should perform genset service. See Safety Precautions.

Logic: Only Active Prior to 2001 - Continuous open on oil pressure switch input before cranking

Possible Causes: Wire connections, faulty switch

Diagnosis & Repair:

1. Verify that Last Fault is FC 23: Yes, continue diagnosis; No, troubleshoot actual last fault.
2. Verify harness lead is connected to switch: repair or replace terminal as necessary.
3. Disconnect genset control P1 connector, verify P1 pins are fully inserted and inspect pin condition per: insert, repair or replace pins as necessary.
4. Reconnect P1 connector and test run genset for fault occurrence.
5. Measure continuity to ground at switch and through harness at P1 connector: replace switch, repair or replace harness as necessary.

12.23 Voltage Sense Lost - Fault Code 27

⚠ WARNING

Some generator set service procedures present hazards that can result in severe personal injury or death. Only trained and experienced persons with knowledge of fuels, electricity, and machinery hazards should perform generator set service. See the Safety Precautions section.

Logic: There is no sense voltage (0 VAC across S1-S2) for 1 continuous second after start disconnect.

Possible Causes: Generator set loads, inverter/charger, VAC sense transformer, engine governor function, fuel supply, choke, demand regulator, carburetor, generator windings, ignition, wire connections, temperature

Diagnosis and Repair:

1. Verify that the last fault is FC 27:
 - If "Yes", continue the diagnosis.
 - If "No", troubleshoot the actual last fault.
2. Measure AC voltage.

3. Determine the battery charge rate (typical default is 80%). If adjustable, reduce to 30%.
4. Disconnect generator set control Connector P1.
5. Verify P1 pins are fully inserted.
6. Inspect pin condition per PSB-676, found in *Product Support Bulletins (603 thru 680)* on QSOL. Insert, repair or replace pins as necessary.
7. Reconnect Connector P1.
8. Test run the generator set for fault occurrence. Repair or replace pins in the connector as necessary.
9. Check air filter cleanliness. Replace the air filter as necessary.
10. Check for a blocked or damaged exhaust system. Repair or replace exhaust components as necessary.
11. Run the generator set in Engine Run Only (ERO) mode. Externally excite field with 12 VDC or 24 VDC. Measure the main and quadrature winding AC output. If the generator set does not keep running, measure the generator set frequency, quadrature winding voltage, and main winding voltage using Break-Out Tool 420-0603 and Instruction Sheet R1098.
12. **All gasoline models:**
 - a. Vapor lock may occur in high ambient temperatures; operate in ambients lower than 120 °F. Verify proper installation to prevent air recirculation. Correct as necessary.
 - b. Measure steady DC voltage at the fuel pump while the generator set is cranking. Repair wiring as necessary.
 - c. Start the generator set on a shop fuel supply. Verify tank level and fuel line condition in vehicle.
13. **All gasoline Carburetor models:**
 - a. Verify the carburetor altitude setting. Re-adjust as necessary.
 - b. Verify choke operation, setting, linkage, vacuum pull off assembly, and sustain valve. Re-adjust, repair or replace as necessary.
 - c. Measure the fuel pump pressure/flow. Replace the fuel filter or fuel pump as necessary.
 - d. Inspect the carburetor butterfly for binding. Replace the carburetor as necessary.
14. **All gasoline EFI models:**
 - a. Inspect the throttle body for binding or damage. Replace as necessary.
 - b. Measure the fuel pump pressure/flow. Replace the fuel filter, pressure regulator, or fuel pump as necessary.
15. **All propane models:**
 - a. Make sure the propane tanks are at least half-full to provide the proper vaporization rate when ambient temperatures are less than 40 °F vapor-withdrawal.

Use HD-5 grade propane. (Propane with more than 2.5% butane will not vaporize in ambients below 32 °F.)
 - b. Measure steady DC voltage at the fuel solenoid while the generator set is running. Repair wiring as necessary.
 - c. Verify a clear vent hose.
 - d. Run the generator set on a shop fuel supply. Verify the tank level and fuel line condition in vehicle.
 - e. Check the generator set fuel lines for damage. Replace the fuel line as required.
 - f. Measure the regulator lock off pressure.

16. Check the governor, actuator, linkage and spring for debris, damage and looseness. Re-adjust and repair as necessary.
17. Measure field, quadrature, and main winding resistance. Clean slip rings, replace brushes, repair the harness, and replace the rotor or stator as necessary.
18. Measure field, quadrature, and main winding resistance to ground. Clean slip rings, replace brushes, repair the harness, and replace the rotor or stator as necessary.
19. Measure field, quadrature, and main winding resistance to each other. Clean slip rings, replace brushes, repair the harness, and replace the rotor or stator as necessary.
20. Check the brush alignment.
21. Verify that the spark plug cables are secure on the spark plugs. Reconnect or replace as necessary.
22. Inspect the ignition kill leads in the harness and at Connector P1. Repair or replace the lead, terminal, or pins as necessary.
23. Test the magnetos:
 - a. Disconnect Connector P1.
 - b. Connect the positive (+) meter lead to chassis ground.
 - c. Measure continuity to the negative lead at pin P1-4 and P1-5 or P1-15 and P1-20 based on model/spec and control card.
 - When measuring with the negative lead to the shut-off terminal and the positive lead to core, the kill terminal resistance should read between 1 Ohm and 20 Ohms. Replace the magneto as necessary.
 - When measuring with the positive lead on the kill terminal and negative lead to the core, the kill terminal resistance should read higher than 500k Ohms. Replace the magneto as necessary.
24. Measure the spark plug gap. Set the gap or replace the spark plugs as necessary.
25. Verify ignition spark condition.
26. Inspect the spark plug lead and the kill lead terminal at the magneto. Measure the magneto air gap. Replace terminals, set the gap, or replace magnetos as necessary.
27. Measure the temperature of air intake and temperature rise across the generator set. Remove blockage or prevent air recirculation.

NOTICE

Dealers should contact their distributor for technical support; distributors should contact the factory for technical support.

12.24 High Battery Voltage - Fault Code 29

⚠ WARNING

Some generator set service procedures present hazards that can result in severe personal injury or death. Only trained and experienced persons with knowledge of fuels, electricity, and machinery hazards should perform generator set service. See the Safety Precautions section.

Logic: The DC voltage to the controller is greater than 19 VDC when pressing start or stop.

Possible Causes: Incorrect battery configuration, wire damage, faulty charger, control

Diagnosis and Repair:

1. Verify that the last fault is FC 29:
 - If "Yes", continue the diagnosis.
 - If "No", troubleshoot the actual last fault.
2. Measure the DC voltage at the battery, generator set, and Connector P1. Reconnect the battery or repair wiring as necessary.
3. Measure the DC voltage with the battery charger on. Reduce the boost charge rate or diagnose faulty charger as necessary.
4. If the generator set shares batteries with a propulsion engine, check for a fault using a shop battery (a voltage spike may cause a fault). Diagnose the fault or voltage spikes from the propulsion engine charging system.
5. Disconnect generator set control Connector P1.
6. Inspect pin condition per PSB-676, found in *Product Support Bulletins (603 thru 680)* on QSOL. Insert, repair or replace pins as necessary.
7. Verify the following grounds:
 - HGJAA, HGJAB, HGJAD, and HGJAE models: At P1.27
 - HGJAB and HGJAE models: At P1.17
8. Reconnect Connector P1.
9. Test run the generator set for fault occurrence. Replace the controller.

12.25 Overspeed Fault - Fault Code 31

⚠ WARNING

Some generator set service procedures present hazards that can result in severe personal injury or death. Only trained and experienced persons with knowledge of fuels, electricity, and machinery hazards should perform generator set service. See the Safety Precautions section.

Logic:

- 5 kW Engine Run Only (ERO) mode: Engine RPM via ignition pulse greater than 2880 RPM
- 7 kW Engine Run Only mode: Engine RPM via ignition pulse greater than 3360 RPM

Possible Causes: Engine governor function, fuel supply, air fuel mixture, exhaust system, choke, demand regulator, carburetor, generator drive system, ignition, wire connections

Diagnosis and Repair:

1. Verify that the last fault is FC 31:
 - If "Yes", continue the diagnosis.
 - If "No", troubleshoot the actual last fault.
2. Measure the generator set frequency and droop while running.
3. Measure the AC frequency while changing engine RPM to determine if the frequency response matches the engine RPM response. Repair damaged the generator drive system as necessary.
4. Disconnect generator set control Connector P1.
5. Inspect pin condition per PSB-676, found in *Product Support Bulletins (603 thru 680)* on QSOL. Insert, repair or replace pins as necessary.

-
6. Reconnect Connector P1.
 7. Test run the generator set for fault occurrence. Repair or replace pins in the connector as necessary.
 8. Check air filter cleanliness. Replace the air filter as necessary.
 9. Check for a blocked or damaged exhaust system. Repair or replace exhaust components as necessary.
 10. Run the generator set in ERO mode. Externally excite field F1-F2 with 12 VDC or 24 VDC. Measure AC frequency. If the generator set does not keep running, measure the AC frequency using Break-Out Tool 420-0603 and Instruction Sheet R1098.
 11. **All gasoline models:**
 - a. Vapor lock may occur in high ambient temperatures; operate in ambients at less than 120 °F. Verify proper installation to prevent air recirculation. Correct as necessary.
 - b. Measure steady DC voltage at fuel pump while generator set is cranking. Repair wiring as necessary.
 - c. Try to start generator set on shop fuel supply: verify tank level and fuel line condition in vehicle.
 12. **All gasoline carburetor models:**
 - a. Verify the carburetor altitude setting. Re-adjust as necessary.
 - b. Verify choke operation, setting, linkage, vacuum pull off assembly, and sustain valve. Re-adjust, repair or replace as necessary.
 - c. Measure the fuel pump pressure/flow. Replace the fuel filter or fuel pump as necessary.
 - d. Inspect the carburetor butterfly for binding. Replace the carburetor as necessary.
 13. **All gasoline EFI models:**
 - a. Inspect the throttle body for binding or damage. Replace as necessary.
 - b. Measure the fuel pump pressure/flow. Replace the fuel filter, pressure regulator, or fuel pump as necessary.
 14. **All propane models:**
 - a. Make sure the propane tanks are at least half-full to provide the proper vaporization rate when ambient temperatures are less than 40 °F vapor-withdrawal.
Use HD-5 grade propane. (Propane with more than 2.5% butane will not vaporize in ambients below 32 °F.)
 - b. Measure steady DC voltage at the fuel solenoid while the generator set is running. Repair wiring as necessary.
 - c. Verify a clear vent hose.
 - d. Run the generator set on a shop fuel supply. Verify the tank level and fuel line condition in the vehicle.
 - e. Check the generator set fuel lines for damage. Replace the fuel line as required.
 - f. Measure regulator lock off pressure.
 15. Check the governor, actuator, linkage and spring for debris, damage and looseness. Re-adjust and repair as necessary.
 16. Verify that the spark plug cables are secure on the spark plugs. Reconnect or replace as necessary.
 17. Inspect the ignition kill leads in the harness and at Connector P1. Repair or replace the lead, terminal or pins as necessary.
-

18. Test the magnetos:
 - a. Disconnect Connector P1.
 - b. Connect the positive (+) meter lead to chassis ground.
 - c. Measure continuity to the negative lead at pin P1-4 and P1-5 or P1-15 and P1-20 based on model/spec and control card.
 - When measuring with the negative lead to the shut-off terminal and the positive lead to core, the kill terminal resistance should read between 1 Ohm and 20 Ohms. Replace the magneto if it does not.
 - When measuring with the positive lead on the kill terminal and negative lead to the core, the kill terminal resistance should read higher than 500k Ohms. Replace the magneto if it does not.
19. Measure the spark plug gap. Set the gap or replace spark plugs as necessary.
20. Verify ignition spark condition.
21. Inspect the spark plug lead and kill lead terminal at the magneto. Measure the magneto air gap. Replace the terminals, set the gap, or replace the magnetos as necessary.
22. Measure the temperature of air intake and temperature rise across the generator set. Remove blockage or prevent air recirculation.

NOTICE

Dealers should contact their distributor for technical support; distributors should contact the factory for technical support.

12.26 Low Cranking Speed Sense - Fault Code 32

⚠ WARNING

Some generator set service procedures present hazards that can result in severe personal injury or death. Only trained and experienced persons with knowledge of fuels, electricity, and machinery hazards should perform generator set service. See the Safety Precautions section.

Logic: Quadrature frequency is less than or equal to 3 Hz and engine RPM is less than or equal to 100 RPM for 12 continuous seconds after pressing start.

Possible Causes: Cylinder at TDC, fuel supply, air fuel mixture, exhaust system, starter, choke, demand regulator, carburetor, generator drive system, generator windings, ignition, wire connections

Diagnosis and Repair:

1. Verify that the last fault is FC 32:
 - If "Yes", continue the diagnosis.
 - If "No", troubleshoot the actual last fault.
2. Measure battery voltage at battery and the generator set. Recharge or replace battery as necessary.
3. Verify engine rotation manually. Repair engine damage as necessary.
4. Disconnect the generator set control Connector P1.
5. Inspect pin condition per PSB-676, found in *Product Support Bulletins (603 thru 680)* on QSOL. Insert, repair, or replace pins as necessary.

6. Reconnect Connector P1.
7. Test run the generator set for fault occurrence. Repair or replace pins in the connector as necessary.
8. Measure the DC voltage at the starter during start attempt. Repair wire connections, and replace the start solenoid and starter as necessary.
9. Check air filter cleanliness. Replace the air filter as necessary.
10. Check for blocked or damaged exhaust system. Repair or replace exhaust components as necessary.
11. Run the generator set in Engine Run Only (ERO) mode. Externally excite field F1-F2 with 12 VDC or 24 VDC. Measure the main and quadrature winding AC output. Verify generator set operation and outputs with Break-Out Tool 420-0603 and Instruction Sheet R1098.
12. Measure the AC frequency while changing engine RPM to determine if the frequency response matches the engine RPM response. Repair the damaged generator drive system as necessary.
13. **All gasoline models:**
 - a. Vapor lock may occur in high ambient temperatures; operate in ambients at less than 120°F. Verify proper installation to prevent air recirculation. Correct as necessary.
 - b. Measure steady DC voltage at the fuel pump while the generator set is cranking. Repair the wiring as necessary.
 - c. Start the generator set on shop fuel supply. Verify the tank level and fuel line condition in vehicle.
14. **All gasoline carburetor models:**
 - a. Verify the carburetor altitude setting. Re-adjust as necessary.
 - b. Verify choke operation, setting, linkage, vacuum pull off assembly and sustain valve. Re-adjust, repair or replace as necessary.
 - c. Measure the fuel pump pressure/flow. Replace the fuel filter or fuel pump as necessary.
 - d. Inspect the carburetor butterfly for binding. Replace the carburetor as necessary.
15. **All gasoline EFI models:**
 - a. Inspect the throttle body for binding or damage. Replace as necessary.
 - b. Measure the fuel pump pressure/flow. Replace the fuel filter, pressure regulator, or fuel pump as necessary.
16. **All propane models:**
 - a. When ambient temperatures are less than 40°F vapor-withdrawal, propane tanks should be at least half full to provide proper vaporization rate.
 - b. Propane having more than 2.5 percent Butane will not vaporize in ambients at less than 32°F; use HD-5 grade propane.
 - c. Measure steady DC voltage at fuel solenoid while the generator set is running. Repair wiring as necessary.
 - d. Verify a clear vent hose.
 - e. Run the generator set on a shop fuel supply. Verify the tank level and fuel line condition in vehicle.
 - f. Check the generator set fuel lines for damage. Replace the fuel line as required.
 - g. Measure regulator lock off pressure.
17. Check the governor, actuator, linkage and spring for debris, damage and looseness. Re-adjust and repair as necessary.

18. Verify that the spark plug cables are secure on the spark plugs. Reconnect or replace as necessary.
19. Inspect the ignition kill leads in the harness and at Connector P1. Repair or replace the lead, terminal or pins as necessary.
20. Test the magnetos:
 - a. Disconnect Connector P1.
 - b. Connect the positive (+) meter lead to chassis ground.
 - c. Measure continuity to the negative lead at pin P1-4 and P1-5 or P1-15 and P1-20 based on model/spec and control card.
 - When measuring with the negative lead to the shut-off terminal and the positive lead to core, the kill terminal resistance should read between 1 Ohm and 20 Ohms. Replace the magneto if it does not.
 - When measuring with the positive lead on the kill terminal and negative lead to the core, the kill terminal resistance should read higher than 500k Ohms. Replace the magneto if it does not.
21. Measure the spark plug gap. Set the gap or replace the spark plugs as necessary.
22. Verify ignition spark condition.
23. Inspect the spark plug lead and kill lead terminal at the magneto. Measure the magneto air gap. Replace the terminals, set the gap, or replace the magnetos as necessary.
24. Measure the temperature of air intake and temperature rise across the generator set. Remove blockage or prevent air recirculation.

NOTICE

Dealers should contact their distributor for technical support; distributors should contact the factory for technical support.

12.27 Fault Code 3 - Fault Code 33

⚠ WARNING

Some generator set service procedures present hazards that can result in severe personal injury or death. Only trained and experienced persons with knowledge of fuels, electricity, and machinery hazards should perform generator set service. See the Safety Precautions section.

Logic: There is a single-digit fault which indicates a shutdown due to two-digit fault code.

Possible Cause: Fault Code 3 is interpreted as a non-assigned Fault Code 33.

Diagnosis and Repair:

1. Verify that the last fault is FC 33:
 - If "Yes", continue the diagnosis.
 - If "No", troubleshoot the actual last fault.
2. While the LED is flashing three times, press stop once (1 second duration). Troubleshoot the two-digit fault code.

12.28 Control Card Failure - Fault Code 35

WARNING

Some generator set service procedures present hazards that can result in severe personal injury or death. Only trained and experienced persons with knowledge of fuels, electricity, and machinery hazards should perform generator set service. See the Safety Precautions section.

Logic: There is an EEPROM (programming variables) error during self test.

Possible Causes: Faulty program

Diagnosis and Solution:

1. Verify that the last fault is FC 35:
 - If "Yes", continue the diagnosis.
 - If "No", troubleshoot the actual last fault.
2. Replace the control.

12.29 Generator Set Stopped Without Fault Condition - Fault Code 36

WARNING

Some generator set service procedures present hazards that can result in severe personal injury or death. Only trained and experienced persons with knowledge of fuels, electricity, and machinery hazards should perform generator set service. See Safety Precautions.

Logic: RPM less than 500 and Sense Voltage S1-S2 at 0 VAC when no other fault condition occurred

Possible Causes: Auto Gen Start (AGS), fuel supply, air fuel mixture, exhaust system, loads, Inverter/Charger, choke, demand regulator, carburetor, generator drive system, generator windings, ignition, wire connections

Diagnosis & Repair:

1. Verify that Last Fault is FC 36: Yes, continue diagnosis; No, troubleshoot actual last fault.
2. Verify whether AGS stopped generator set: Yes, disable AGS or explain AGS function to customer (see PSB-666); No, continue diagnosis.
3. Verify engine rotation manually: repair engine damage as necessary.
4. Disconnect generator set control P1 connector, verify P1 pins are fully inserted and inspect pin condition per PSB-676: insert, repair or replace pins as necessary.
5. Reconnect P1 connector and test run generator set for fault occurrence: repair or replace pins in connector as necessary.
6. Check air filter cleanliness; replace air filter as necessary.
7. Check for blocked or damaged exhaust system: repair or replace exhaust components as necessary.
8. Measure AC current while running generator set with vehicle loads: identify faulty or short cycling loads.
9. Determine battery charge rate (typical default is 80 percent): if adjustable reduce to 30 percent.
10. Measure generator set load capability with shop load bank.

-
11. Run generator set in Engine Run Only (ERO) and externally excite field F1-F2 with 12 VDC or 24 VDC and measure main and quadrature winding AC output. Verify generator set operation and outputs with Break-Out Tool 420-0603 and Instruction Sheet R1098.
 12. Measure AC frequency while changing engine rpm to determine if frequency response matches engine rpm response: repair damaged generator drive system as necessary.
 13. **All Gasoline Models**
 - a. Vapor lock may occur in high ambient temperatures: operate in ambients at less than 120°F; verify proper installation to prevent air recirculation; correct as necessary.
 - b. Measure steady DC voltage at fuel pump while generator set is cranking: repair wiring as necessary.
 - c. Try to start generator set on shop fuel supply: verify tank level and fuel line condition in vehicle.
 14. **All Gasoline Carburetor Models**
 - a. Verify carburetor altitude setting: readjust as necessary.
 - b. Verify choke operation, setting, linkage, vacuum pull off assembly and sustain valve: readjust, repair or replace as necessary.
 - c. Measure fuel pump pressure/flow: replace fuel filter or fuel pump as necessary.
 - d. Inspect carburetor butterfly for binding: replace carburetor as necessary.
 15. **All Gasoline EFI Models**
 - a. Inspect throttle body for binding or damage: replace as necessary.
 - b. Measure fuel pump pressure/flow: replace fuel filter, pressure regulator or fuel pump as necessary.
 16. **Propane Models**
 - a. When ambient temperatures are less than 40°F vapor-withdrawal, propane tanks should be at least half full to provide proper vaporization rate.
 - b. Propane having more than 2.5 percent Butane will not vaporize in ambients at less than 32°F; use HD-5 grade propane.
 - c. Measure steady DC voltage at fuel solenoid while generator set is running; repair wiring as necessary.
 - d. Verify clear vent hose.
 - e. Run generator set on shop fuel supply; verify tank level and fuel line condition in vehicle.
 - f. Check generator set fuel lines for damage: replace fuel line as required.
 - g. Measure regulator lock off pressure.
 17. Check governor, actuator, linkage and spring for debris, damage and looseness: readjust and repair as necessary.
 18. Verify that spark plug cables are secure on spark plugs: reconnect or replace as necessary.
 19. Inspect ignition kill leads in harness and at connector P1: repair or replace lead, terminal or pins as necessary.
 20. Test Magnetos
 - a. Disconnect Connector P1.
 - b. Connect positive (+) meter lead to chassis ground.
 - c. Measure continuity to negative lead at pin P1-4 and P1-5 or P1-15 and P1-20 based on model/spec and control card: replace magnetos as necessary.
-

21. Measure spark plug gap: set gap or replace spark plugs as necessary.
22. Verify ignition spark condition.
23. Inspect spark plug lead, kill lead terminal at magneto and measure magneto air gap: replace terminals, set gap or replace magnetos as necessary.
24. Measure temperature of air intake and temperature rise across generator set; remove blockage or prevent air recirculation.
25. Conduct the hot air recirculation test (Refer to Installation Manual).
26. Dealers contact Distributor for technical support, Distributors contact factory for technical support.

12.30 Invalid Set Configuration - Fault Code 37

WARNING

Some generator set service procedures present hazards that can result in severe personal injury or death. Only trained and experienced persons with knowledge of fuels, electricity, and machinery hazards should perform generator set service. See the Safety Precautions section.

Logic: Configuration is determined by ratio of quadrature frequency / ignition speed

Possible Causes: Wire connections, windings, ignition system, drive belt slippage, generator drive system

Diagnosis and Repair:

1. Verify that the last fault is FC 37:
 - If "Yes", continue the diagnosis.
 - If "No", troubleshoot the actual last fault.
2. If FC 37 and FC 47 are alternating, the magneto gap is too wide. Reset the magneto gap and retest.
3. Run the generator set in Engine Run Only (ERO) mode. Externally excite field with 12 VDC or 24 VDC. Measure the main and quadrature winding AC output. If the generator set does not keep running, measure the generator set frequency, and the quadrature and main winding voltages using Break-Out Tool 420-0603 and Instruction Sheet R1098.
4. Measure the AC frequency while changing the engine RPM to determine if frequency response matches engine RPM response. Repair the damaged generator drive system as necessary.
5. Measure the field, quadrature, and main winding resistance. Clean the slip rings, replace the brushes, repair the harness, and replace the rotor or stator as necessary.
6. Measure the field, quadrature, and main winding resistance to ground. Clean the slip rings, replace the brushes, repair the harness, and replace the rotor or stator as necessary.
7. Measure the field, quadrature, and main winding resistance to each other. Clean the slip rings, replace the brushes, repair the harness, and replace the rotor or stator as necessary.
8. Check the brush alignment per CPGF-S-00000258-0.
9. Verify that the spark plug cables are secure on the spark plugs. Reconnect or replace as necessary.
10. Inspect the ignition kill leads in the harness and at Connector P1. Repair or replace lead, terminal or pins as necessary.
11. Test the magnetos:
 - a. Disconnect Connector P1.
 - b. Connect the positive (+) meter lead to chassis ground.

- c. Measure continuity to the negative lead at pin P1-4 and P1-5 or P1-15 and P1-20 based on model/spec and control card.
 - When measuring with the negative lead to the shut-off terminal and the positive lead to core, the kill terminal resistance should read between 1 Ohm and 20 Ohms. Replace the magneto if it does not.
 - When measuring with the positive lead on the kill terminal and negative lead to the core, the kill terminal resistance should read higher than 500k Ohms. Replace the magneto if it does not.
12. Measure the spark plug gap. Set the gap or replace the spark plugs as necessary.
13. Verify ignition spark condition.
14. Inspect the spark plug lead and kill lead terminal at the magneto. Measure the magneto air gap. Replace the terminals, set the gap, or replace magnetos as necessary.
15. Check the control board on the generator set. Make sure that it has the right board.

NOTICE

Dealers should contact their distributor for technical support; distributors should contact the factory for technical support.

12.31 Field Overload (Overvoltage) - Fault Code 38

⚠ WARNING

Some generator set service procedures present hazards that can result in severe personal injury or death. Only trained and experienced persons with knowledge of fuels, electricity, and machinery hazards should perform generator set service. See the Safety Precautions section.

Logic: The field voltage (F1-F1) is greater than 150 VDC for 10 continuous seconds.

Possible Causes: Loads, inverter/charger, windings, fuel supply, governor system

Diagnosis and Repair:

1. Verify that the last fault is FC 38:
 - If "Yes", continue the diagnosis.
 - If "No", troubleshoot the actual last fault.
2. Measure the F1-F2 DC voltage.
3. Measure the AC current while running the generator set with vehicle loads. Identify the faulty or short cycling loads.
4. Determine the battery charge rate (typical default is 80%). If adjustable, reduce to 30%.
5. Disconnect generator set control Connector P1.
6. Inspect pin condition per PSB-676, found in *Product Support Bulletins (603 thru 680)* on QSOL. Insert, repair, or replace pins as necessary.
7. Reconnect Connector P1.
8. Test run the generator set for fault occurrence. Repair or replace pins in Connector P1 as necessary.
9. Measure generator set load capability with a shop load bank (derate for altitude and temperature as necessary).

-
10. Measure the generator set frequency and droop while running.
 11. Check the governor, actuator, linkage and spring for debris, damage and looseness. Re-adjust and repair as necessary.
 12. Check air filter cleanliness. Replace the air filter as necessary.
 13. Check for blocked or damaged exhaust system. Repair or replace exhaust components as necessary.
 14. **All gasoline models:**
 - a. Vapor lock may occur in high ambient temperatures: operate in ambients at less than 120°F. Verify proper installation to prevent air recirculation. Correct as necessary.
 - b. Measure steady DC voltage at the fuel pump while the generator set is cranking. Repair the wiring as necessary.
 - c. Start the generator set on a shop fuel supply. Verify the tank level and fuel line condition in the vehicle.
 15. **All gasoline carburetor models:**
 - a. Verify the carburetor altitude setting. Re-adjust as necessary.
 - b. Verify choke operation, setting, linkage, vacuum pull off assembly and sustain valve. Re-adjust, repair or replace as necessary.
 - c. Measure the fuel pump pressure/flow. Replace the fuel filter or fuel pump as necessary.
 - d. Inspect the carburetor butterfly for binding. Replace the carburetor as necessary.
 16. **All gasoline EFI models:**
 - a. Inspect the throttle body for binding or damage. Replace as necessary.
 - b. Measure the fuel pump pressure/flow. Replace the fuel filter, pressure regulator, or fuel pump as necessary.
 17. **All propane models:**
 - a. Make sure the propane tanks are at least half-full to provide the proper vaporization rate when ambient temperatures are less than 40 °F vapor-withdrawal.

Use HD-5 grade propane. (Propane with more than 2.5% butane will not vaporize in ambients below 32 °F.)
 - b. Measure steady DC voltage at the fuel solenoid while the generator set is running. Repair the wiring as necessary.
 - c. Verify a clear vent hose.
 - d. Run the generator set on a shop fuel supply. Verify the tank level and fuel line condition in the vehicle.
 - e. Check the generator set fuel lines for damage. Replace the fuel line as required.
 - f. Measure the regulator lock off pressure.
 18. Check the governor, actuator, linkage and spring for debris, damage, and looseness. Re-adjust and repair as necessary.
 19. Run the generator set in Engine Run Only (ERO). Externally excite field F1-F2 with 12 VDC or 24 VDC. Measure the main and quadrature winding AC output. If the generator set does not keep running, measure the generator set frequency, quadrature winding, and main winding voltages using Break-Out Tool 420-0603 and Instruction Sheet R1098.
 20. Remove Connector P1 from the control.
 21. Re-install and start the generator set. Inspect, repair or replace Connector P1 pins as necessary.
-

22. Measure the field, quadrature, and main winding resistance. Clean the slip rings, replace the brushes, repair the harness, and replace the rotor or stator as necessary.
23. Measure field, quadrature and main winding resistance to ground. Clean the slip rings, replace the brushes, repair the harness, and replace the rotor or stator as necessary.
24. Measure field, quadrature and main winding resistance to each other. Clean the slip rings, replace the brushes, repair the harness, and replace the rotor or stator as necessary.
25. Check the brush alignment per CPGF-S-00000258-0.
26. Measure the temperature of air intake and temperature rise across the generator set. Remove blockage or prevent air recirculation.

NOTICE

Dealers should contact their distributor for technical support; distributors should contact the factory for technical support.

12.32 Alternator Rotor Fault - Fault Code 41

⚠ WARNING

Some generator set service procedures present hazards that can result in severe personal injury or death. Only trained and experienced persons with knowledge of fuels, electricity, and machinery hazards should perform generator set service. See the Safety Precautions section.

Logic: Only active after 2003: Field Voltage F1-F2 at 0 VDC and Sense Voltage S1-S2 at 0 VAC for 1 continuous second

Possible Causes: Loads, windings, fuel supply

Diagnosis and Repair:

1. Verify that the last fault is FC 41:
 - If "Yes", continue the diagnosis.
 - If "No", troubleshoot the actual last fault.
2. Measure the F1-F2 DC voltage.
3. Measure the AC current while running the generator set with vehicle loads. Identify faulty or short cycling loads.
4. Determine the battery charge rate (the typical default is 80%). If adjustable, reduce it to 30%.
5. Disconnect generator set control Connector P1.
6. Inspect pin condition per PSB-676, found in *Product Support Bulletins (603 thru 680)* on QSOL. Insert, repair, or replace pins as necessary.
7. Reconnect Connector P1.
8. Test run the generator set for fault occurrence. Repair or replace pins in the connector as necessary.
9. Measure the generator set load capability with a shop load bank (derate for altitude and temperature as necessary).
10. **All gasoline models:**
 - a. Vapor lock may occur in high ambient temperatures; operate in ambients at less than 120 °F. Verify proper installation to prevent air recirculation. Correct as necessary.

-
- b. Measure steady DC voltage at the fuel pump while the generator set is cranking. Repair the wiring as necessary.
 - c. Start the generator set on a shop fuel supply. Verify the tank level and fuel line condition in the vehicle.
11. **All gasoline carburetor models:**
 - a. Verify the carburetor altitude setting. Re-adjust as necessary.
 - b. Verify choke operation, setting, and linkage. Vacuum pull off assembly and sustain valve. Re-adjust, repair or replace as necessary.
 - c. Measure the fuel pump pressure/flow. Replace the fuel filter or fuel pump as necessary.
 - d. Inspect the carburetor butterfly for binding. Replace the carburetor as necessary.
 12. **All gasoline EFI models:**
 - a. Inspect the throttle body for binding or damage. Replace as necessary.
 - b. Measure the fuel pump pressure/flow. Replace the fuel filter, pressure regulator, or fuel pump as necessary.
 13. **All propane models:**
 - a. Make sure the propane tanks are at least half-full to provide the proper vaporization rate when ambient temperatures are less than 40 °F vapor-withdrawal.
 - b. Use HD-5 grade propane. (Propane with more than 2.5% butane will not vaporize in ambients below 32 °F.)
 - c. Measure steady DC voltage at the fuel solenoid while the generator set is running. Repair the wiring as necessary.
 - d. Verify a clear vent hose.
 - e. Run the generator set on a shop fuel supply. Verify the tank level and fuel line condition in the vehicle.
 - f. Check the generator set fuel lines for damage. Replace the fuel line as required.
 - g. Measure the regulator lock off pressure.
 14. Check the governor, actuator, linkage and spring for debris, damage, and looseness. Re-adjust and repair as necessary.
 15. Run the generator set in Engine Run Only (ERO) mode. Externally excite field F1-F2 with 12 VDC or 24 VDC. Measure the main and quadrature winding AC output. If the generator set does not keep running. Measure the generator set frequency, quadrature winding, and main winding voltages using Break-Out Tool 420-0603 and Instruction Sheet R1098.
 16. Remove Connector P1 from the control.
 17. Re-install and start the generator set. Inspect, repair or replace connector pins as necessary.
 18. Measure the field, quadrature and main winding resistance. Clean the slip rings, replace the brushes, repair the harness, and replace the rotor or stator as necessary.
 19. Measure the field, quadrature and main winding resistance to ground. Clean the slip rings, replace the brushes, repair the harness, and replace the rotor or stator as necessary.
 20. Measure the field, quadrature and main winding resistance to each other. Clean the slip rings, replace the brushes, repair the harness, and replace the rotor or stator as necessary.
 21. Check brush alignment per CPGF-S-00000258-0.
 22. Measure the temperature of the air intake and temperature rise across the generator set. Remove blockage or prevent air recirculation.
-

NOTICE

Dealers should contact their distributor for technical support; distributors should contact the factory for technical support.

12.33 Processor Fault - Fault Code 42

⚠ WARNING

Some generator set service procedures present hazards that can result in severe personal injury or death. Only trained and experienced persons with knowledge of fuels, electricity, and machinery hazards should perform generator set service. See Safety Precautions section.

Logic: There is a ROM (programming variables) error during self-test.

Possible Cause: Faulty program

Diagnosis and Solution:

1. Verify that the last fault is FC 42:
 - If "Yes", continue the diagnosis.
 - If "No", troubleshoot the actual last fault.
2. Replace the control.

12.34 Processor Fault - Fault Code 43

⚠ WARNING

Some generator set service procedures present hazards that can result in severe personal injury or death. Only trained and experienced persons with knowledge of fuels, electricity, and machinery hazards should perform generator set service. See Safety Precautions section

Logic: RAM (programming variables) error during self test

Possible Cause: Faulty program

Diagnosis and Solution:

1. Verify that the last fault is FC 43:
 - If "Yes", continue the diagnosis.
 - If "No", troubleshoot the actual last fault.
2. Replace the control.

12.35 Speed Sense Fault - Fault Code 45

⚠ WARNING

Some generator set service procedures present hazards that can result in severe personal injury or death. Only trained and experienced persons with knowledge of fuels, electricity, and machinery hazards should perform generator set service. See the Safety Precautions section.

Logic: While running, the quadrature frequency dropped to 0 Hz for 1 continuous second.

Possible Causes: Auto Gen Start (AGS), fuel supply, air fuel mixture, exhaust system, loads, inverter/charger, choke, demand regulator, carburetor, generator drive system, alternator windings, ignition, wire connections

Diagnosis and Repair:

1. Verify that the last fault is FC 45:
 - If "Yes", continue the diagnosis.
 - If "No", troubleshoot the actual last fault.
2. Verify whether AGS stopped the generator set:
 - If "Yes", disable AGS or explain AGS function to customer (see PSB-666).
 - If "No", continue the diagnosis.
3. Verify engine rotation manually. Repair engine damage as necessary.
4. Disconnect generator set control Connector P1.
5. Inspect pin condition per PSB-676, found in *Product Support Bulletins (603 thru 680)* on QSOL. Insert, repair, or replace pins as necessary.
6. Reconnect Connector P1.
7. Test run the generator set for fault occurrence. Repair or replace pins in the connector as necessary.
8. Check air filter cleanliness. Replace the air filter as necessary.
9. Check for a blocked or damaged exhaust system. Repair or replace exhaust components as necessary.
10. Measure AC current while running the generator set with vehicle loads. Identify faulty or short cycling loads.
11. Determine the battery charge rate (typical default is 80%). If adjustable, reduce to 30%.
12. Measure generator set load capability with a shop load bank (derate for altitude and temperature as necessary).
13. Run the generator set in Engine Run Only (ERO) mode. Externally excite field F1-F2 with 12 VDC or 24 VDC. Measure the main and quadrature winding AC output. Verify generator set operation and outputs with Break-Out Tool 420-0603 and Instruction Sheet R1098.
14. Measure the generator set frequency and droop while running.
15. Measure the AC frequency while changing engine RPM to determine if the frequency response matches the engine RPM response. Repair the damaged generator drive system as necessary.
16. **All gasoline models:**
 - a. Vapor lock may occur in high ambient temperatures: operate in ambients at less than 120 °F. Verify proper installation to prevent air recirculation. Correct as necessary.
 - b. Measure steady DC voltage at the fuel pump while the generator set is cranking. Repair the wiring as necessary.
 - c. Start the generator set on a shop fuel supply. Verify the tank level and fuel line condition in the vehicle.
17. **All gasoline carburetor models:**
 - a. Verify the carburetor altitude setting. Re-adjust as necessary.
 - b. Verify choke operation, setting, linkage, vacuum pull off assembly and sustain valve. Re-adjust, repair or replace as necessary.

-
- c. Measure the fuel pump pressure/flow. Replace the fuel filter or fuel pump as necessary.
 - d. Inspect the carburetor butterfly for binding. Replace the carburetor as necessary.
18. **All gasoline EFI models:**
- a. Inspect the throttle body for binding or damage. Replace as necessary.
 - b. Measure the fuel pump pressure/flow. Replace the fuel filter, pressure regulator or fuel pump as necessary.
19. **All propane models:**
- a. Make sure the propane tanks are at least half-full to provide the proper vaporization rate when ambient temperatures are less than 40 °F vapor-withdrawal.
 - b. Use HD-5 grade propane. (Propane with more than 2.5% butane will not vaporize in ambients below 32 °F.)
 - c. Measure steady DC voltage at the fuel solenoid while the generator set is running. Repair wiring as necessary.
 - d. Verify a clear vent hose.
 - e. Run the generator set on a shop fuel supply. Verify the tank level and fuel line condition in the vehicle.
 - f. Check the generator set fuel lines for damage. Replace the fuel line as required.
 - g. Measure the regulator lock off pressure.
20. Check the governor, actuator, linkage ,and spring for debris, damage, and looseness. Re-adjust and repair as necessary.
21. Verify that the spark plug cables are secure on the spark plugs. Reconnect or replace as necessary.
22. Test the magnetos:
- a. Disconnect Connector P1.
 - b. Connect the positive (+) meter lead to chassis ground.
 - c. Measure continuity to the negative lead at pin P1-4 and P1-5 or P1-15 and P1-20 based on model/spec and control card.
 - When measuring with the negative lead to the shut-off terminal and the positive lead to core, the kill terminal resistance should read between 1 Ohm and 20 Ohms. Replace the magneto if it does not.
 - When measuring with the positive lead on the kill terminal and negative lead to the core, the kill terminal resistance should read higher than 500k Ohms. Replace the magneto if it does not.
23. Inspect the ignition kill leads in the harness and at Connector P1. Repair or replace lead, terminal or pins as necessary.
24. Measure the spark plug gap. Set the gap or replace the spark plugs as necessary.
25. Verify ignition spark condition.
26. Inspect the spark plug lead and kill lead terminal at the magneto. Measure the magneto air gap. Replace the terminals, set the gap or replace the magnetos as necessary.
27. Measure the temperature of air intake and temperature rise across the generator set. Remove blockage or prevent air recirculation.

NOTICE

Dealers should contact their distributor for technical support; distributors should contact the factory for technical support.

12.36 Ignition Fault - Fault Code 47

⚠ WARNING

Some generator set service procedures present hazards that can result in severe personal injury or death. Only trained and experienced persons with knowledge of fuels, electricity, and machinery hazards should perform generator set service. See the Safety Precautions section.

Logic:

- Loss of ignition sense
- HGJAB and HGJAE - Enabled only in Engine Run Only (ERO) only
- HGJAA and HGJAD - Enabled when generator set running and in ERO mode

Possible Causes: Wire connections, windings, ignition system, generator drive system

Diagnosis & Repair:

1. Verify that the last fault is FC 47:
 - If "Yes", continue the diagnosis.
 - If "No", troubleshoot the actual last fault.
2. Alternating FC 47 and FC 37: If the magneto gap is too wide, reset the magneto gap and retest.
3. Test magnetos:
 - a. Disconnect Connector P1.
 - b. Connect the positive (+) meter lead to chassis ground.
 - c. Measure continuity to the negative lead at pin P1-4 and P1-5 or P1-15 and P1-20 based on model/spec and control card.
 - When measuring with the negative lead to the shut-off terminal and the positive lead to core, the kill terminal resistance should read between 1 Ohm and 20 Ohms. Replace the magneto if it does not.
 - When measuring with the positive lead on the kill terminal and negative lead to the core, the kill terminal resistance should read higher than 500k Ohms. Replace the magneto if it does not.
4. Run the generator set in ERO and externally excite field with 12 VDC or 24 VDC.
5. Measure main and quadrature winding AC output. If the generator set will not stay running, measure the generator set frequency, the quadrature winding voltage, and the main winding voltage using Break-Out Tool 420-0603 and Instruction Sheet R1098.
6. Measure AC frequency while changing engine RPM to determine if the frequency response matches engine RPM response. Repair the damaged generator drive system as necessary.
7. Measure field, quadrature winding resistance, and main winding resistance. Clean slip rings, replace brushes, repair the harness, and replace the rotor or stator as necessary.
8. Measure field, and quadrature and main winding resistances to ground. Clean slip rings, replace brushes, repair harness and replace the rotor or stator as necessary.

9. Measure field, and quadrature and main winding resistance to each other. Clean slip rings, replace brushes, repair the harness, and replace the rotor or stator as necessary.
10. Check brush alignment per CPGF-S-00000258-0.
11. Verify that the spark plug cables are secure on spark plugs. Reconnect or replace as necessary.
12. Inspect the ignition kill leads in the harness and at connector P1. Repair or replace lead, terminal or pins as necessary.
13. Measure the spark plug gap. Set the gap or replace spark plugs as necessary.
14. Verify ignition spark condition.
15. Inspect the spark plug lead and kill lead terminal at magneto. Then measure the magneto air gap. Replace the terminals, set the gap or replace magnetos as necessary.

NOTICE

Dealers should contact their distributor for technical support; distributors should contact the factory for technical support.

12.37 Field Sense Fault - Fault Code 48

⚠ WARNING

Some generator set service procedures present hazards that can result in severe personal injury or death. Only trained and experienced persons with knowledge of fuels, electricity, and machinery hazards should perform generator set service. See the Safety Precautions section.

Logic: The controller is unable to sense field voltage.

Possible Cause: Faulty control

Diagnosis and Solution:

1. Verify that the last fault is FC 48:
 - If "Yes", continue the diagnosis.
 - If "No", troubleshoot the actual last fault.
2. Replace the control.

12.38 Processor Failure - Fault Code 51

⚠ WARNING

Some generator set service procedures present hazards that can result in severe personal injury or death. Only trained and experienced persons with knowledge of fuels, electricity, and machinery hazards should perform generator set service. See the Safety Precautions section.

Logic: Processor error

Possible Cause: Faulty control

Diagnosis and Solution:

1. Verify that the last fault is FC 51:
 - If "Yes", continue the diagnosis.
 - If "No", troubleshoot the actual last fault.
2. Use the breakout board to perform tests in Instruction Sheet R1098.
3. Replace the control.

12.39 Fuel Injector Fault (EFI Only) - Fault Code 52

⚠ WARNING

Some generator set service procedures present hazards that can result in severe personal injury or death. Only trained and experienced persons with knowledge of fuels, electricity, and machinery hazards should perform generator set service. See the Safety Precautions section.

Logic: Open or shorted fuel injector

Possible Causes: P1-17, wire connections, fuel injector

Diagnosis and Solution:

1. Verify that the last fault is FC 52:
 - If "Yes", continue the diagnosis.
 - If "No", troubleshoot the actual last fault.
2. Measure P1-17 open to ground on the EFI set. Ground the lead as required for carburetor configuration.
3. Inspect the connector at the injectors for looseness and damage. Repair or replace the connector as necessary.
4. Disconnect generator set control Connector P1.
5. Inspect pin condition per PSB-676, found in *Product Support Bulletins (603 thru 680)* on QSOL. Insert, repair, or replace pins as necessary.
6. Reconnect Connector P1.
7. Test run the generator set for fault occurrence. Repair or replace pins in the connector as necessary.
8. Measure for continuity between P1-23 - INJ1 and P1-35 - INJ2. Repair or replace the harness as necessary.
9. Measure for continuity to ground from P1-23, P1-35, INJ1 and INJ2. Repair or replace the harness as necessary.
10. Replace the injector.

NOTICE

Dealers should contact their distributor for technical support; distributors should contact the factory for technical support.

12.40 MAT Sensor Fault (EFI Only) - Fault Code 54

WARNING

Some generator set service procedures present hazards that can result in severe personal injury or death. Only trained and experienced persons with knowledge of fuels, electricity, and machinery hazards should perform generator set service. See the Safety Precautions section.

Logic: The MAT sender input is greater than 300k Ohms.

Possible Causes: P1-17, wire connections, MAT sender

Diagnosis and Solution:

1. Verify that the last fault is FC 54:
 - If "Yes", continue the diagnosis.
 - If "No", troubleshoot the actual last fault.
2. Measure P1-17 open to ground on EFI set. Ground the lead as required for carburetor configuration.
3. Inspect the connector at the sender for looseness and damage. Repair or replace the connector as necessary.
4. Disconnect the generator set control Connector P1.
5. Inspect pin condition per PSB-676, found in *Product Support Bulletins (603 thru 680)* on QSOL. Insert, repair, or replace pins as necessary.
6. Reconnect Connector P1.
7. Test run the generator set for fault occurrence. Repair or replace pins in the connector as necessary.
8. Measure for continuity across harness between P1-25 - MAT(A) and P1-20 - MAT(B). Repair or replace the harness as necessary.
9. Measure the resistance of MAT. Replace the sender as necessary.

NOTICE

Dealers should contact their distributor for technical support; distributors should contact the factory for technical support.

12.41 MAP Sensor Fault (EFI Only) - Fault Code 56

WARNING

Some generator set service procedures present hazards that can result in severe personal injury or death. Only trained and experienced persons with knowledge of fuels, electricity, and machinery hazards should perform generator set service. See the Safety Precautions section.

Logic: The MAP sensor input is less than 50 kPa at start.

Possible Causes: P1-17, ambient pressure/altitude, wire connections, MAP sender, wide open throttle (WOT) during start

Diagnosis and Solution:

1. Verify that the last fault is FC 56:
 - If "Yes", continue the diagnosis.
 - If "No", troubleshoot the actual last fault.
2. Measure P1-17 open to ground on EFI set. Ground the lead as required for carburetor configuration.
3. Verify ambient pressure is greater than 50 kPa. Change altitude.
4. Inspect the connector at the sender for looseness and damage. Repair or replace the connector as necessary.
5. Disconnect generator set control Connector P1.
6. Inspect pin condition per PSB-676, found in *Product Support Bulletins (603 thru 680)* on QSOL. Insert, repair, or replace pins as necessary.
7. Reconnect Connector P1. Test run generator set for fault occurrence. Repair or replace pins in the connector as necessary.
8. Measure for continuity across the harness between P1-31 - MAP(A), P1-22 - MAP(B) and P1-30 - MAP(C). Repair or replace the harness as necessary.
9. Measure resistance on the sender between MAP(A), MAP(B) and MAP(C). Replace the sender as necessary.
10. Measure the fuel pump pressure/flow. Replace the fuel filter, pressure regulator or fuel pump as necessary.

NOTICE

Dealers should contact their distributor for technical support; distributors should contact the factory for technical support.

12.42 Overprime Fault - Fault Code 57

⚠ WARNING

Some generator set service procedures present hazards that can result in severe personal injury or death. Only trained and experienced persons with knowledge of fuels, electricity, and machinery hazards should perform generator set service. See the Safety Precautions section.

Logic: The generator set has been priming for 3 consecutive minutes.

Possible Causes: Wiring harness, faulty switch, AGS

Diagnosis and Repair:

1. Verify that the last fault is FC 57:
 - If "Yes", continue the diagnosis.
 - If "No", troubleshoot the actual last fault.
2. Check for an object holding the switch in the stop position. Remove the object.
3. Disconnect generator set control Connector P1.
4. Inspect pin condition per PSB-676, found in *Product Support Bulletins (603 thru 680)* on QSOL. Insert, repair, or replace pins as necessary

5. Reconnect Connector P1.
6. Test run the generator set for fault occurrence. Repair or replace pins in the connector as necessary.
7. Measure for continuity change across the start/stop switch between the neutral and stop positions at the switches and Connector P1. Replace the switches as necessary, or disconnect the external stop device if so equipped.

NOTICE

Dealers should contact their distributor for technical support; distributors should contact the factory for technical support.

This page is intentionally blank.

13 Service Checklist

13.1 General

Before reinstalling the generator set, repair any damage to and seal all holes in the vapor-tight, fire-resistant barrier between the generator set and the coach interior.

After servicing or reinstalling a generator set, conduct the following checks and tests to determine that the generator set will operate safely and perform as required.

13.2 Mounting

Check for proper mounting and tighten all fasteners securely. Make sure the air inlet and outlet openings in the bottom of the generator set are not restricted in any way, and that there is access for changing the oil filter and draining oil.

13.3 Wiring

⚠ WARNING

Batteries give off explosive gases that can cause severe personal injury — Do not smoke — Keep flames, sparks, pilot lights, switches, arc-producing equipment and all other ignition sources away.

Make sure all AC output, control, ground and battery connections are tight and properly installed. Check wiring for cuts, cracks and abrasions and make sure it does not rub against anything that could cause damage.

13.4 Exhaust System

Make certain that the exhaust tail pipe terminates beyond the perimeter of the vehicle and not near vents or openable windows or doors. Test the on-board CO alarm(s). See the installation manual for important considerations concerning the installation of an exhaust system.

When the generator set is up and running, look and listen for leaks at all connections, welds, gaskets, and joints along the whole length of the exhaust system. Repair all leaks before putting the generator set in service.

13.5 Fuel System

Check flexible sections for cuts, cracks and abrasions and make sure they do not rub against anything that could cause damage. On models equipped with fuel injection, make sure proper connections have been made for a fuel return line all the way back to the fuel tank.

⚠ WARNING

Gasoline is flammable and explosive and can cause severe personal injury or death.

- ***Stop priming immediately if you smell gasoline or see fuel leaking, and clean up spilled fuel and ventilate area before starting the generator set or vehicle.***
- ***Do not smoke.***
- ***Keep flames, sparks, pilot lights, switches, arc-producing equipment and all other ignition sources away.***
- ***Keep an ABC fire extinguisher handy.***

Gasoline Models:

1. Recheck all fuel connections for tightness.
2. Prime the fuel system by holding the control switch at **STOP/PRIME** while checking for fuel line leaks.
3. Fix all leaks before starting the generator set.

⚠ WARNING

LPG is flammable and explosive and can cause asphyxiation. NFPA 58, Section 1.6 requires all persons handling LPG to be trained in proper handling and operating procedures.

⚠ WARNING

LPG "sinks" and can accumulate in explosive concentrations. Before connecting or disconnecting the LPG fuel line, close the fuel shutoff valve(s) at the LPG container(s) and move the vehicle outside and away from pits, basements, and other below-grade spaces where LPG could accumulate.

LPG Models:

1. Recheck all fuel connections for tightness.
2. Make sure proper connections have been made at the LPG container(s). A generator set equipped for low-pressure LPG (vapor withdrawal) must not be connected for high-pressure (liquid withdrawal), and vice versa.
3. For low-pressure LPG, check and adjust the LPG supply pressure to obtain 228 – 330 mm (9 – 13 inches) WC (water column) at all loads.
4. Fix all leaks before starting the generator set.

13.6 Startup

⚠ WARNING

EXHAUST GAS IS DEADLY! Do not operate the generator set when the vehicle is indoors or where exhaust can accumulate.

⚠ CAUTION

Frequency-sensitive equipment such as VCRs, televisions, computers, etc., can be damaged by power line frequency variations. Some solid-state devices are powered whenever connected to an AC outlet even if the device is not in actual operation. For this reason, disconnect all devices that are voltage- or frequency-sensitive before attempting any governor adjustments. If disconnecting the devices is not possible, open the circuit breaker(s) at the distribution panel or at the generator set.

1. Read the operator manual and perform the maintenance and pre-start checks instructed. Check the oil level and fill as necessary.
2. If the generator set is equipped with a mechanical governor and frequency adjustments have yet to be made, make sure all frequency-sensitive equipment has been disconnected.
3. Start the generator set and adjust the governor as necessary (see [Chapter 9](#)).
4. Operate the generator set following all the instructions and safety precautions in the operator manual.
5. Check for fuel and exhaust leaks and unusual noises while the generator set is running under full and intermediate loads. Do not place the generator set in service until all fuel and exhaust leaks have been fixed and operation is satisfactory.

13.7 Output Check

Apply a full load to make sure the generator set can produce its full rated output. Use a load test panel to apply a progressively greater load until full load is reached.

13.8 Control

Stop and start the generator set several times at the generator set control and remote control (if equipped) to verify that it functions properly.

This page is intentionally blank.

14 Specifications

14.1 Specifications

	GASOLINE MODELS					
	7.0 HGJAA	7.0 HGJAB	7.0 HGJAC	5.5 HGJAA	5.5 HGJAB	5.5 HGJAC
GENERATOR: 2-Pole Revolving Field, 2-Bearing, Self-Excited, 1-Phase, Vertical Shaft, Capped Digital Voltage Regulation						
Power	7000 watts			5500 watts		
Frequency	60 Hertz			60 Hertz		
Voltage	120 volts			120 volts		
Current	58.3 amp			45.8 amp		
Speed	3600 rpm			3600 rpm		
FUEL CONSUMPTION:						
No load	0.43 gph (1.6 l/h)	0.43 gph (1.6 l/h)	0.43 gph (1.6 l/h)	0.34 gph (1.3 l/h)	0.35 gph (1.3 l/h)	0.35 gph (1.3 l/h)
Half load	0.70 gph (2.7 l/h)	0.73 gph (2.8 l/h)	0.73 gph (2.8 l/h)	0.58 gph (2.2 l/h)	0.60 gph (2.3 l/h)	0.60 gph (2.3 l/h)
Full load	1.13 gph (4.3 l/h)	1.22 gph (4.6 l/h)	1.22 gph (4.6 l/h)	0.89 gph (3.4 l/h)	0.95 gph (3.6 l/h)	0.95 gph (3.6 l/h)
ENGINE: Air-Cooled, 4-Cycle Spark-Ignited, OHV, 90° V Twin Cyl, Vertical Shaft						
Fueling Method	SFI ¹	Carburetor	Carburetor	SFI ¹	Carburetor	Carburetor
Governor	Digital	Mechanical	Mechanical	Digital	Mechanical	Mechanical
Speed	2880 rpm			2400 rpm		
Bore	3.15 in (80 mm)			3.15 in (80 mm)		
Stroke	2.56 in (65 mm)			2.56 in (65 mm)		
Displacement	39.8 in ³ (653 cc)			39.8 in ³ (653 cc)		
Comp. Ratio	8.0 : 1			8.0 : 1		
Cyl. Comp. Test	153-188 psi			153-188 psi		
Oil Capacity	2.0 quart (1.8 l)			2.0 quart (1.8 l)		
Valve Lash (Cold)	0.004 in (0.10 mm), Intake & Exhaust			0.004 in (0.10 mm), Intake & Exhaust		
Spark Plug	18-25 lbs-ft (23-32 N-m)			18-25 lbs-ft (23-32 N-m)		
Ignition Timing	20° BTDC, non-adjustable magneto			20° BTDC, non-adjustable magneto		
Magneto Air Gap	0.012 in (0.3 mm)			0.012 in (0.3 mm)		
Spark Plug Gap	0.025 in (0.6-0.7 mm)			0.025 in (0.6-0.7 mm)		

	GASOLINE MODELS					
	7.0 HGJAA	7.0 HGJAB	7.0 HGJAC	5.5 HGJAA	5.5 HGJAB	5.5 HGJAC
DC SYSTEM:						
Battery Voltage	12 volts			12 volts		
Min. Battery CCA	450 @ 0° F (-18° C)			450 @ 0° F (-18° C)		
INSTALLATION:						
Exhaust O. D.	1-1/4 in			1-1/4 in		
Max. Exhaust Back Pressure	-	-	35 in (889 mm) WC	-	-	35 in (889 mm) WC
Fuel Supply Connection	5/16 in. SAE J1231 Type 1	1/4 in. SAE J1231 Type 1	1/4 in. SAE J1231 Type 1	5/16 in. SAE J1231 Type 1	1/4 in. SAE J1231 Type 1	1/4 in. SAE J1231 Type 1
Fuel Return Connection	1/4 in. SAE J1231 Type 1	-	-	1/4 in. SAE J1231 Type 1	-	-
Noise dB(A) ²	66	67	75	66	67	75
Weight	290 lb (132 Kg)	290 lb (132 Kg)	239 lb (107 Kg)	279 lb (127 Kg)	279 lb (127 Kg)	228 lb (104 Kg)
Compartment (H x D x W) ³	HGJAA/HGJAB: 17.2 in x 23.2 in x 34.6 in (438 mm x 589 mm x 879 mm) HGJAC: 16.5 in x 22.8 in x 27.9 in (420 mm x 579 mm x 709 mm)					
1. Sequential Multiport Fuel Injection 2. Measurements @ 10 ft (3 m) in a typical RV installation, under a 4 kW load. 3. With 1/2 in. clearances. See the Installation Manual for additional considerations when sizing the genset compartment.						

	LPG MODELS					
	6.5 HGJAA	6.5 HGJAB	6.5 HGJAC	5.5 HGJAA	5.5 HGJAB	5.5 HGJAC
GENERATOR: 2-Pole Revolving Field, 2-Bearing, Self-Excited, 1-Phase, Vertical Shaft, Capped Digital Voltage Regulation						
Power	6500 watts			5500 watts		
Frequency	60 Hertz			60 Hertz		
Voltage	120 volts			120 volts		
Current	54.2 amp			45.8 amp		
Speed	3600 rpm			3600 rpm		
FUEL CONSUMPTION:						
No load	2.2 lbs/h (1.0 kg/h)	2.2 lbs/h (1.0 kg/h)	2.2 lbs/h (1.0 kg/h)	1.8 lbs/h (0.8 kg/h)	1.8 lbs/h (0.8 kg/h)	1.8 lbs/h (0.8 kg/h)
Half load	3.9 lbs/h (1.8 kg/h)	3.9 lbs/h (1.8 kg/h)	3.9 lbs/h (1.8 kg/h)	3.3 lbs/h (1.5 kg/h)	3.3 lbs/h (1.5 kg/h)	3.3 lbs/h (1.5 kg/h)
Full load	5.3 lbs/h (2.4 kg/h)	5.3 lbs/h (2.4 kg/h)	5.3 lbs/h (2.4 kg/h)	4.6 lbs/h (2.1 kg/h)	4.6 lbs/h (2.1 kg/h)	4.6 lbs/h (2.1 kg/h)

	LPG MODELS					
	6.5 HGJAA	6.5 HGJAB	6.5 HGJAC	5.5 HGJAA	5.5 HGJAB	5.5 HGJAC
ENGINE: Air-Cooled, 4-Cycle Spark-Ignited, OHV, 90° V Twin Cyl, Vertical Shaft						
Fueling Method	Air/Fuel Mixer			Air/Fuel Mixer		
Governor	Mechanical			Mechanical		
Speed	2880 rpm			2400 rpm		
Bore	3.15 in (80 mm)			3.15 in (80 mm)		
Stroke	2.56 in (65 mm)			2.56 in (65 mm)		
Displacement	39.8 in ³ (653 cc)			39.8 in ³ (653 cc)		
Comp. Ratio	8.0 : 1			8.0 : 1		
Cyl. Comp. Test	153-188 psi			153-188 psi		
Oil Capacity	2.0 quart (1.8 l)			2.0 quart (1.8 l)		
Valve Lash (Cold)	0.004 in (0.10 mm), Intake & Exhaust			0.004 in (0.10 mm), Intake & Exhaust		
Spark Plug	18-25 lbs-ft (23-32 N-m)			18-25 lbs-ft (23-32 N-m)		
Ignition Timing	20° BTDC, non-adjustable magneto			20° BTDC, non-adjustable magneto		
Magneto Air Gap	0.012 in (0.3 mm)			0.012 in (0.3 mm)		
Spark Plug Gap	0.025 in (0.6-0.7 mm)			0.025 in (0.6-0.7 mm)		
DC SYSTEM:						
Battery Voltage	12 volts			12 volts		
Min. Battery CCA	450 @ 0° F (-18° C)			450 @ 0° F (-18° C)		
INSTALLATION:						
Exhaust O. D.	1-1/4 in			1-1/4 in		
Max. Exhaust Back Pressure	-	-	35 in (889 mm) WC	-	-	35 in (889 mm) WC
LPG Vapor: Connection Pressure	3/8-18 NPTF 9-13 in (228-330 mm) WC			3/8-18 NPTF 9-13 in (228-330 mm) WC		
LPG Liquid: Connection Pressure	1/4-18 NPTF Tank Pressure			1/4-18 NPTF Tank Pressure		
Noise dB(A) ¹	66	67	75	66	67	75
Weight	290 lb (132 Kg)	290 lb (132 Kg)	239 lb (107 Kg)	279 lb (127 Kg)	279 lb (127 Kg)	228 lb (104 Kg)
Compartment (H x D x W) ²	HGJAA/HGJAB: 17.2 in x 23.2 in x 34.6 in (438 mm x 589 mm x 879 mm) HGJAC: 16.5 in x 22.8 in x 27.9 in (420 mm x 579 mm x 709 mm)					
1. Measurements @ 10 ft (3 m) in a typical RV installation, under a 4 kW load. 2. With 1/2 in. clearances. See the Installation Manual for additional considerations when sizing the genset compartment.						

	GASOLINE MODELS					
	7.0 HGJAD	7.0 HGJAE	7.0 HGJAF	5.5 HGJAD	5.5 HGJAE	5.5 HGJAF
GENERATOR: 2-Pole Revolving Field, 2-Bearing, Self-Excited, 1-Phase, Vertical Shaft, Capped Digital Voltage Regulation						
Power (1.0 PF) ¹	7000 watts			5500 watts		
Frequency	60 Hertz			60 Hertz		
1-Ph, 4-Wire V/A	120 / 240 Volts, 29.2 Amps			120 / 240 Volts, 22.9 Amps		
1-Ph, 2-Wire V/A	120 Volts, 58.3 Amps			120 Volts, 45.8 Amps		
3-Ph V/A	120 / 240 Volts, 16.8 Amps			120 / 240 Volts, 12 Amps		
Speed	3600 rpm			3600 rpm		
FUEL CONSUMPTION:						
No load	0.43 gph (1.6 l/h)	0.43 gph (1.6 l/h)	0.43 gph (1.6 l/h)	0.34 gph (1.3 l/h)	0.35 gph (1.3 l/h)	0.35 gph (1.3 l/h)
Half load	0.70 gph (2.7 l/h)	0.73 gph (2.8 l/h)	0.73 gph (2.8 l/h)	0.58 gph (2.2 l/h)	0.60 gph (2.3 l/h)	0.60 gph (2.3 l/h)
Full load	1.13 gph (4.3 l/h)	1.22 gph (4.6 l/h)	1.22 gph (4.6 l/h)	0.89 gph (3.4 l/h)	0.95 gph (3.6 l/h)	0.95 gph (3.6 l/h)
ENGINE: Air-Cooled, 4-Cycle Spark-Ignited, OHV, 90° V Twin Cyl, Vertical Shaft						
Fueling Method	SFI ²	Carburetor	Carburetor	SFI ²	Carburetor	Carburetor
Governor	Digital	Mechanical	Mechanical	Digital	Mechanical	Mechanical
Speed	2880 rpm			2400 rpm		
Bore	3.15 in (80 mm)			3.15 in (80 mm)		
Stroke	2.56 in (65 mm)			2.56 in (65 mm)		
Displacement	39.8 in ³ (653 cc)			39.8 in ³ (653 cc)		
Comp. Ratio	8.0 : 1			8.0 : 1		
Cyl. Comp. Test	153-188 psii			153-188 psii		
Oil Capacity	2.0 quart (1.8 l)			2.0 quart (1.8 l)		
Valve Lash (Cold)	0.004 in (0.10 mm), Intake & Exhaust			0.004 in (0.10 mm), Intake & Exhaust		
Spark Plug	18-25 lbs-ft (23-32 N-m)			18-25 lbs-ft (23-32 N-m)		
Ignition Timing	20° BTDC, non-adjustable magneto			20° BTDC, non-adjustable magneto		
Magneto Air Gap	0.012 in (0.3 mm)			0.012 in (0.3 mm)		
Spark Plug Gap	0.025 in (6-7 mm)			0.025 in (6-7 mm)		
HYDRAULIC PUMP:	Fixed-displacement gear pump—1.8 gpm @ 2500 psi			Fixed-displacement gear pump—1.6 gpm @ 2500 psi		
DC SYSTEM:						
Battery Voltage	12 volts			12 volts		

	GASOLINE MODELS					
	7.0 HGJAD	7.0 HGJAE	7.0 HGJAF	5.5 HGJAD	5.5 HGJAE	5.5 HGJAF
Battery Charging	10 amps regulated			10 amps regulated		
Min. Battery CCA	450 @ 0° F (-18° C)			450 @ 0° F (-18° C)		
INSTALLATION:						
Exhaust O. D.	1-1/4 in			1-1/4 in		
Max. Exhaust Back Pressure	-	-	35 in (889 mm) WC	-	-	35 in (889 mm) WC
Fuel Supply Connection	5/16 in. SAE J1231 Type 1	1/4 in. SAE J1231 Type 1	1/4 in. SAE J1231 Type 1	5/16 in. SAE J1231 Type 1	1/4 in. SAE J1231 Type 1	1/4 in. SAE J1231 Type 1
Fuel Return Connection	5/16 in. SAE J1231 Type 1	-	-	5/16 in. SAE J1231 Type 1	-	-
Hydraulic Fluid	Transmission or Petroleum-Based Hydraulic Fluid—Operating Viscosity: 80-1000 SSU—Maximum Start-Up Viscosity: 4000 SSU			Transmission or Petroleum-Based Hydraulic Fluid—Operating Viscosity: 80-1000 SSU—Maximum Start-Up Viscosity: 4000 SSU		
Hydraulic Pump Inlet Conditions	Not to exceed 5 in Hg Vacuum or 20 psi Pressure			Not to exceed 5 in Hg Vacuum or 20 psi Pressure		
Hydraulic Pump Connections Outlet Inlet	3/4-16 UNF-2B SAE 7/8-14 UNF-2B SAE			3/4-16 UNF-2B SAE 7/8-14 UNF-2B SAE		
Noise dB(A) ³	66	67	75	66	67	75
Weight	290 lb (132 Kg)	290 lb (132 Kg)	239 lb (107 Kg)	279 lb (127 Kg)	279 lb (127 Kg)	228 lb (104 Kg)
Compartment (H x D x W) ⁴	HGJAD/HGJAE: 17.2 in x 23.2 in x 34.6 in (438 mm x 589 mm x 879 mm) HGJAF: 16.5 in x 22.8 in x 27.9 in (420 mm x 579 mm x 709 mm)					
<p>1. A genset with a hydraulic pump is rated with the pump idle.</p> <p>2. Sequential Multiport Fuel Injection</p> <p>3. Measurements @ 10 ft (3 m) in a typical installation, under a 4 kW load.</p> <p>4. With 1/2 in. clearances. See the Installation Manual for additional considerations when sizing the genset compartment.</p>						

	LPG MODELS			
	6.5 HGJAE	6.5 HGJAF	5.5 HGJAE	5.5 HGJAF
GENERATOR: 2-Pole Revolving Field, 2-Bearing, Self-Excited, 1-Phase, Vertical Shaft, Capped Digital Voltage Regulation				
Power (1.0 PF) ¹	6500 watts		5500 watts	
Frequency	60 Hertz		60 Hertz	
1-Ph, 4-Wire V/A	120 / 240 Volts, 27 Amps		120 / 240 Volts, 22.9 Amps	
Speed	3600 rpm		3600 rpm	
FUEL CONSUMPTION:				

	LPG MODELS			
	6.5 HGJAE	6.5 HGJAF	5.5 HGJAE	5.5 HGJAF
No load	2.2 lbs/h (1.0 kg/h)	2.2 lbs/h (1.0 kg/h)	1.8 lbs/h (0.8 kg/h)	1.8 lbs/h (0.8 kg/h)
Half load	3.9 lbs/h (1.8 kg/h)	3.9 lbs/h (1.8 kg/h)	3.3 lbs/h (1.5 kg/h)	3.3 lbs/h (1.5 kg/h)
Full load	5.3 lbs/h (2.4 kg/h)	5.3 lbs/h (2.4 kg/h)	4.6 lbs/h (2.1 kg/h)	4.6 lbs/h (2.1 kg/h)
ENGINE: Air-Cooled, 4-Cycle Spark-Ignited, OHV, 90° V Twin Cyl, Vertical Shaft				
Fueling Method	Air/Fuel Mixer		Air/Fuel Mixer	
Governor	Mechanical		Mechanical	
Speed	2880 rpm		2400 rpm	
Bore	3.15 in (80 mm)		3.15 in (80 mm)	
Stroke	2.56 in (65 mm)		2.56 in (65 mm)	
Displacement	39.8 in ³ (653 cc)		39.8 in ³ (653 cc)	
Comp. Ratio	8.0 : 1		8.0 : 1	
Cyl. Comp. Test	153-188 psi		153-188 psi	
Oil Capacity	2.0 quart (1.8 l)		2.0 quart (1.8 l)	
Valve Lash (Cold)	0.004 in (0.10 mm), Intake & Exhaust		0.004 in (0.10 mm), Intake & Exhaust	
Spark Plug	18-25 lbs-ft (23-32 N-m)		18-25 lbs-ft (23-32 N-m)	
Ignition Timing	20° BTDC, non-adjustable magneto		20° BTDC, non-adjustable magneto	
Magneto Air Gap	0.012 in (0.3 mm)		0.012 in (0.3 mm)	
Spark Plug Gap	0.025 in (6-7 mm)		0.025 in (6-7 mm)	
HYDRAULIC PUMP:	Fixed-displacement gear pump—1.8 gpm @ 2500 psi		Fixed-displacement gear pump—1.6 gpm @ 2500 psi	
DC SYSTEM:				
Battery Voltage	12 volts		12 volts	
Battery Charging	10 amps regulated		10 amps regulated	
Min. Battery CCA	450 @ 0° F (-18° C)		450 @ 0° F (-18° C)	
INSTALLATION:				
Exhaust O. D.	1-1/4 in		1-1/4 in	
Max. Exhaust Back Pressure	-	35 in (889 mm) WC	-	35 in (889 mm) WC
LPG Vapor: Connection Pressure	3/8-18 NPTF 9-13 in (228-330 mm) WC		3/8-18 NPTF 9-13 in (228-330 mm) WC	
LPG Liquid: Connection Pressure	1/4-18 NPTF Tank Pressure		1/4-18 NPTF Tank Pressure	

	LPG MODELS			
	6.5 HGJAE	6.5 HGJAF	5.5 HGJAE	5.5 HGJAF
Hydraulic Fluid	Transmission or Petroleum-Based Hydraulic Fluid—Operating Viscosity: 80-1000 SSU—Maximum Start-Up Viscosity: 4000 SSU		Transmission or Petroleum-Based Hydraulic Fluid—Operating Viscosity: 80-1000 SSU—Maximum Start-Up Viscosity: 4000 SSU	
Hydraulic Pump Inlet Conditions	Not to exceed 5 in Hg Vacuum or 20 psi Pressure		Not to exceed 5 in Hg Vacuum or 20 psi Pressure	
Hydraulic Pump Connections Outlet Inlet	3/4-16 UNF-2B SAE 7/8-14 UNF-2B SAE		3/4-16 UNF-2B SAE 7/8-14 UNF-2B SAE	
Noise dB(A) ²	67	75	67	75
Weight	290 lb (132 Kg)	239 lb (107 Kg)	279 lb (127 Kg)	228 lb (104 Kg)
Compartment (H x D x W) ³	HGJAD/HGJAE: 17.2 in x 23.2 in x 34.6 in (438 mm x 589 mm x 879 mm) HGJAF: 16.5 in x 22.8 in x 27.9 in (420 mm x 579 mm x 709 mm)			
<p>1. A genset with a hydraulic pump is rated with the pump idle.</p> <p>2. Measurements @ 10 ft (3 m) in a typical installation, under a 4 kW load.</p> <p>3. With 1/2 in. clearances. See the Installation Manual for additional considerations when sizing the genset compartment.</p>				

This page is intentionally blank.

15 Torque Specifications

	lb-ft*	Nm*
Spark Plugs	10 (New), 18 (Reused)	13 (New), 24 (Reused)
Generator Set Mounting Screws	35	48
Generator Set Through Bolts	8	11
Belt Tensioner Center Bolt	20	26
Generator Set Pulley Center Bolt	45	61
Fan Screws	8	11
Flywheel to Pulley Coupling Nuts	5	6
Flywheel Center Bolt	60	81
Magneto Mounting Screws	5	7
Exhaust Manifold Flange Nuts	20	26
Fan Shroud Screws	8	11
Muffler Flange Nuts	10	13
Intake Manifold Bolts	19	26
Throttle Body/Carburetor/Mixer Mounting Nuts	4.5	6
Fuel Rail Mounting Screws (EFI)	75 lb-inch	8.4
Throttle Body Stator Screws (EFI)	18 lb-inch	2
LPG Inlet Filter	25	34
Governor Arm Shaft Nut (Counterclockwise)	8	11
Alternator/Engine Assembly Fail Safe Bolts	38	51
Engine Mounting Screws	20	26
Cylinder Shroud Screws	8	11
Starter Motor Mounting Screws	20	26
Starter Terminal Nut	6.5	8
Valve Lash Adjustment Lock Nuts	6.5	8
Valve Cover Screws	5.5	8
Cylinder Head Bolts (Three equal increments)	24.6-30.4	33.3-41.2
Engine Breather Valve Cover Screws	3	4
Connecting Rod Cap Bolts	16.3-19.9	22.1-27.0
Crankcase Cover Screws	16.2-16.9	22-23
Hydraulic Pump Mounting Flange Bolts	20	26
* -Use engine oil as a lubricant for all threads except when otherwise specified.		

This page is intentionally blank.

Appendix A. Wiring Diagrams

Table of Contents

Figure 79. Wiring Diagram 611-1272 - HGJAA	185
Figure 80. Wiring Harness 338-3609 - HGJAA	186
Figure 81. Wiring Diagram 611-1271 - HGJAB/HGJAC	187
Figure 82. Wiring Harness 338-3847 - HGJAB/HGJAC	188
Figure 83. Wiring Diagram 611-1274 - HGJAD	189
Figure 84. Wiring Harness 338-3927 - HGJAD	190
Figure 85. Wiring Diagram 611-1273 - HGJAE/HGJAF	191
Figure 86. Wiring Harness 338-3609 - HGJAE/HGJAF	192

This page is intentionally blank.

A.0 Wiring Diagrams

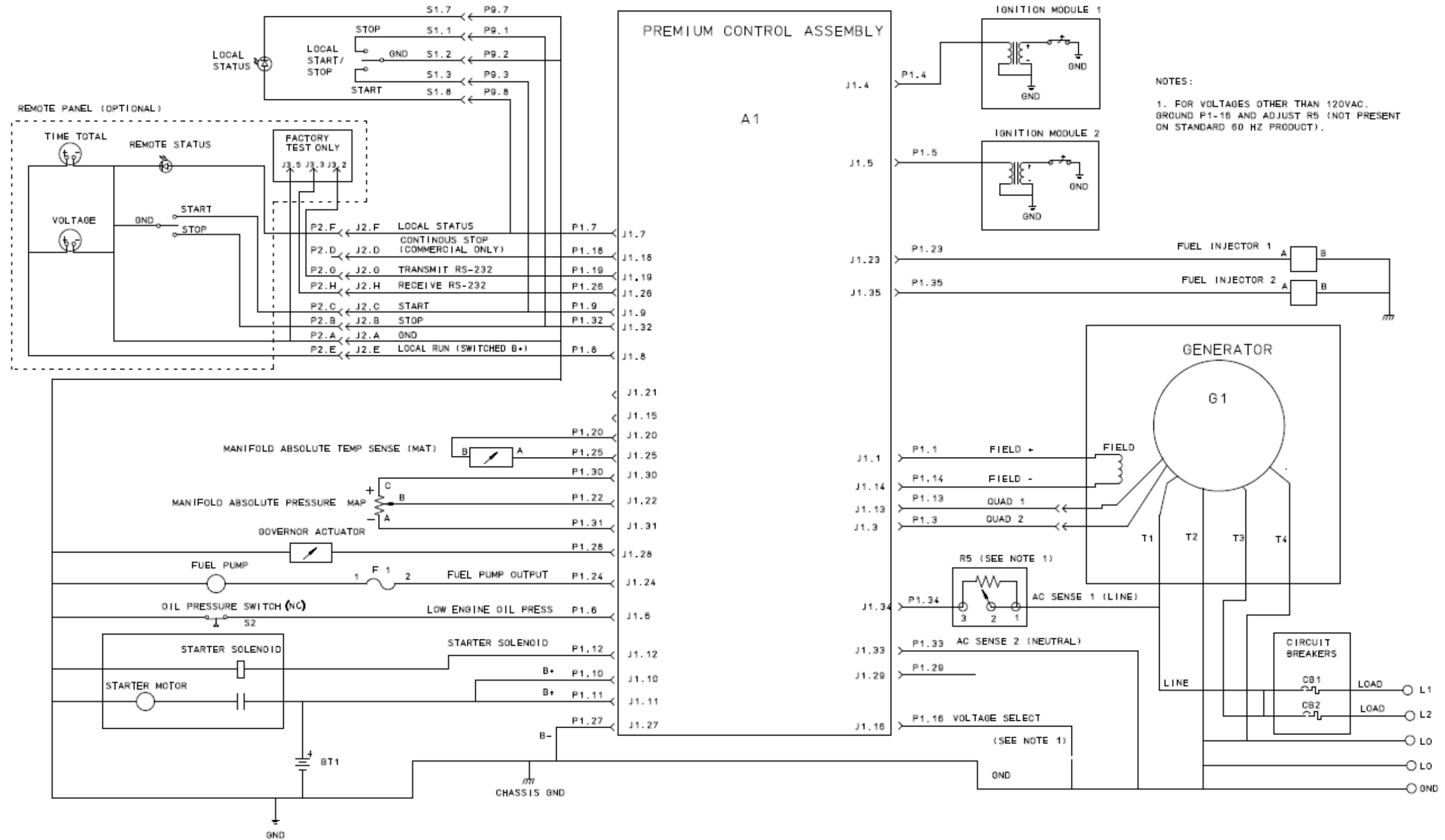

FIGURE 79. WIRING DIAGRAM 611-1272 - HGJAA

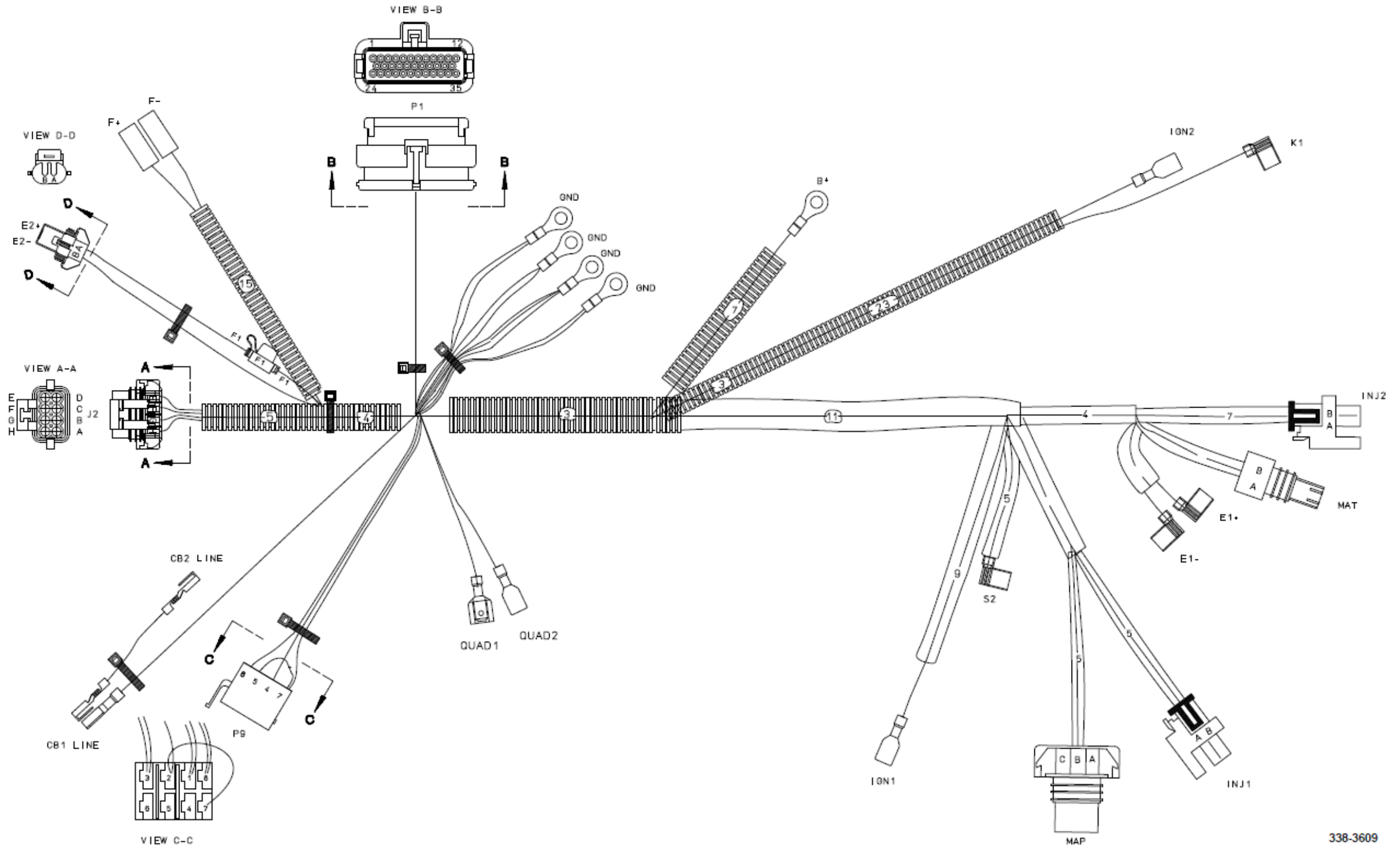
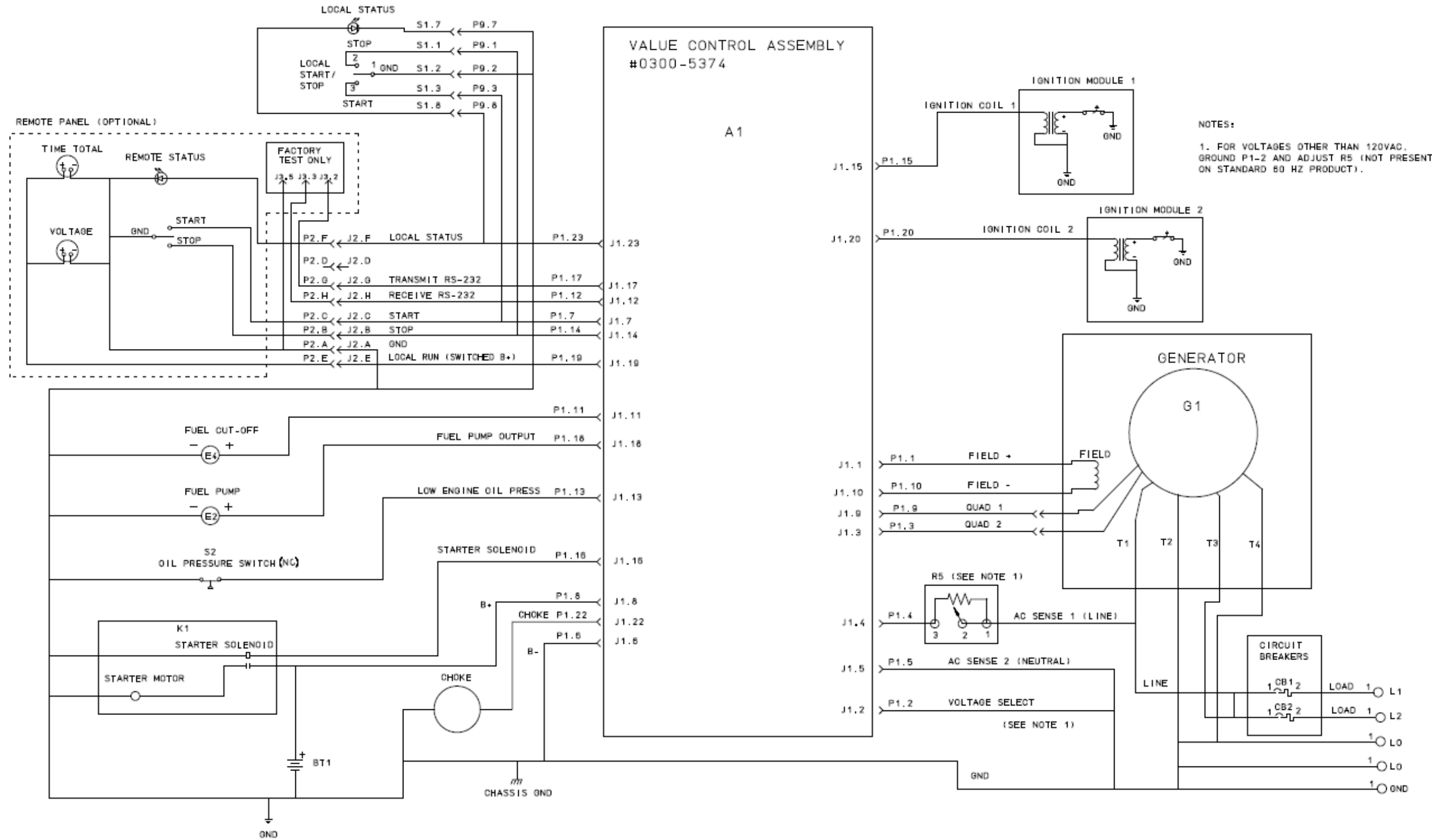
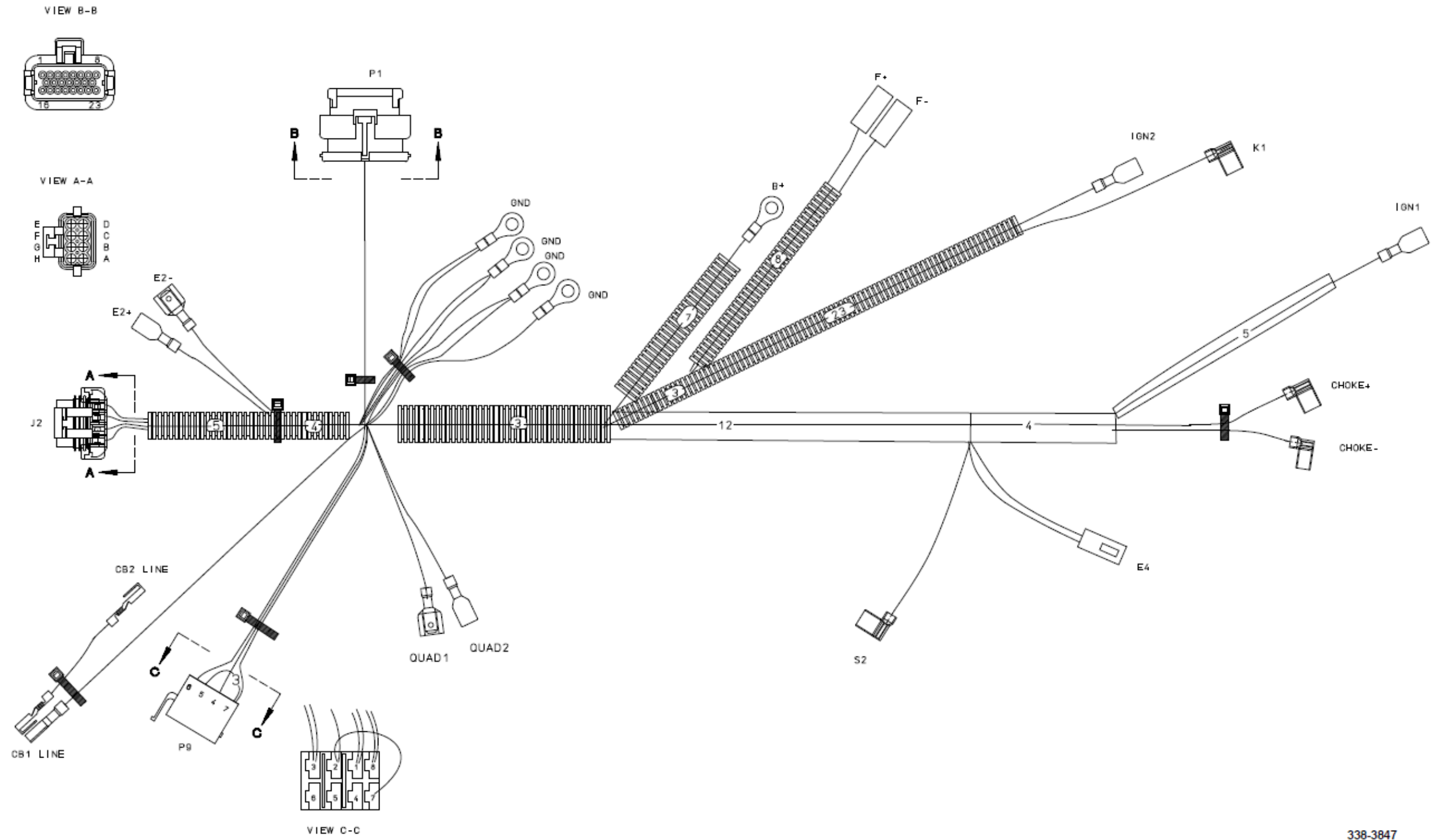

FIGURE 80. WIRING HARNESS 338-3609 - HGJAA



611-1271

FIGURE 81. WIRING DIAGRAM 611-1271 - HGJAB/HGJAC



338-3847

WIRING HARNESS—HGJAB/HGJAC

FIGURE 82. WIRING HARNESS 338-3847 - HGJAB/HGJAC

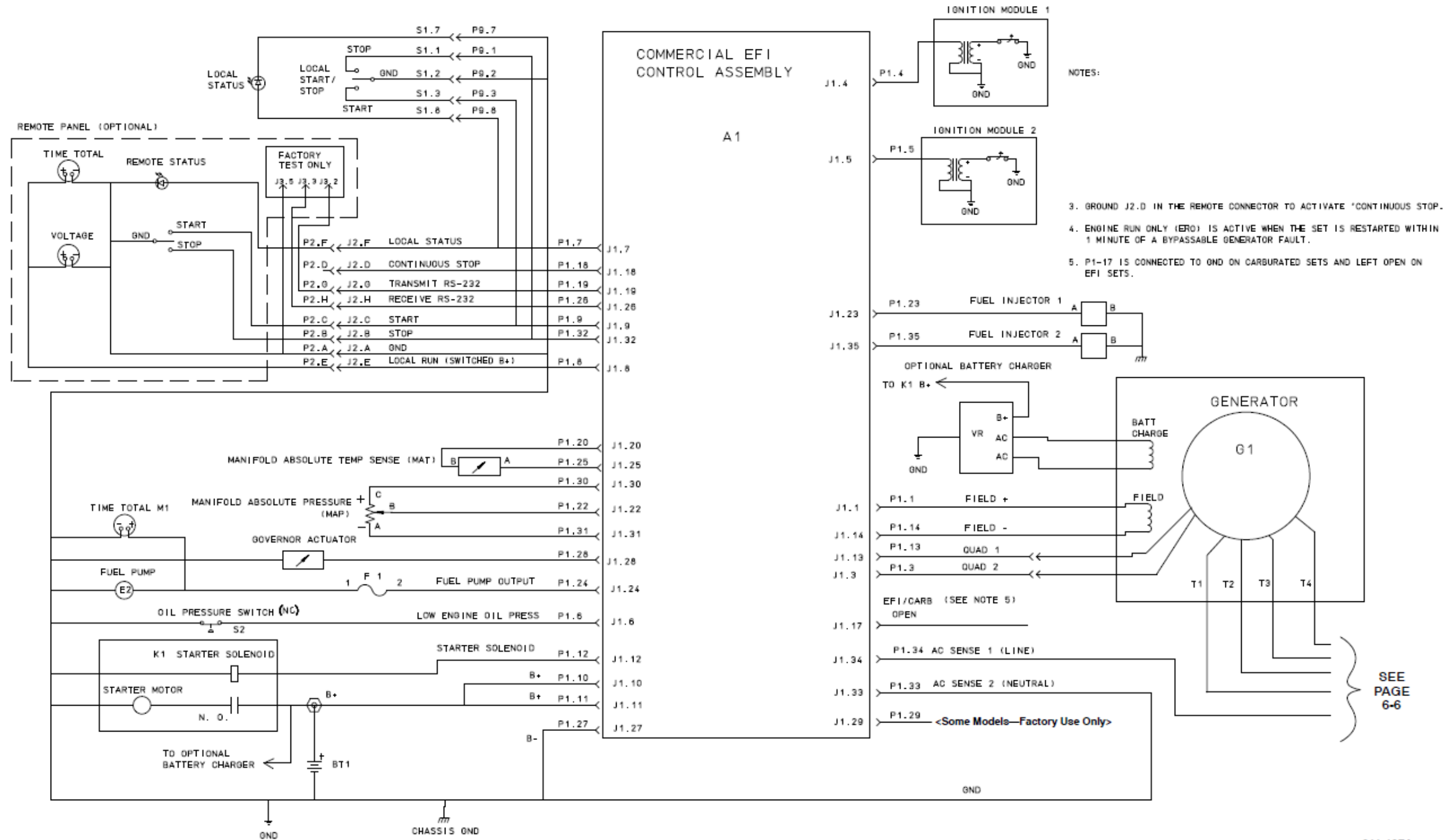

611-1274

FIGURE 83. WIRING DIAGRAM 611-1274 - HGJAD

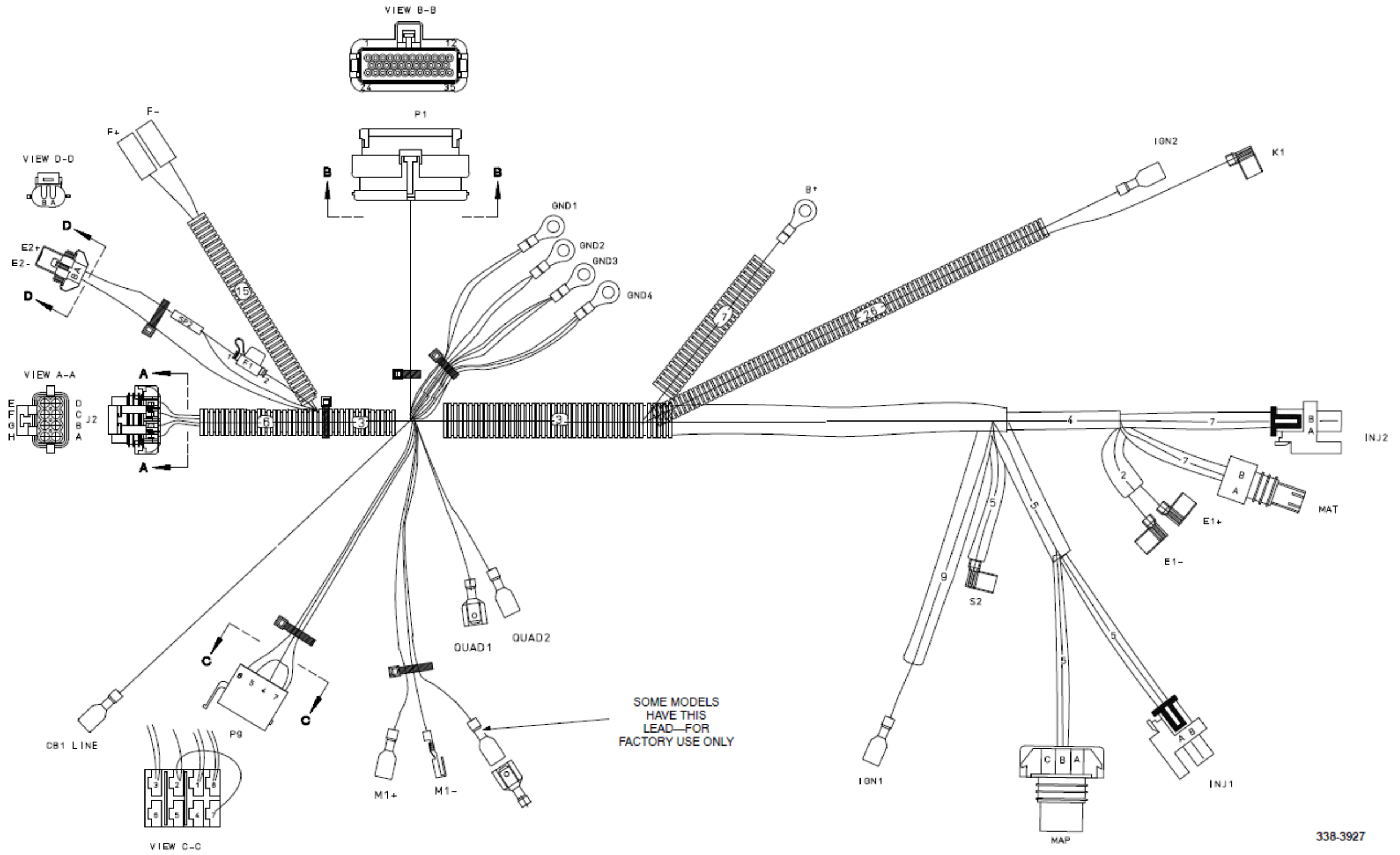

FIGURE 84. WIRING HARNESS 338-3927 - HGJAD

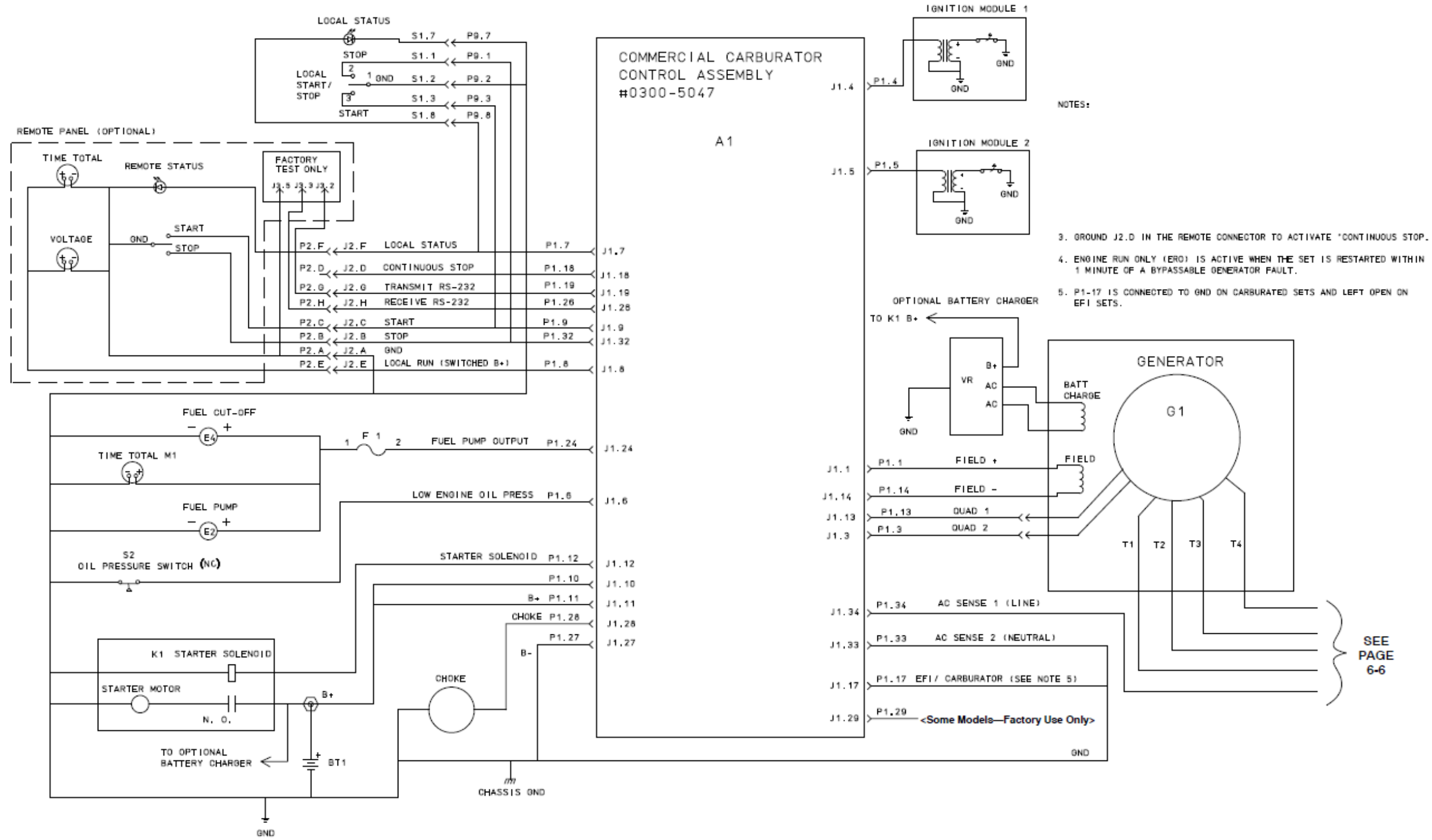
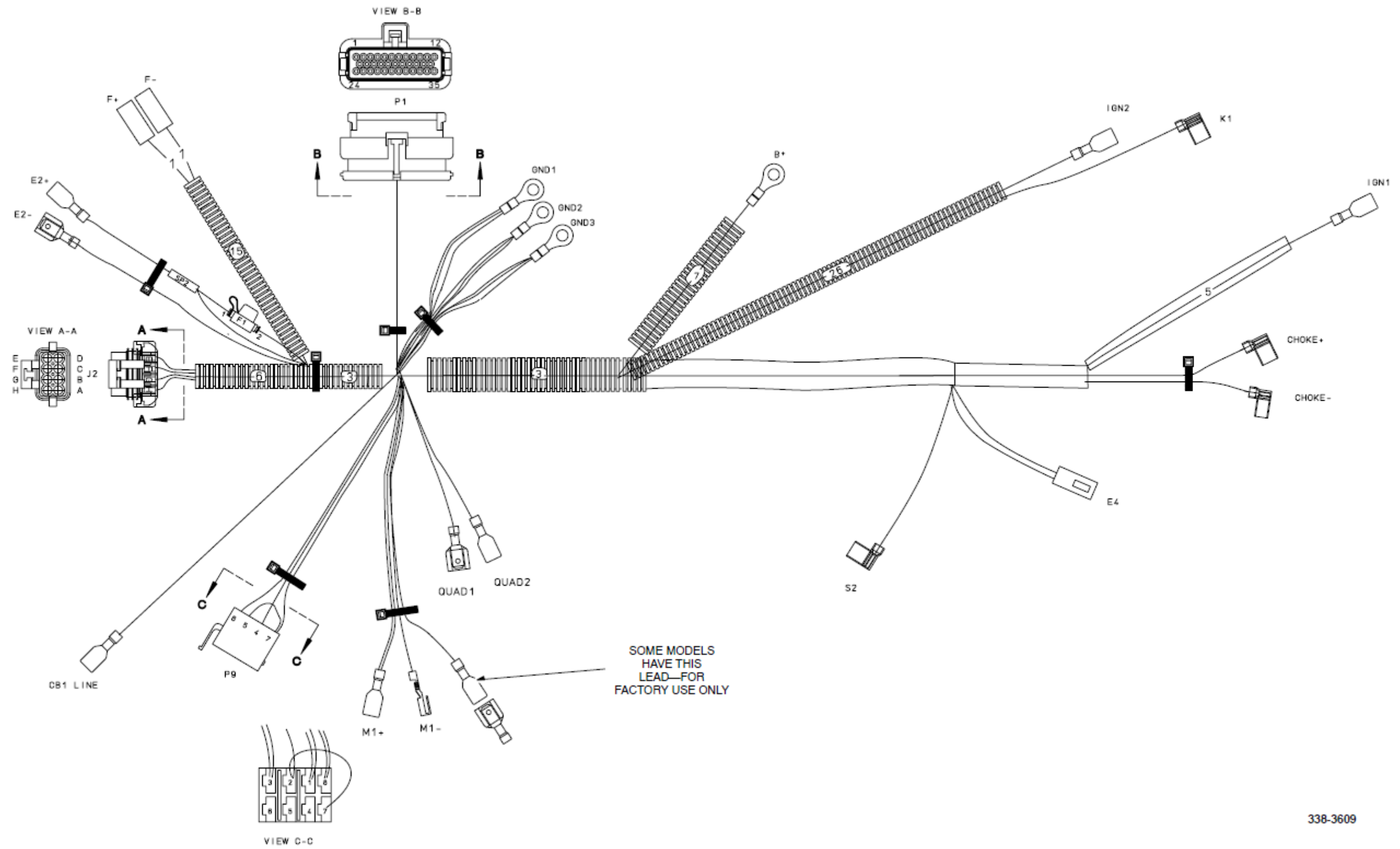

FIGURE 85. WIRING DIAGRAM 611-1273 - HGJAE/HGJAF

611-1273



338-3609

FIGURE 86. WIRING HARNESS 338-3609 - HGJAE/HGJAF

power.cummins.com

Copyright © 2018 Cummins Inc. All rights reserved.

Cummins, Onan, and the "C" logo are registered trademarks of Cummins Inc. and its subsidiaries.

Other company, product, or service names may be trademarks or service marks of others.

Specifications are subject to change without notice.

