



# Service Manual

## Onan Generator Set for Commercial Mobile

HDKAL (Spec B–J)

HDKAQ (Spec A)

HDKAR (Spec A )

HDKAS (Spec B–E)



# Table of Contents

---

SECTION	TITLE	PAGE
	<b>SAFETY PRECAUTIONS</b> .....	iii
<b>1</b>	<b>INTRODUCTION</b> .....	1-1
	About This Manual .....	1-1
	Assistance .....	1-1
	Test Equipment .....	1-1
	Safety Considerations .....	1-1
	Set Removal .....	1-3
<b>2</b>	<b>ENGINE CONTROLS</b> .....	2-1
	General .....	2-1
	Start Control at Set .....	2-1
	Control Troubleshooting .....	2-6
<b>3</b>	<b>ENGINE CONTROL SERVICE</b> .....	3-1
	General .....	3-1
	[A] Battery Check (BT1) .....	3-1
	[B] Battery Cable Check .....	3-1
	[C] Battery Charging Check .....	3-1
	[D] Start Solenoid Check (K11) .....	3-1
	[E] Heater (Glow Plug) Relay Check (K13) .....	3-2
	[F] Fuel Solenoid Check (K14) .....	3-2
	[G] Start/Stop Switch Check (S11) .....	3-2
	[H] Power Relay Check (A11-K12) .....	3-2
<b>4</b>	<b>GENERATOR/VOLTAGE REGULATOR</b> .....	4-1
	General Description .....	4-1
	Generator Operation .....	4-5
	Electronic Voltage Regulator .....	4-5
	Generator Service .....	4-6
	Generator Disassembly/Assembly .....	4-8
<b>5</b>	<b>GENERATOR/REGULATOR TROUBLESHOOTING</b> .....	5-1
	General .....	5-1
	Troubleshooting Procedures .....	5-1

SECTION	TITLE	PAGE
6	<b>GENERATOR/REGULATOR TESTS</b> .....	6-1
	General .....	6-1
	[A] Testing Field Voltage .....	6-1
	[B] Testing Generator Rotor .....	6-1
	[C] Testing Generator Stator .....	6-2
	[D] Dynamic Rotor/Stator Test .....	6-3
	[E] Voltage Regulator Replacement .....	6-5
	[F] Wiring Harness Check .....	6-5
	[G] Voltage Adjustment .....	6-5
	[H] Reconnection .....	6-5
7	<b>PERIODIC MAINTENANCE</b> .....	7-1
	General Inspection .....	7-2
	Changing Oil and Oil Filter .....	7-3
	Air Cleaner Maintenance .....	7-4
	Spark Arrestor Cleaning .....	7-4
	Batteries .....	7-4
	Engine Cooling System .....	7-5
	Fuel System .....	7-7
	Bio-Diesel Fuels B5-B20 .....	7-9
	<b>DC CONTROL WIRING DIAGRAMS</b> .....	A-1
	<b>SINGLE-PHASE GENERATOR DIAGRAMS</b> .....	A-2
	<b>THREE-PHASE GENERATOR DIAGRAMS</b> .....	A-3

# Safety Precautions

---

Thoroughly read the OPERATOR'S MANUAL before operating the genset. Safe operation and top performance can be obtained only by proper operation and maintenance.

The following symbols in this Manual alert you to potential hazards to the operator, service personnel and equipment.

**⚠ DANGER** alerts you to an immediate hazard which will result in severe personal injury or death.

**⚠ WARNING** alerts you to a hazard or unsafe practice which can result in severe personal injury or death.

**⚠ CAUTION** alerts you to a hazard or unsafe practice which can result in personal injury or equipment damage.

Electricity, fuel, exhaust, moving parts and batteries present hazards which can result in severe personal injury or death.

## GENERAL PRECAUTIONS

- Keep ABC fire extinguishers handy.
- Make sure all fasteners are secure and torqued properly.
- Keep the genset and its compartment clean. Excess oil and oily rags can catch fire. Dirt and gear stowed in the compartment can restrict cooling air.
- Let the engine cool down before removing the coolant pressure cap or opening the coolant drain. Hot coolant under pressure can spray out and cause severe burns.
- Before working on the genset, disconnect the negative (-) battery cable at the battery to prevent starting.
- Use caution when making adjustments while the genset is running—hot, moving or electrically

live parts can cause severe personal injury or death.

- Used engine oil has been identified by some state and federal agencies as causing cancer or reproductive toxicity. Do not ingest, inhale, or contact used oil or its vapors.
- Do not work on the genset when mentally or physically fatigued or after consuming alcohol or drugs.
- Carefully follow all applicable local, state and federal codes.

## GENERATOR VOLTAGE IS DEADLY!

- Generator output connections must be made by a qualified electrician in accordance with applicable codes.
- The genset must not be connected to the public utility or any other source of electrical power. Connection could lead to electrocution of utility workers, damage to equipment and fire. An approved switching device must be used to prevent interconnections.
- Use caution when working on live electrical equipment. Remove jewelry, make sure clothing and shoes are dry and stand on a dry wooden platform on the ground or floor.

## FUEL IS FLAMMABLE AND EXPLOSIVE

- Keep flames, cigarettes, sparks, pilot lights, electrical arc-producing equipment and switches and all other sources of ignition well away from areas where fuel fumes are present and areas sharing ventilation.
- Fuel lines must be secured, free of leaks and separated or shielded from electrical wiring.
- Use approved non-conductive flexible fuel hose for fuel connections at the genset.

## ENGINE EXHAUST IS DEADLY!

- Learn the symptoms of carbon monoxide poisoning in this manual.
- Never sleep in the vehicle while the genset is running unless the vehicle has a working carbon monoxide detector.
- The exhaust system must be installed in accordance with the genset Installation Manual.
- Do not use engine cooling air to heat the vehicle interior.
- Make sure there is ample fresh air when operating the genset in a confined area.

## MOVING PARTS CAN CAUSE SEVERE PERSONAL INJURY OR DEATH

- Do not wear loose clothing or jewelry near moving parts such as PTO shafts, fans, belts and pulleys.
- Keep hands away from moving parts.

- Keep guards in place over fans, belts, pulleys, etc.

## BATTERY GAS IS EXPLOSIVE

- Wear safety glasses and do not smoke while servicing batteries.
- When disconnecting or reconnecting battery cables, always disconnect the negative (-) battery cable first and reconnect it last to reduce arcing.

## DO NOT OPERATE IN FLAMMABLE AND EXPLOSIVE ENVIRONMENTS

Flammable vapor can cause a diesel engine to overspeed and become difficult to stop, resulting in possible fire, explosion, severe personal injury and death. ***Do not operate a diesel-powered genset where a flammable vapor environment can be created by fuel spill, leak, etc., unless the genset is equipped with an automatic safety device to block the air intake and stop the engine.*** The owners and operators of the genset are solely responsible for operating the genset safely. Contact your authorized Cummins dealer or distributor for more information.

# 1. Introduction

---

## ABOUT THIS MANUAL

This manual contains troubleshooting and repair data for these components of the HDKAL/HDKAQ/HDKAR/HDKAS generator set:

- Control
- generator set

See the Engine Service Manual for engine information.

Study this manual carefully. Heed all warnings and cautions. Proper use and maintenance can result in longer set life, better performance and safer operation.

This manual contains basic wiring diagrams and schematics for troubleshooting. Technicians should use the wiring diagram and schematic shipped with each unit. Update these diagrams and schematics when the set is modified.

PC board information is limited; in the field, it is more efficient to replace the boards than to attempt repair.

## ASSISTANCE

When contacting a Cummins distributor, supply the complete model number and serial number shown on the Cummins nameplate on the side of the generator set.

## TEST EQUIPMENT

- Multimeter/digital VOM
- AC voltmeter
- DC voltmeter
- Frequency meter
- Jumper leads
- Load test panel
- Megger or insulation resistance meter
- Wheatstone bridge or digital ohmmeter
- Harness Kit for InPower Diagnostic Service Tool (0541-1287)
- Harness Kit for InPower Diagnostic Service Tool (0541-1374)
- Harness Kit for InPower Diagnostic Service Tool (0541-1389)

**⚠WARNING** *Incorrect service or replacement of parts can result in severe personal injury, death, and /or equipment damage. Service personnel must be qualified to perform electrical and mechanical service.*

## SAFETY CONSIDERATIONS

generator sets present safety hazards that the technician must know about. Read the precautions on the inside cover of this manual. Familiarize yourself with the hazards shown in Table 1-1. When the hazards are known, approach the job with a safety-conscious attitude. Being safety-conscious is the best way to avoid injury. **Reduce the chance of an accident with the following safeguards.**

### Safeguards To Avoid Hazards

- **Use Protective Clothing.** Protect your body by wearing protective clothing such as:
  - Safety shoes
  - Gloves
  - Safety glasses
  - Hard hats

Leave rings and jewelry off. Do not wear loose clothing that might get caught on equipment.

- **Reduce Workshop Hazards.**
  - Keep guards and shields in place on machinery
  - Maintain equipment in good working order
  - Store flammable liquids in approved containers away from open flame, spark, pilot light, cigarette, or other ignition source
  - Keep the workshop clean and well-lighted
  - Provide adequate ventilation
  - Keep a fire extinguisher and safety equipment nearby
  - Be prepared to respond to an emergency
- **Develop Safe Work Habits.**

Unsafe actions are the source of most accidents with tools and machines. Be familiar with the equipment and know how to use it safely. Use the right tool for the job, and check its condition before starting. Observe the warnings and cautions in this manual and take special

precautions when working around electrical equipment. Do not work alone if possible and do not take unnecessary risks.

- **Be prepared if an accident occurs.**

Agencies such as the Red Cross and local police and fire departments offer courses in first

aid, CPR, and fire control. Take advantage of this information to be ready to respond to an accident. Learn to be safety conscious and make safe practices a part of your work routine. Do not work when tired or after consuming any alcohol or drug that makes the operation of equipment unsafe.

**TABLE 1-1. HAZARDS AND THEIR SOURCES**

<ul style="list-style-type: none"> <li>• <b>Fire and explosions</b> <ul style="list-style-type: none"> <li>• Leaking fuel</li> <li>• Hydrogen gas from charging battery</li> <li>• Oily rags improperly stored</li> <li>• Flammable liquids improperly stored</li> <li>• Any fire, flame, spark, pilot light, arc-producing equipment or other ignition sources</li> </ul> </li> <li>• <b>Burns</b> <ul style="list-style-type: none"> <li>• Hot exhaust pipes</li> <li>• Hot engine and generator set surfaces</li> <li>• Hot engine oil</li> <li>• Electrical short in DC wiring system</li> <li>• Hot engine coolant</li> </ul> </li> <li>• <b>Poisonous gases</b> <ul style="list-style-type: none"> <li>• Carbon monoxide from faulty exhaust pipes, joints or hangers</li> <li>• Operating generator set where exhaust gases can accumulate</li> </ul> </li> </ul>	<ul style="list-style-type: none"> <li>• <b>Electrical shock (AC)</b> <ul style="list-style-type: none"> <li>• Improper generator set load connections</li> <li>• Faulty RV wiring</li> <li>• Faulty electrical appliance</li> <li>• Faulty generator set wiring</li> <li>• Working in damp conditions</li> <li>• Jewelry touching electrical components</li> </ul> </li> <li>• <b>Rotating Machinery</b> <ul style="list-style-type: none"> <li>• Flywheel fan guard not in place</li> <li>• Jewelry or loose clothing catching in moving parts</li> </ul> </li> <li>• <b>Slippery Surfaces</b> <ul style="list-style-type: none"> <li>• Leaking or spilled oil</li> </ul> </li> <li>• <b>Heavy Objects</b> <ul style="list-style-type: none"> <li>• Removing generator set from RV</li> <li>• Removing heavy components</li> </ul> </li> </ul>
--	--



## SET REMOVAL

Some service procedures require removing the generator set from the vehicle. Because of the wide variety of installations, it is not possible to specify exact removal procedures for each generator set. If a satisfactory method for removing a particular set cannot be determined, contact the vehicle manufacturer or the set installer for their recommendations.

**⚠WARNING** *generator set are heavy and they can cause severe personal injury or death if dropped during removal. Use adequate lifting devices to provide sufficient support for the set. Keep hands and feet clear while lifting the generator set. Before starting set removal, place the transmission in park, set the emergency brake, and remove the negative (-) cable from the vehicle ignition system battery to avoid inadvertent movement of the vehicle.*

### Disconnecting generator set Systems

Some installations require partial removal of the set to gain access to the battery cable, fuel line, and other connections. Read this entire section before starting set removal. The following steps are a general guideline.

**⚠WARNING** *Leakage of fuel in or around the generator set compartment presents the hazard of fire or explosion that can cause severe personal injury or death. Do not disconnect or connect battery cables if fuel vapors are present. Ventilate the compartment thoroughly: park vehicles outdoors in a well ventilated area.*

1. Disconnect the generator set negative (-) battery cable at the battery terminal.
2. Disconnect the generator set positive (+) battery cable from the starter solenoid.

3. Disconnect the remote control plug wire from the generator set (if applicable).
4. Disconnect the generator set load wires. Tag for identification when reconnecting.
5. Disconnect the exhaust system and support brackets or hangers, to allow set removal.
6. Disconnect the fuel line at the generator set fuel pump. Securely plug the end of the fuel line to prevent fuel leakage.
7. Verify that the set is adequately supported before loosening any mounting bolts or support members.

**⚠WARNING** *Leakage of fuel presents the hazard of fire or explosion that can cause severe personal injury or death. Make certain all fuel line openings are plugged. Before disconnecting the fuel line, be certain there are no ignition sources such as flame, spark, pilot light, cigarette, etc., near the generator set. Keep an ABC type fire extinguisher nearby.*

When reinstalling the set, be sure all mounting hardware, and electrical, exhaust, and fuel system components are connected exactly as they were before removal. See the appropriate installation manual during reinstallation for important safety precautions.

Check for oil and fuel leaks. Check the exhaust system audibly and visually with the generator set running. Repair leaks immediately. Replace worn, damaged, or corroded exhaust and fuel line components before leaks occur.

**THIS PAGE IS INTENDED TO BE BLANK**

## 2. Engine Controls

---

### GENERAL

This section describes the generator set preheat/start/run control system. The set may be started either at the onboard DC control box or by using a remotely mounted start control.

### START CONTROL AT SET

The set is started with a Start/Stop/Preheat switch on the front panel of the DC control box. Component references are found on wiring/schematic diagrams in the Wiring Diagrams section of this manual.

The DC control box does not contain meters and is designed for remote mounting within limits of the wire harness (approximately 32 inches [813 mm]). Optional extension harnesses are available from Cummins. An optional remote control panel with meters is also available in a kit from Cummins.

### Switches

**Start-Stop/Preheat Switch S11:** Starts and stops the unit locally. Preheat function occurs when the switch is held in the Stop position. The unit may also be operated from a remote switch wired to receptacle J3 on a pigtail out of the DC control box. On commercial HDKAL/HDKAS model, this switch has an environmental cover.

### Circuit Breakers

**DC Control Breaker CB11:** A 15 ampere DC breaker providing protection to the control box wiring and remote wiring from short circuits or overload. Also serves as an emergency stop switch. On commercial HDKAL/HDKAS model, this circuit breaker has an environmental cover.

**Fault Breaker CB12:** A manual reset breaker that shuts down the engine for low oil pressure and high coolant temperatures. On commercial HDKAL/HDKAS model, this circuit breaker has an environmental cover.

### Control Components

The following describes the basic engine control components and how they function.

**A11 Engine Monitor Circuit Board:** A circuit board that monitors the engine control system functions. This includes starting, stopping, and fault system operation. Terminals are included for making remote connections. See Figure 2-1.

Two relays soldered into the engine monitor board are not serviceable. They function as follows:

- Power relay A11-K12 connects battery B+ to the control meters and fuel solenoid during operation.
- Starter protection relay A11-K15 is AC operated. When the Start switch is pressed, B+ is connected to K11 start solenoid through the A11-K15 NC contacts until the generator output reaches about 90 volts AC. At this voltage A11-K15 activates and disconnects the starter circuit.

**K11 Start Solenoid:** Located to the left of the engine monitor circuit board (above K13 glow plug heater solenoid). It connects battery B+ to the start solenoid and glow plugs through K13 normally closed contacts during cranking.

**K13 Glow Plug Heater Relay:** Located to the left of the monitor circuit board on the bottom of the control box. It connects B+ to the engine glow plugs during preheat. It is energized by the Start/Stop/Preheat Switch S11.

**K14 Fuel Solenoid Relay:** It opens the fuel control valve, fuel pump when the start/stop switch is placed in the Start position.

**K15 Field Flash Relay:** Located in the DC control box. It connects B+ to the voltage regulator for field flashing during the start cycle. It is energized by start switch S11 during the start cycle and de-energized by A11-K15 after engine start.

**K16 Remote Start Relay:** Located in the DC control box. It connects B+ to K14 Fuel Solenoid and through the A11-K15 NC contacts to K11 Start Solenoid and K15 Field Flash Relay. It is energized by the remote Start/Stop/Preheat Switch S11.

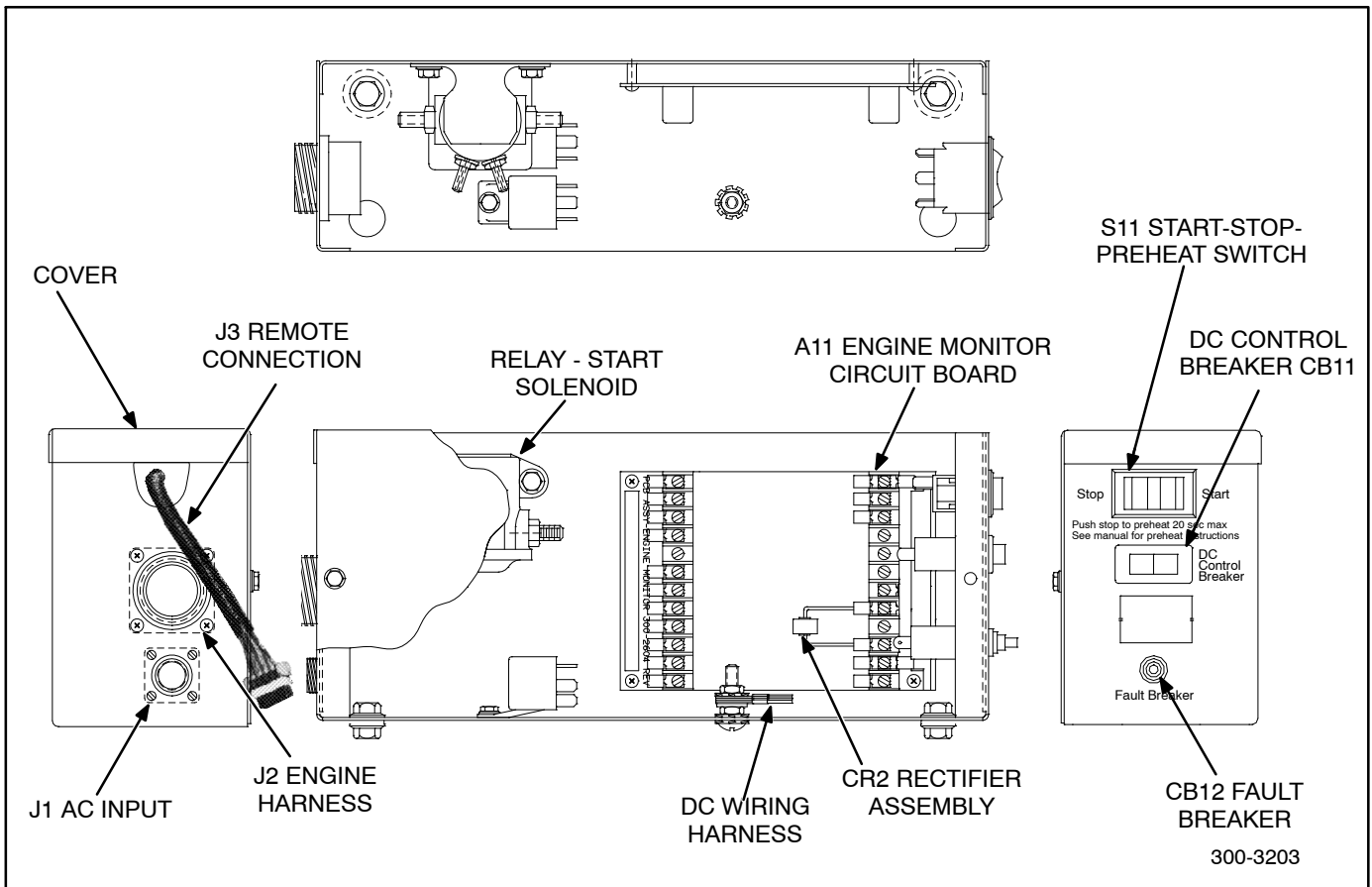

FIGURE 2-1. GENERATOR SET DC CONTROL BOX

## Engine Monitors

This section briefly describes the engine sensors (switches) and optional gauge senders. The sensors protect the engine from unfavorable operating conditions; the senders are used with the operational remote panel. These sealed units are not repairable. Do not use a substitute part if replacement is necessary, since they are close-tolerance parts made for a specific application.

The safety sensors (switches) close the fault circuit to ground if abnormal operating conditions exist, tripping the fault breaker CB12 to stop the engine. See Figure 2-2 and the schematic in Figure 2-3.

## Oil Pressure Monitors

Refer to Figure 2-2 for the location of the oil pressure monitors.

**Oil Pressure Sender E1:** The sender resistance changes with oil pressure and results in a reading on the (optional) oil pressure meter. The meter range is 0 to 100 psi (0 to 700 kPa).

**Low Oil Pressure Switch S1:** This switch closes if oil pressure drops to 9 psi (62 kPa), activating the fault breaker and stopping the engine.

**Control Power Latch S6:** This oil pressure switch closes at 5 psi (34 kPa) and provides a latch function for the control circuits. When closed, the switch supplies a ground path for relay K12 on the engine monitor board.

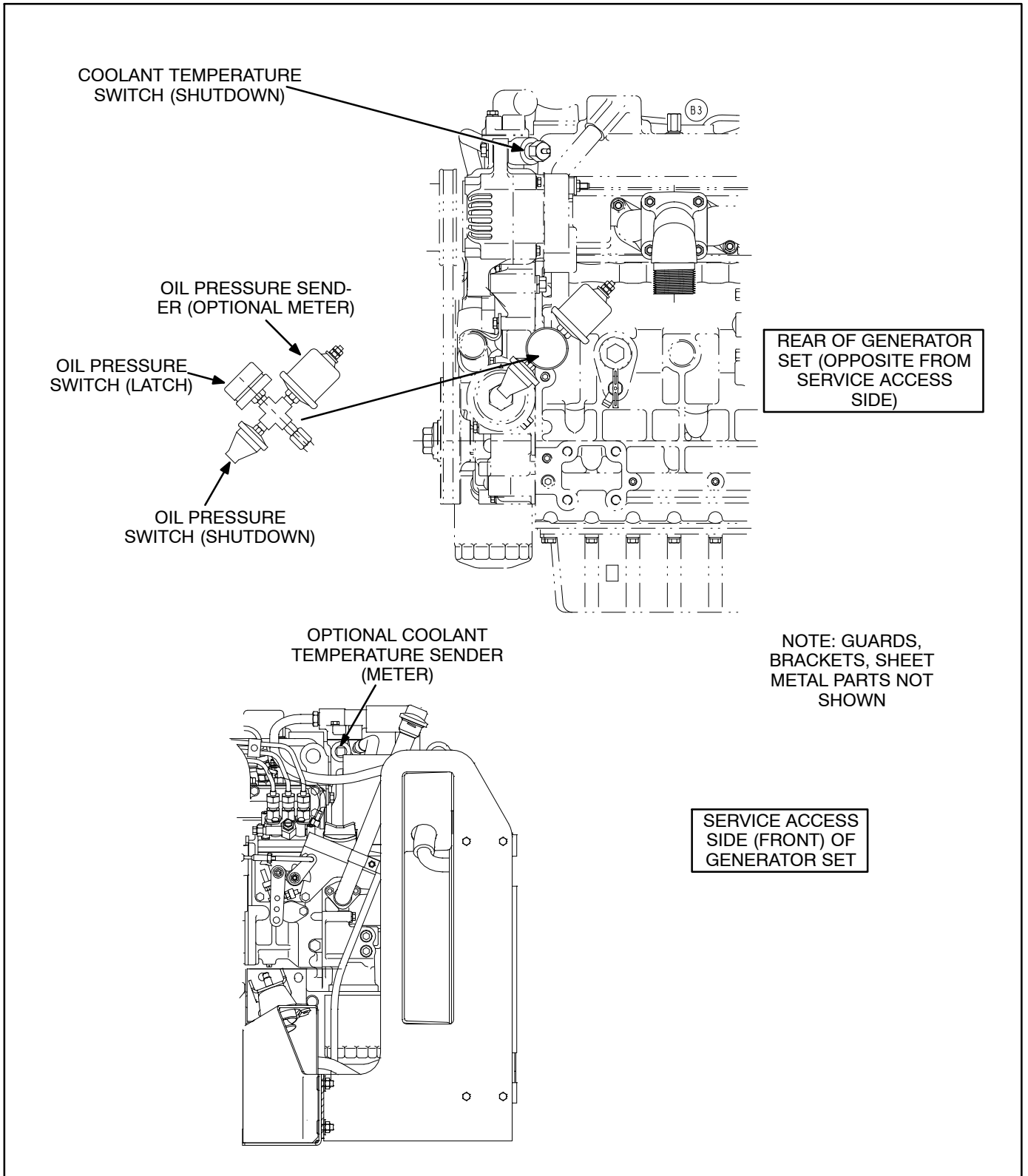

**FIGURE 2-2. FAULT SENSOR LOCATIONS**

## Engine Temperature Monitors

Refer to Figure 2-2 for the location of the engine temperature sensors.

**Coolant Temperature Sender E2:** The resistance of the sender unit changes with the engine coolant temperature and causes a reading on the coolant temperature meter (optional). The meter range is 100° to 250° F (40° to 121° C).

**High Coolant Temperature Switch S2:** This switch closes if the coolant temperature rises to 222° F (106° C), activating the fault breaker CB12 and stopping the engine.

## Control Operation

To understand control operation, refer to the following text and the schematic diagram (Figure 2-3).

**Starting Sequence:** When start/stop switch S11 is held in the *Stop* (preheat) position, battery B+ is connected to the coil of heater relay K13. The relay contacts close and connect B+ to heaters HR1 - HR3.

After the preheat time interval, the operator holds S11 in the *Start* position. This connects B+ to K14 fuel solenoid relay and through A11-K15 NC (normally closed) contacts to K15 field flashing relay and K11 start solenoid relay. These relays actuate K1 fuel solenoid, B1 solenoid/starter motor and heaters HR1 - HR3 (via K13 NC contacts).

A11-K12 power relay is actuated after a short delay, when the control power latch switch S6 closes. S6 is closed when oil pressure rises to 5 psi (34 kPa), assuring engine lubrication before the set reaches full operating speed. Normally open (NO) contacts on A11-K12 close, supplying B+ to the other components on the engine monitor board.

**Start-Disconnect Sequence:** As the generator gains speed and output voltage, A11-K15 starter protection relay energizes at about 90 VAC. A11-K15 NC contact opens and de-energizes start solenoid relay K11. K11 then disconnects B+ from the starter solenoid (to stop the cranking motor) and from the glow plug heaters. If the generator fails to develop voltage, the engine will attempt to start but will stop as soon as the Start switch is released.

The two A11-K15 NO (normally open) contacts close and function as follows:

- Closes circuit for S1 and S2 (low oil pressure and high coolant temperature switches respectively)
- Provides another ground path for A11-K12 coil (through K11 coil) similar to S6.

**Battery Charge Circuit:** Alternator G1, powered by a belt from the engine, supplies B+ voltage to recharge the generator set starting battery through circuit breaker CB13.

**Stopping Sequence:** Placing S11 in the *Stop* position puts B+ (through diode CR2) on the ground side of the A11-K12 power relay. This causes A11-K12 to de-energize and disconnect B+ from CB12 and K1 fuel solenoid. De-energizing K1 shuts off the fuel flow to stop the engine.

**Fault Shutdown:** Fault breaker CB12 opens to stop the engine any time a fault sensor closes the circuit to ground. The fault sensors as shown in Figure 2-2 are:

- S1 low oil pressure
- S2 high coolant temperature

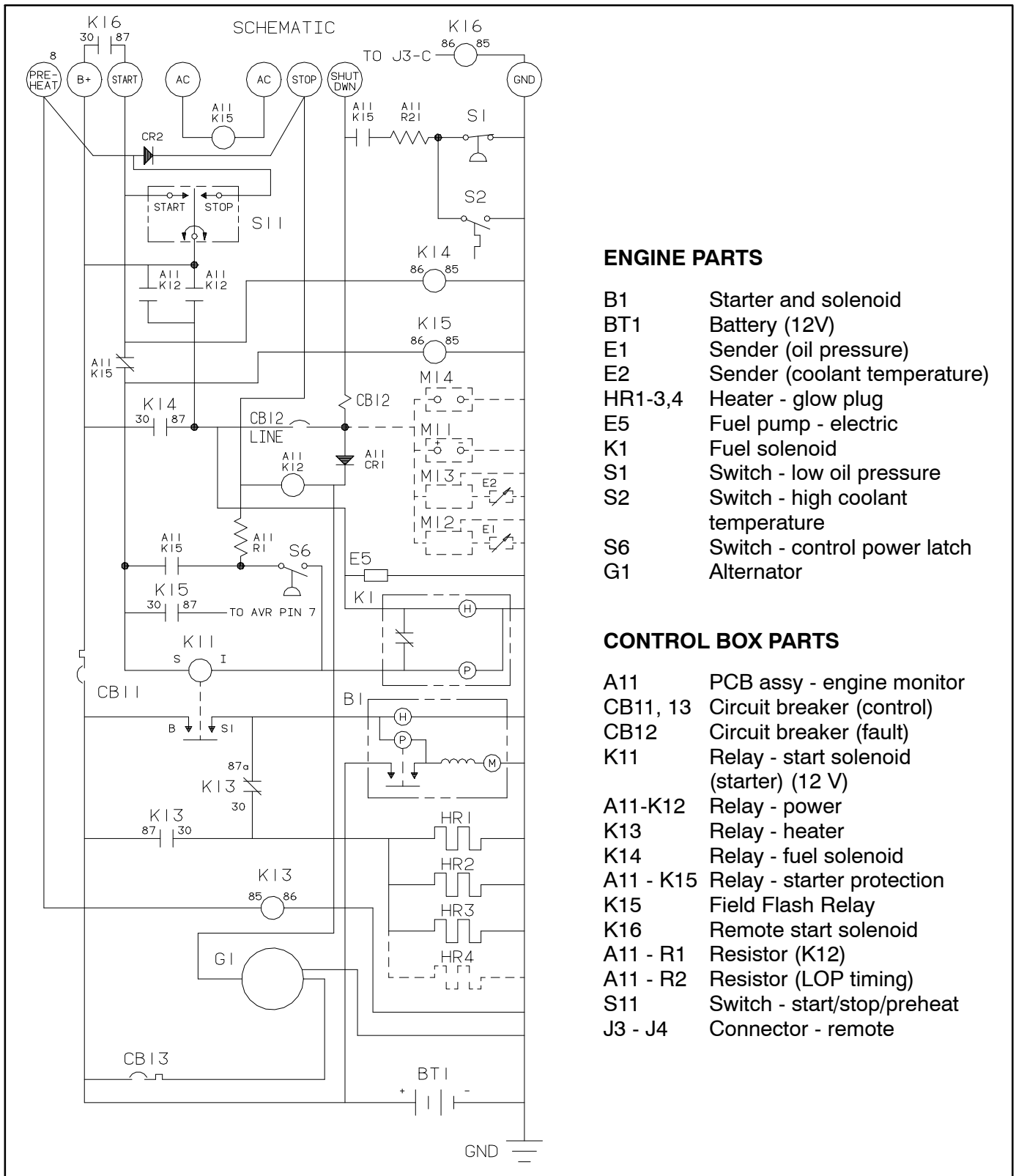

**FIGURE 2-3. DC CONTROL SCHEMATIC DIAGRAM**

**Remote Control Operation (Optional):** The generator set may be operated from a remote switch connected to the control receptacle J3. Installation instructions are furnished with the kit available from Cummins. See Figure 2-4.

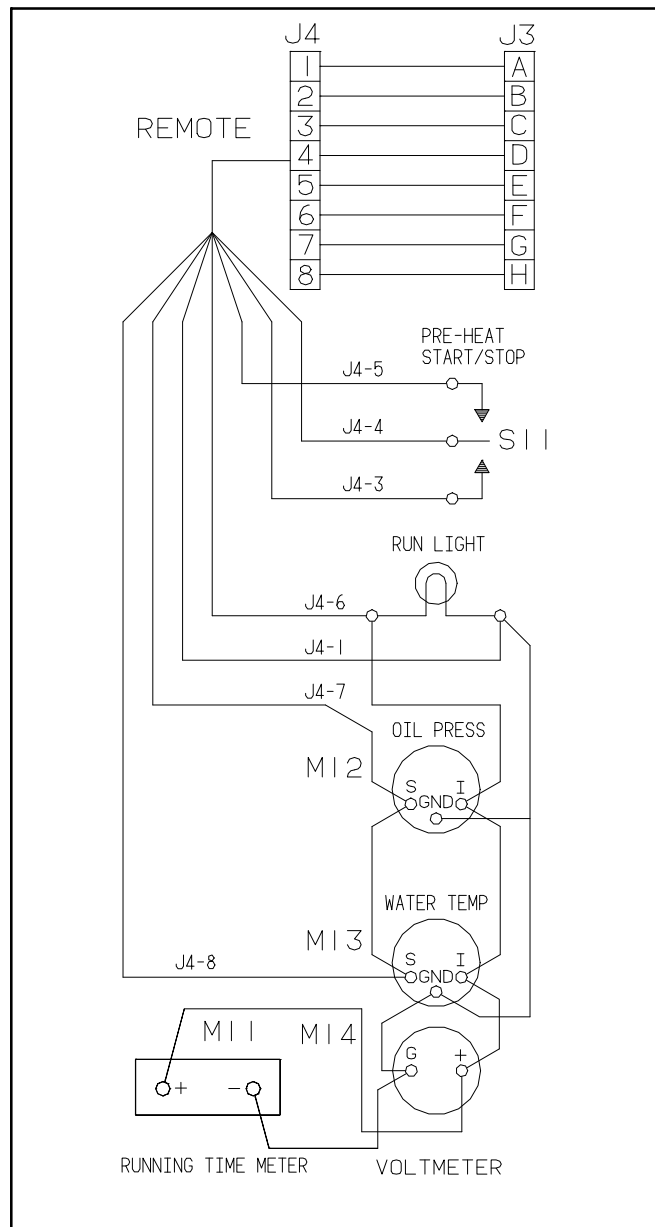

**FIGURE 2-4. REMOTE CONTROL WIRING DIAGRAM**

## CONTROL TROUBLESHOOTING

The information in this section is divided into three flow charts. Determine the problem and then refer to the appropriate flow chart (A, B, or C) for the troubleshooting procedures.

- A. Engine does not crank.
- B. Engine cranks but does not start.
- C. Engine starts but stops after running several seconds.

Before starting a troubleshooting procedure, make a few simple checks that may expose the problem and cut down on troubleshooting time.

- Check all modifications, repairs, and replacements performed since last satisfactory operation of set. A loose wire connection overlooked when installing a replacement part could cause problems. An incorrect connection, an opened switch or circuit breaker, or a loose plug-in are all potential problems that can be eliminated by a visual check.
- Unless absolutely sure that panel instruments are accurate, use portable test meters for troubleshooting.

To troubleshoot a problem, start at the upper-left corner of chart and answer all questions either YES or NO. Follow the chart until the problem is found, performing referenced adjustments or test procedures. Refer to Figures 2-1 through 2-4 for locating control components, leads, terminals and other check points.



## FLOW CHART A. ENGINE DOES NOT CRANK

**⚠WARNING** Many troubleshooting procedures present hazards that can result in severe personal injury or death. Only qualified service personnel with knowledge of fuels, electricity, and machinery hazards should perform service procedures. Review Safety Precautions.

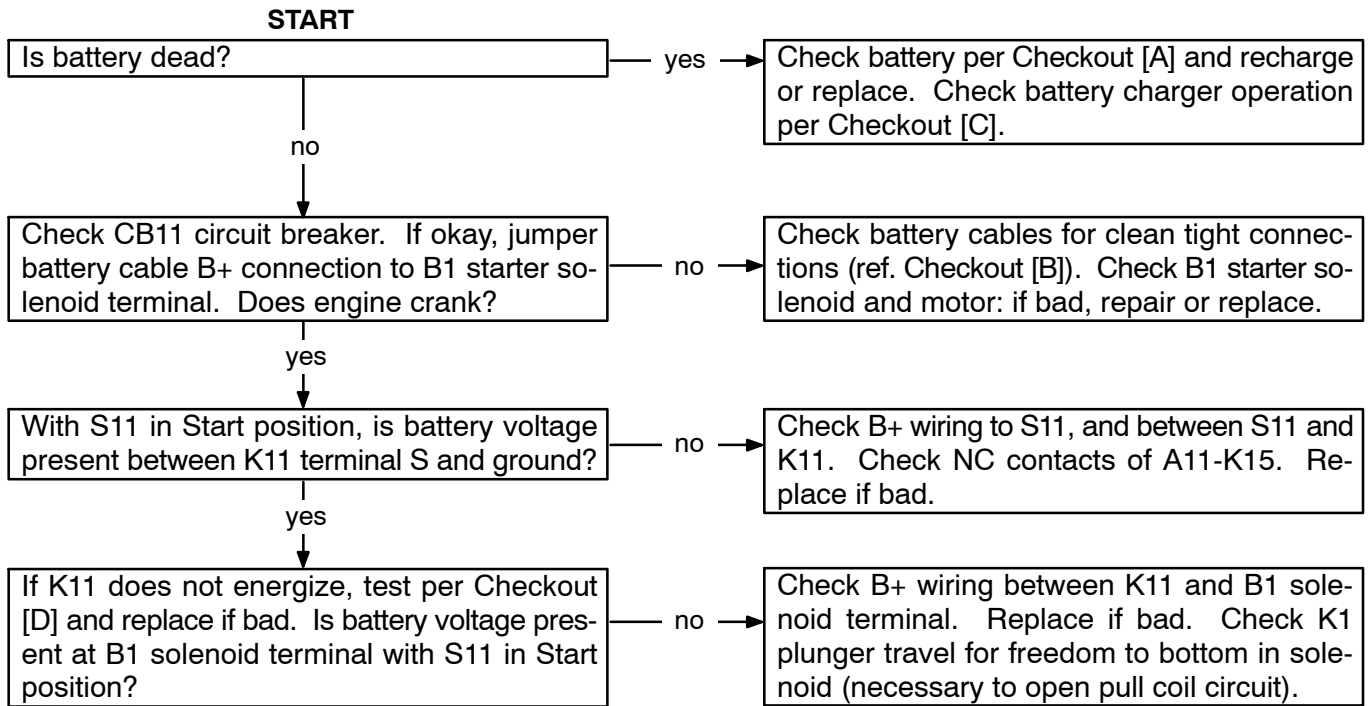

## FLOW CHART B. ENGINE CRANKS BUT DOES NOT START

**⚠WARNING** Many troubleshooting procedures present hazards that can result in severe personal injury or death. Only qualified service personnel with knowledge of fuels, electricity, and machinery hazards should perform service procedures. Review Safety Precautions.

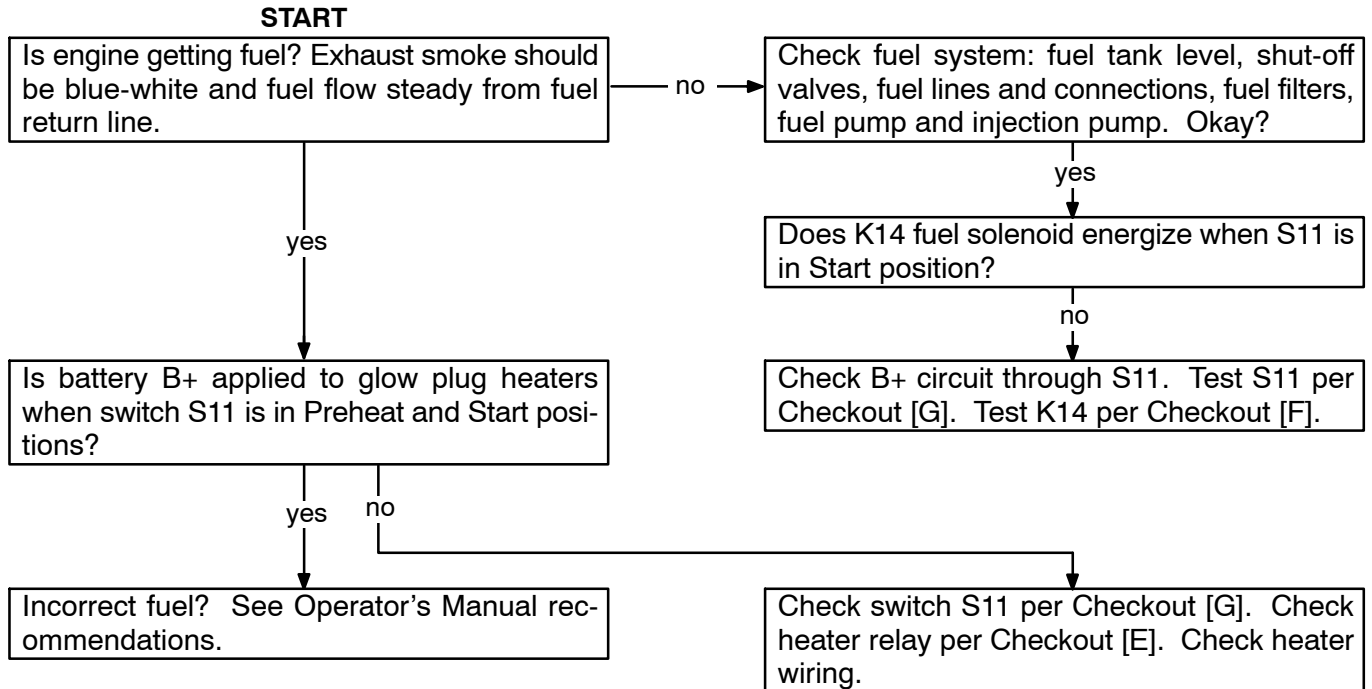

## FLOW CHART C. ENGINE STARTS BUT STOPS AFTER RUNNING SEVERAL SECONDS

**⚠WARNING** Many troubleshooting procedures present hazards that can result in severe personal injury or death. Only qualified service personnel with knowledge of fuels, electricity, and machinery hazards should perform service procedures. Review Safety Precautions.

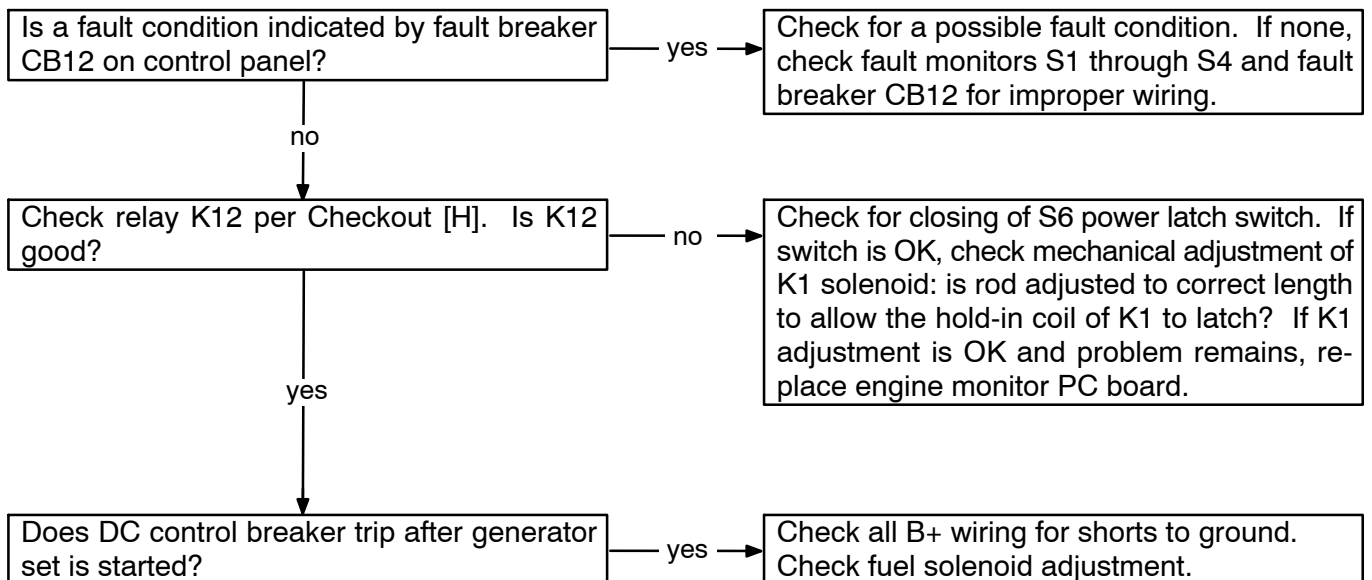

# 3. Engine Control Service

---

## GENERAL

The following checks are referred to in the Control Troubleshooting flow charts. They isolate circuit problems caused by faulty engine control components. Disconnect leads before testing components.

**⚠WARNING** *Many troubleshooting procedures present hazards that can result in severe personal injury or death. Only qualified service personnel with knowledge of fuels, electricity, and machinery hazards should perform service procedures. Review Safety Precautions.*

### [A]

#### BATTERY CHECK (BT1)

Check the battery charge condition with a hydrometer. Electrolyte specific gravity should be about 1.260 for a fully charged battery at 80°F (27°C). If not, add distilled water to keep electrolyte at proper level, then recharge the battery. If the battery will not recharge, replace it.

If the battery loses excess water, the charge rate may be too high. If the battery charge is not maintained, the charge rate may be too low. See procedure [C].

**⚠WARNING** *Ignition of explosive battery gases can cause severe personal injury. Do not permit any flame, spark, arcing equipment or switch, cigarette, or other ignition source near the battery.*

### [B]

#### BATTERY CABLE CHECK

With the starter motor running, check these voltage drops:

1. From the battery negative post (not the cable clamp) to the cylinder block

2. From the battery positive post to the battery terminal stud on the solenoid

Normally these should be less than 0.3 volts. If extra-long battery cables are used, slightly higher voltage drops may result. Thoroughly clean all connections in any part of the circuit showing excessive voltage drop.

### [C]

#### BATTERY CHARGING CHECK

With the engine running, check the DC voltmeter (control option). The 12-volt system should read 13.5 to 15 volts.

The power source is a belt-driven alternator. The charge rate/voltage is determined by a voltage regulator located inside the alternator.

Improper output may be caused by a loose drive belt, poor terminal connections, broken wires, bad regulator or alternator. Checkout procedures for the alternator are found in Section 5 of the engine service manual. The charge circuit is protected by circuit breaker CB13.

If the output voltage is high (over 15 volts), the regulator is probably shorted and the alternator should be replaced.

### [D]

#### START SOLENOID CHECK (K11)

1. Apply battery positive (B+) to the terminal marked S.
2. Connect a ground wire to the solenoid terminal marked I. The solenoid should activate.
3. If the contacts are good, battery voltage should be read between terminal 1 and ground. The voltage drop measured across the contacts should never exceed one volt in circuit application.

## [E]

### HEATER (GLOW PLUG) RELAY CHECK (K13)

1. Connect the relay coil voltage across the relay coil terminals. The relay should activate if coil is okay.
2. Connect a voltage source to one side of relay contacts.
3. Connect a voltmeter to other side of relay contact and voltage source. If voltage appears when relay energizes, the contact is good. The voltage reading appears in reverse order when checking normally closed (NC) contacts.

## [F]

### FUEL SOLENOID CHECK (K14)

If there is fuel to the injection pump, but no fuel at the injection nozzle, the fuel solenoid may be defective.

To check solenoid operation, watch for solenoid actuation when B+ is applied (start switch in start or run position). If there is no actuation when B+ is applied, the fuel solenoid must be replaced. When B+ is removed, the solenoid must de-activate.

## [G]

### START/STOP SWITCH CHECK (S11)

1. Remove battery B+ cable.
2. Place ohmmeter leads across switch.

3. Open and close switch while observing the ohmmeter. A normally open (NO) switch should indicate infinite resistance when open and continuity when closed. A normally closed (NC) switch should indicate continuity when closed and infinite resistance when open.
4. Replace switch if defective.

## [H]

### POWER RELAY CHECK (A11-K12)

Make certain that the generator set starting battery is good before beginning this check.

1. Unplug CB12-2A from the circuit breaker. Note the markings on the wire to select the correct one.
2. Locate S6 (oil pressure switch) on the generator set (see Figure 2-2). Find the grounded side of S6, using a continuity tester.
3. Use a jumper to ground the non-grounded side of S6.
4. Use a second jumper from the B+ terminal on the control board to apply B+ to the SW B+ (switched B+) terminal. Fuel pump E5 should start and run.
5. Remove the B+ jumper. If the fuel pump continues to run, K12 is good. If the fuel pump stops, K12 has failed and the A11 control board should be replaced.
6. Push the generator set STOP button.
7. Remove the jumpers and reconnect CB12-2A.

# 4. Generator Set/Voltage Regulator

## GENERAL DESCRIPTION

The YK generator set (Figure 4-1) is a four-pole, revolving field, brush-type design with drip-proof construction.

The generator set rotor is directly coupled to the engine flywheel with a flexible drive disc. Engine speed determines generator set output voltage and frequency. A centrifugal blower on the drive disc cir-

culates generator set cooling air which is drawn in through the end bell and discharged through an outlet in the blower end.

A ball bearing in the end bell supports the outer end of the rotor shaft. The end bell is attached with four studs that thread into the generator set adapter casting. The generator set brushes are mounted in the end bell (see Figure 4-2).

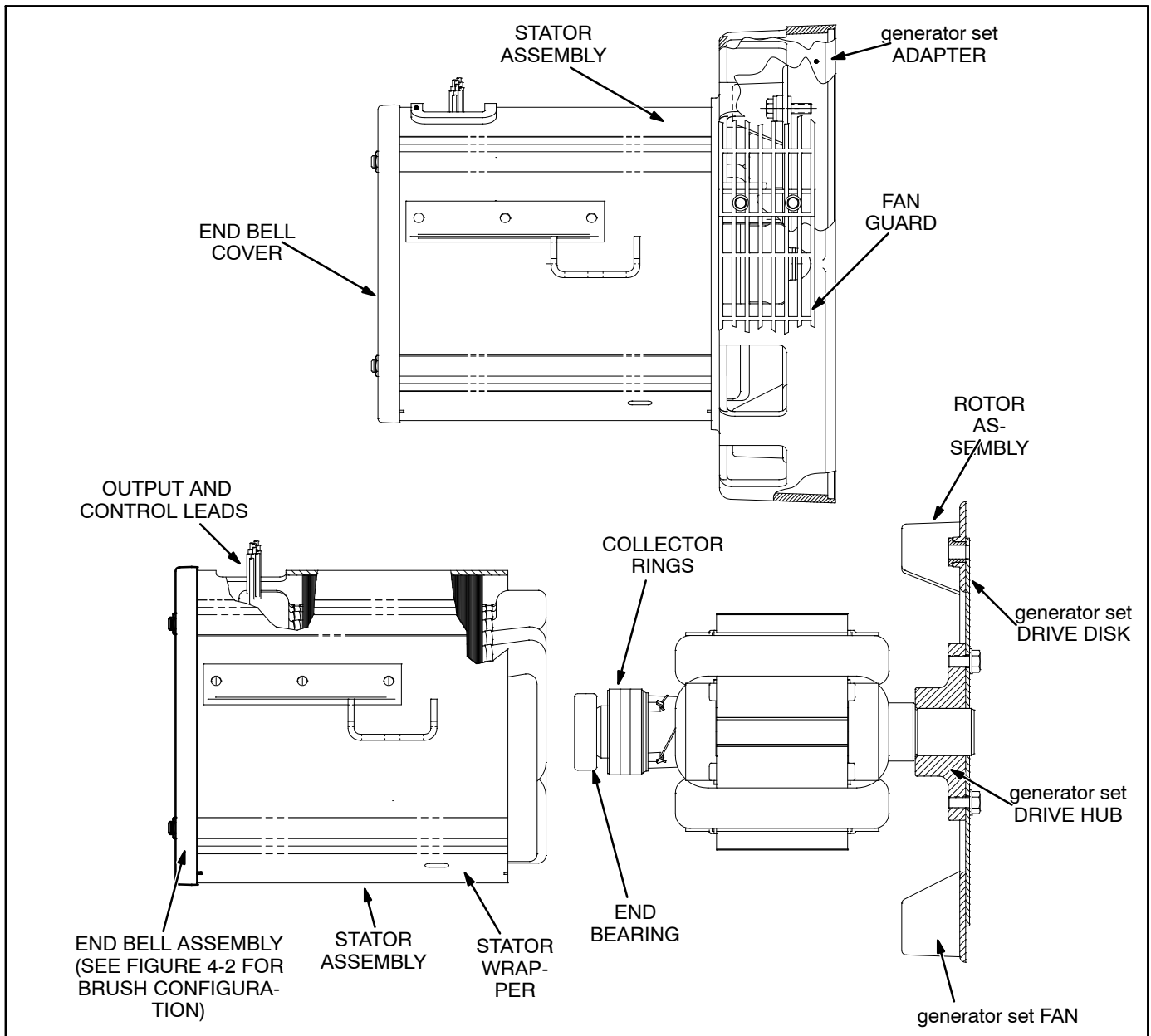
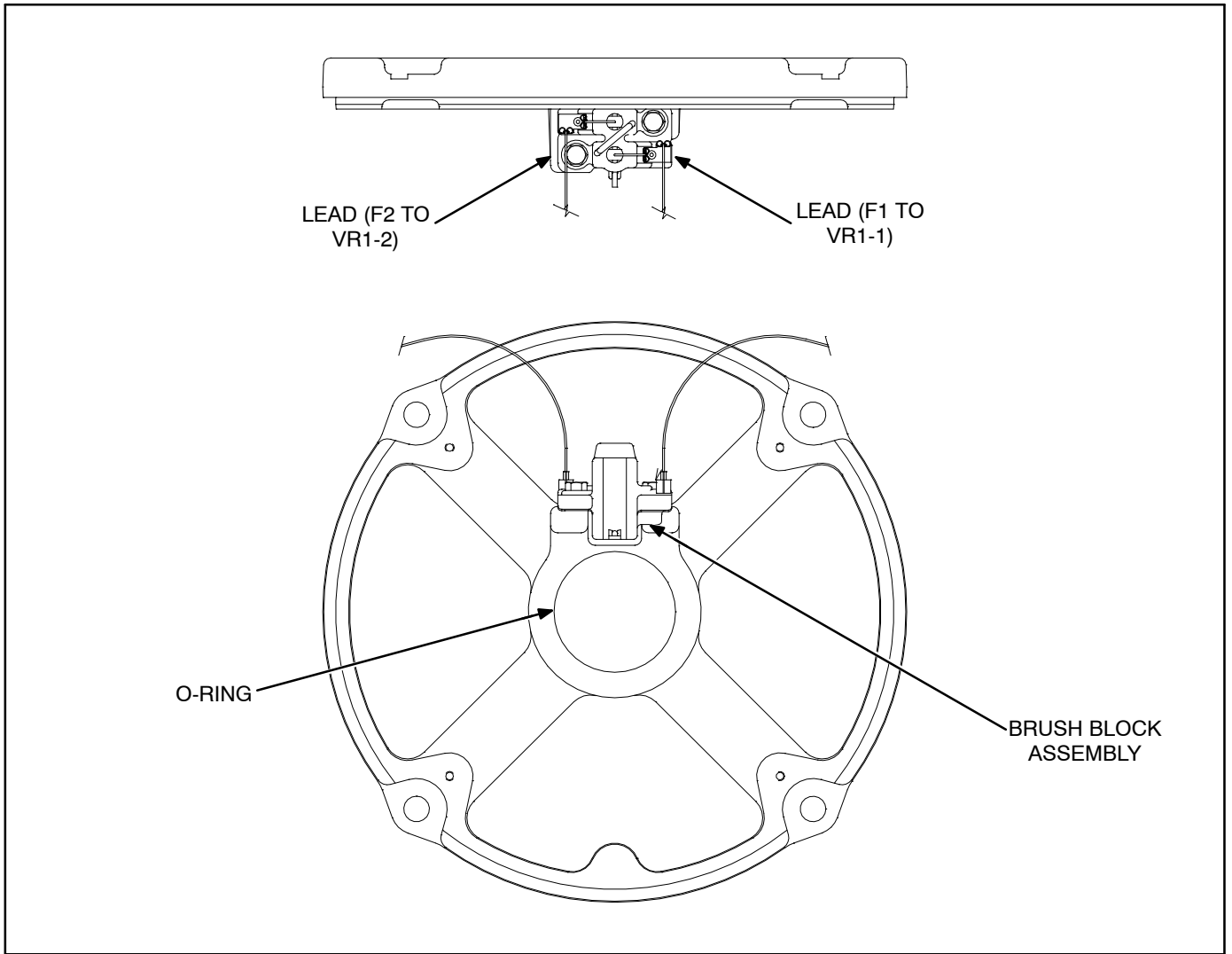

FIGURE 4-1. YK SERIES generator set



**FIGURE 4-2. GENERATOR SET END BELL WITH BRUSHES**







## GENERATOR SET OPERATION

Refer to Figures 4-3 generator set schematic, while working through the following description.

1. Voltage regulator VR1 (three-phase VR21) supplies DC to the field winding (F1 - F2 leads) through brushes and slip rings, thereby establishing a revolving 4-pole magnetic field. The battery is connected during startup to initiate field excitation. Voltage regulator VR1 supplies field current during operation. Rated output voltage is maintained as the generator set load varies, by varying field current to maintain field strength proportional to the load.
2. The revolving magnetic field induces AC in the stator windings (T1 - T2 and T3 - T4) which are connected to the load.
3. Under light load, the stator windings can supply sufficient current for the field to maintain rated output voltage.
4. As the load increases, load currents increase, resulting in a proportional increase of current, which in turn supplies the field. Rated output

voltage is thereby maintained as the load varies.

## ELECTRONIC VOLTAGE REGULATOR

The voltage regulator controls the output of the generator set so that a constant voltage is maintained under varying load conditions.

Only the basic functions of the regulator are described (Figure 4-5). Voltage from quadrature windings Q1/Q2 supply power to the voltage regulator itself. The voltage regulator in turn supplies a field voltage (F1/F2) that is directly proportionate to the output voltage (L1/L0) it senses. Any changes in the generator set output voltage produce a corresponding change in the field voltage provided by the regulator.

On the HDKAL/HDKAQ/HDKAR/HDKAS, the voltage regulator assembly includes a potentiometer which enables a slight degree of output voltage adjustment. The voltage regulator assembly contains no user-serviceable parts. If the assembly fails, it must be replaced.

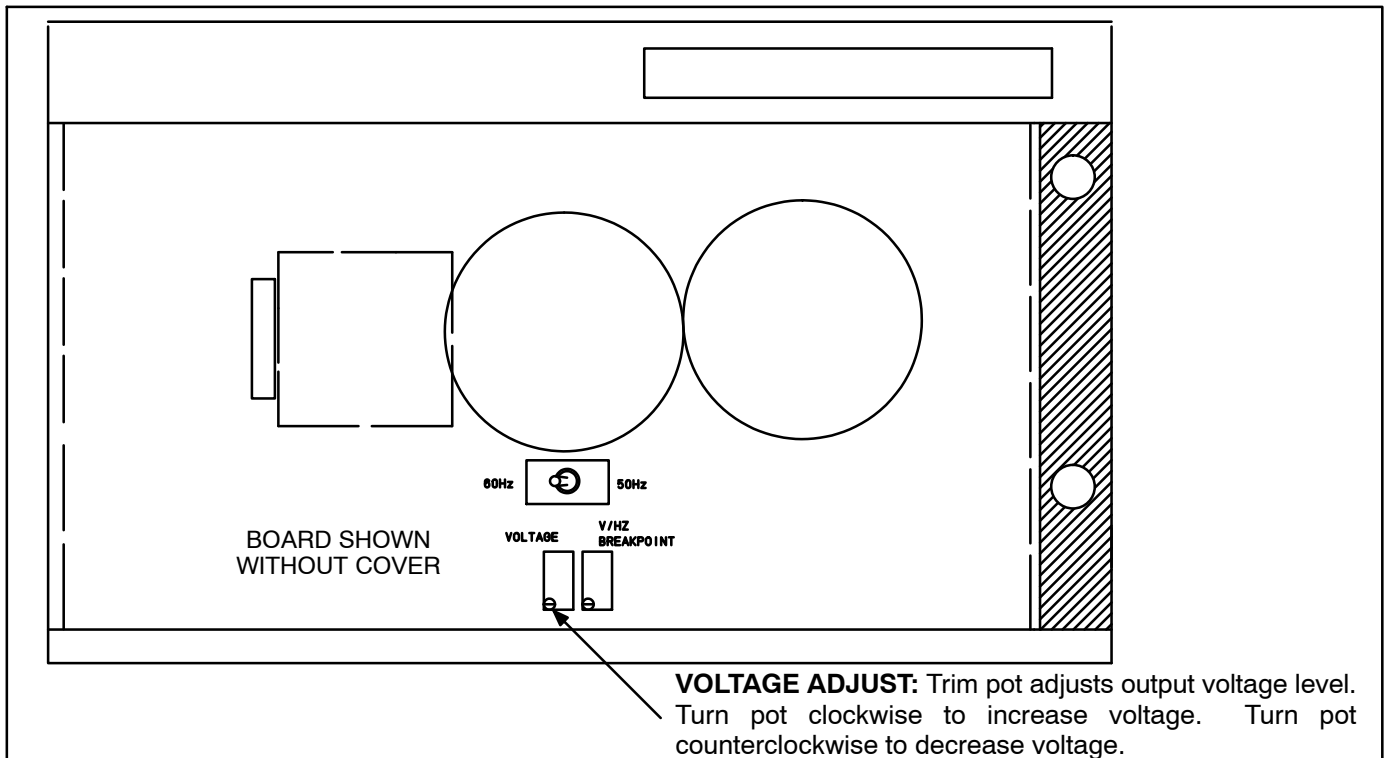

FIGURE 4-5. ADJUSTMENTS ON GENERATOR SET VOLTAGE REGULATOR BOARD

## GENERATOR SET SERVICE

Always disconnect the battery cables (negative [-] first) from the battery to prevent accidental starting of the set while servicing the generator set.

**⚠ WARNING** *Accidental starting of the set while working on it can cause severe injury. To prevent accidental starting, disconnect the battery cables (negative [-] first) from the battery.*

*The negative (-) cable is always disconnected first, and connected last, to prevent arcing if a tool accidentally touches the frame or other grounded metal parts of the set while disconnecting or connecting the positive (+) cable. Arcing can ignite the explosive hydrogen gas given off by the battery, and cause severe injury.*

### Brush Inspection/Replacement

The generator set should be inspected for brush wear and cleaning every six months.

**⚠ WARNING** *Accidental starting of the generator set can cause severe personal injury or death. Stop the generator set and disable by disconnecting the starting battery cables (negative [-] cable first) before inspecting the generator set.*

1. Remove the access cover for the brush assembly.
2. Check the brushes for wear with a piece of wire marked off 1 inch (25 mm) from one end (Figure 4-6). Replace the brush and the spring if the wire goes into the brush holder 1 inch or more.
3. To replace brushes, remove the brush holder by disconnecting the two leads to the holder and removing the two mounting screws.

4. Install the new brushes and springs in the holder and keep them in place during assembly by inserting a piece of wire through the holder, as shown in Figure 4-7.
5. Install the brush holder. After tightening the mounting screws, pull out the brush retaining wire.
6. Connect the F1 lead to the inner brush terminal (nearest the rotor windings). Connect the F2 lead to the outer brush terminal (nearest the end bell).

### Slip Ring Inspection/Replacement

Inspect the slip rings for grooves, pits or other damage. If dust has accumulated on any generator set components, they can be cleaned with filtered low-pressure air.

1. Examine the slip rings while servicing the brushes.
2. If the rings need cleaning or service, remove the rotor from the generator set and dress the rings on a lathe.

**⚠ CAUTION** *Dressing the slip rings on a lathe improperly may damage the generator set rotor. Make certain that only an experienced technician performs this job.*

### generator set Bearing

Inspect the bearing for evidence of outer case rotation every 1000 hours of use. The bearing should be replaced every five years, because the bearing grease gradually deteriorates due to oxidation.

Replace the O-ring if it shows evidence of wear or deterioration. Renew grease if necessary (moly only).

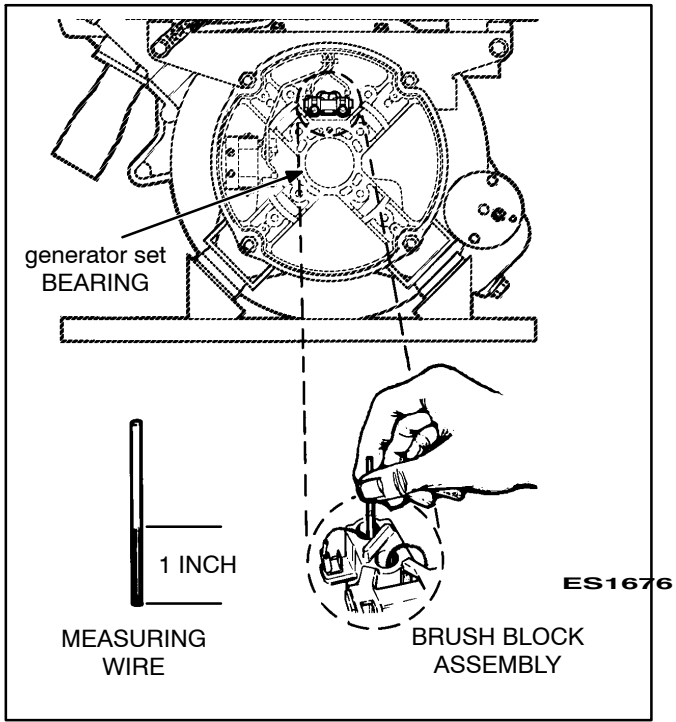

**FIGURE 4-6. CHECKING generator set BEARING AND BRUSH BLOCK**

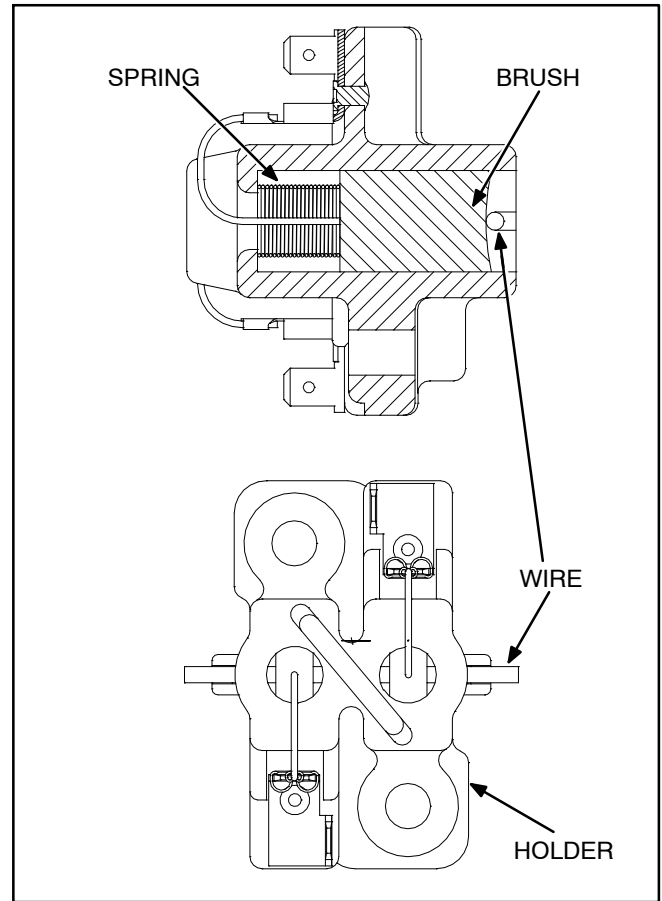

**FIGURE 4-7. BRUSH REPLACEMENT**

## GENERATOR SET DISASSEMBLY / ASSEMBLY

The following sections describe the disassembly and reassembly procedures for the generator set. Figure 4-8 illustrates generator set disassembly.

**⚠WARNING** *generator set components are heavy and can cause severe personal injury if dropped during service. Be careful, use appropriate lifting techniques, keep hands and feet clear during service, and use the recommended service procedures.*

**Note that the control box and air cleaner assembly need not be removed from the set to disassemble the generator set. These components may remain attached to the stator housing, and will be removed with it.**

### Disassembly

1. Remove the generator set from the vehicle and place it on a sturdy work bench. Refer to Section 1 of this manual for removal guidelines.

**⚠WARNING** *Accidental starting of the set can cause severe personal injury or death. Disconnect the battery cables, negative (-) lead first, when repairs are made to the engine, controls or generator set.*

2. Remove the cover from the AC control box and disconnect all stator leads (Q1-Q50/60, T1-T2-T3-T4, F1-F2, S1-S2). Disconnect leads at the load circuit breaker(s). If the lead markings do not clearly identify reconnection, mark the leads with tape.
4. Loosen and remove the two bolts that extend through the rear generator set mounts (under the stator housing).
5. Lift the rear of the set and place a wooden block under the generator set adapter to hold the sta-

tor and housing in place. Make certain that the engine-to-generator set adapter (bolted to the engine) is propped up high enough for the generator set adapter assembly (bolted to the generator set) to clear the rear generator set mounts when it is pulled off the set. A block approximately 3.5 inches wide (standard 2 x 4 lumber width) will hold the adapter high enough. Remove the two rubber vibration isolators whose bolts were removed in the last step.

6. Remove the end bell cover and disconnect F1 (outer) and F2 (inner) lead wires from the brush holder terminals.
7. Pull each brush away from the commutator rings and insert a piece of stiff wire into the small hole in the brush holder. See Figure 4-7.

**Note that the brushes may be secured (as described in the last two steps) at any convenient point during this procedure.**

8. Remove four nuts and lock washers from the generator set stud bolts. Remove the end bell cover and pry the end bell free of the rotor bearing. Be careful not to damage the brush holder.
9. Pull the stator/wrapper assembly with the control boxes off the rotor and away from the engine. Set it aside.
10. Remove the four bolts that hold the generator set adapter and fan guard to the engine-to-generator set adapter. Pull the adapter/guard assembly off the adapter and set it aside.
11. Loosen the six bolts that hold the rotor drive disk to the engine flywheel. Loosen these bolts in an alternating pattern, so that the drive disk does not bend from the weight of the rotor.
12. Pull the rotor, fan and drive disk assembly off the flywheel and set them aside.

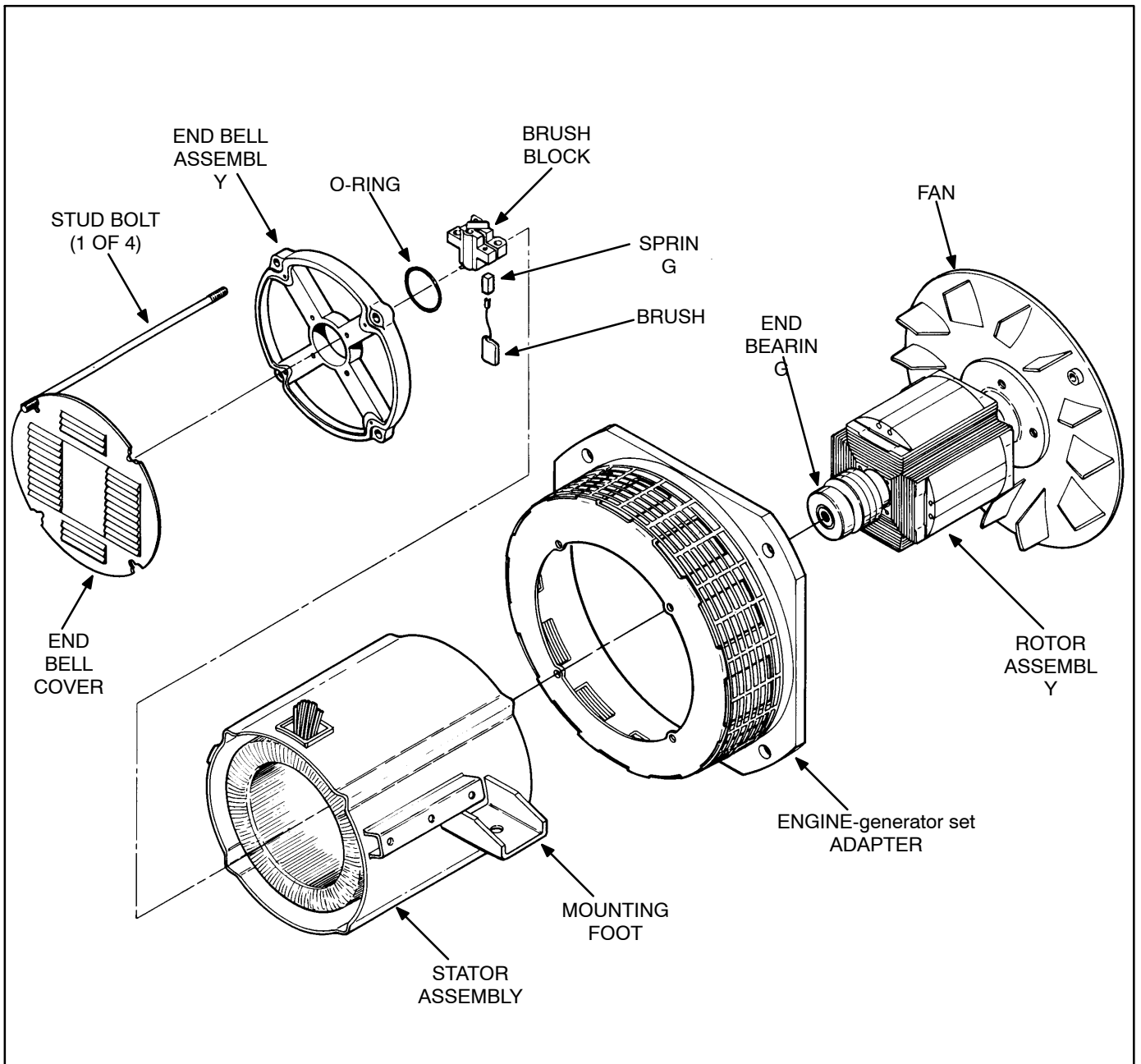

**FIGURE 4-8. GENERATOR SET DISASSEMBLY/REASSEMBLY**

## Rotor Disassembly

1. Place the rotor assembly on a wood block in the horizontal position. **The drive disk and fan should not be resting on anything, or distortion may occur.**
2. Remove the six bolts that hold the drive disk and fan to the rotor hub. Remove the drive disk and fan.
3. Use a gear puller to remove the end bearing from the rotor shaft .

**⚠ CAUTION** *The end bearing will be damaged if pulled on the outer race. If the bearing must be removed, replace it; this bearing should not be reused.*

## Rotor Bearing Replacement

1. Clean the bearing and shaft mating surfaces.

2. Apply Loctite #680 adhesive to the shaft mating surface.
3. Apply Loctite #747 activator to the bearing mating surface.
4. Install the bearing and allow ten minutes curing time before handling the assembly.

## Rotor Reassembly

After necessary service checks and repairs are made, the rotor and generator set are reassembled using the reverse procedure of disassembly except for the rotor as noted below. Regrease the O-ring using moly grease only. Apply required torque value shown in Figure 4-9.

**⚠ CAUTION** *The drive disk will be damaged if the bolts are tightened and it is not properly centered. Center the disk accurately before beginning to tighten the drive disk.*

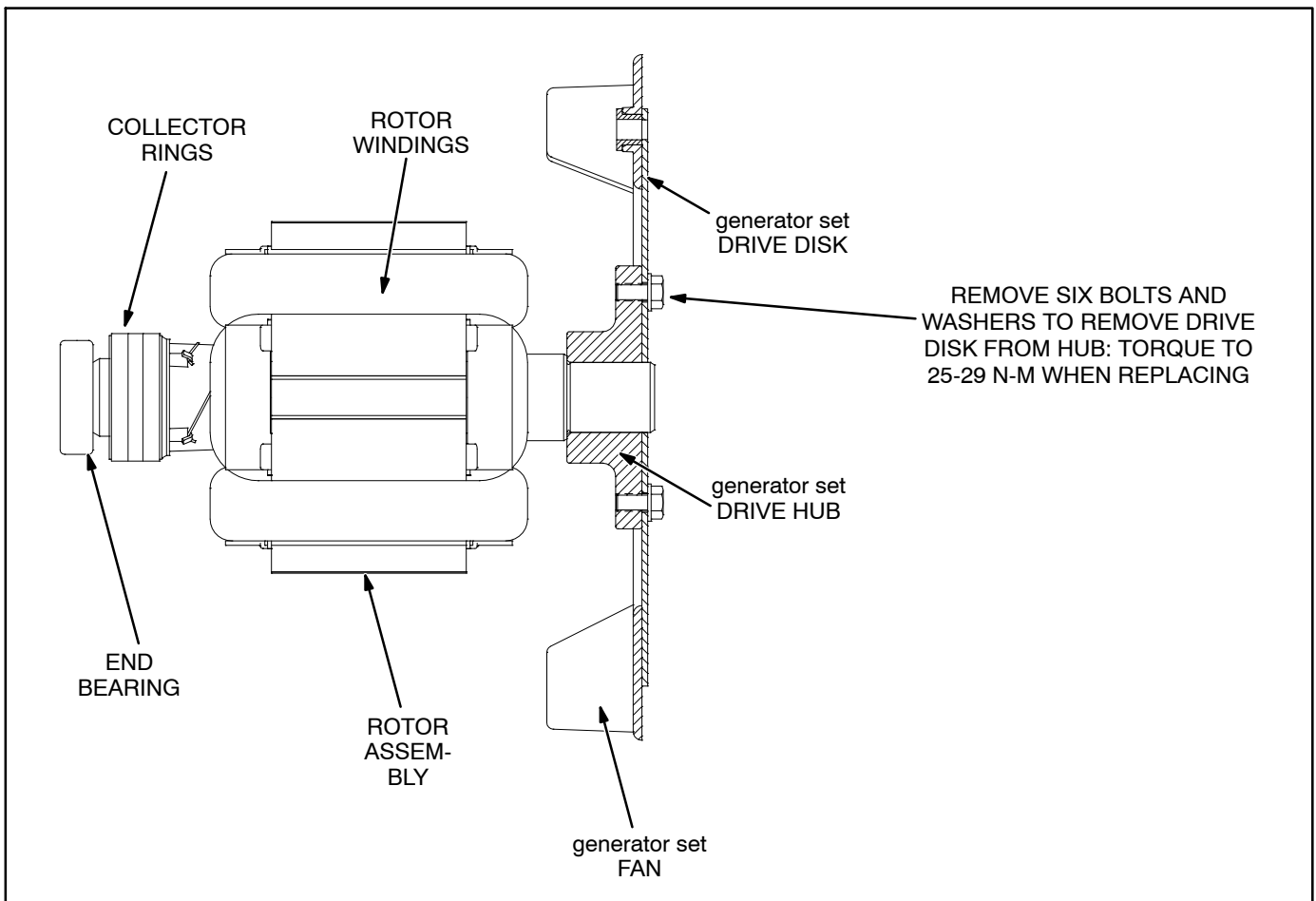

FIGURE 4-9. ROTOR ASSEMBLY COMPONENTS

# 5. Generator set/Regulator Troubleshooting

## GENERAL

This section contains troubleshooting information for the HDKAL/HDKAQ/HDKAR/HDKAS generator set and voltage regulator. Make the following visual checks before starting:

- Check any modification or repair that was done since the last satisfactory operation of the set. Verify that it was done properly.
- Check to see that generator set leads are connected correctly. Also check the voltage regulator and control component connectors. A loose, contaminated, or misplaced wire connection can be detected by close inspection.
- Check for an open circuit breaker. If the breaker is open, check for an overloaded circuit and correct load problems before resetting the breaker.

## TROUBLESHOOTING PROCEDURES

Determine the type of problem, then refer to the corresponding flow chart (A, B, C, or D) for troubleshooting procedures.

- A. NO AC OUTPUT VOLTAGE AT RATED ENGINE RPM
- B. UNSTABLE OUTPUT VOLTAGE, ENGINE SPEED STABLE
- C. OUTPUT VOLTAGE TOO HIGH OR TOO LOW
- D. UNBALANCED OUTPUT VOLTAGE

To troubleshoot a problem, start at the upper left corner of the chart that corresponds to the problem, and answer all questions either YES or NO. Follow the chart until the problem is found. Perform the referenced test or adjustment procedures in the generator set/Regulator Tests section.

Components referenced in the flow charts, tests and adjustment procedures are found in the sche-

matics and wiring diagrams in Section 9 of this manual.

## FAULT CODE BLINKING

At fault shutdown, the status indicator light will repeatedly blink sets of 1, 2, 3 or 4 blinks.

- **One blink** indicates shutdown due to high engine coolant temperature.
- **Two blinks** indicate shutdown due to a loss of engine oil pressure.
- **Three blinks** indicate a service fault. Press **Stop** once to cause the two-digit, second-level shutdown code to blink. (Pressing **Stop** again will stop the blinking.) The two-digit code consists of 1, 2, 3, 4 or 5 blinks, a brief pause, and then 1 to 9 blinks. The first set of blinks represents the tens digit and the second set of blinks the units digit of the shutdown code number. For example, **shutdown code No. 36** appears as:

blink-blink-blink—*pause*—blink-blink-blink-blink-blink-blink—  
*long pause*—repeat

- **Four blinks** indicate that cranking time exceeded 35 seconds.
- *Fault Code Nos. 1, 2, 3, and 4 are first level faults. Pay close attention to the pause sequence to avoid interpreting first level faults as second-level Fault Codes Nos. 11, 22, 33, or 44.*
- *To avoid the possibility of anyone misinterpreting Code Nos. 3 and 4 as Code Nos. 33 and 44, the latter have not been assigned faults.*

## RESTORING FAULT CODE BLINKING

The fault code stops blinking after five minutes. Press **Stop** three times within three seconds to restore fault code blinking.

**Note: The last fault logged will blink even though the condition that caused the shutdown may have been corrected.**

## FLOW CHART A. NO AC OUTPUT VOLTAGE AT RATED ENGINE RPM

**⚠WARNING** Many troubleshooting procedures present hazards that can result in severe personal injury or death. Only qualified service personnel with knowledge of fuels, electricity, and machinery hazards should perform service procedures. Review Safety Precautions.

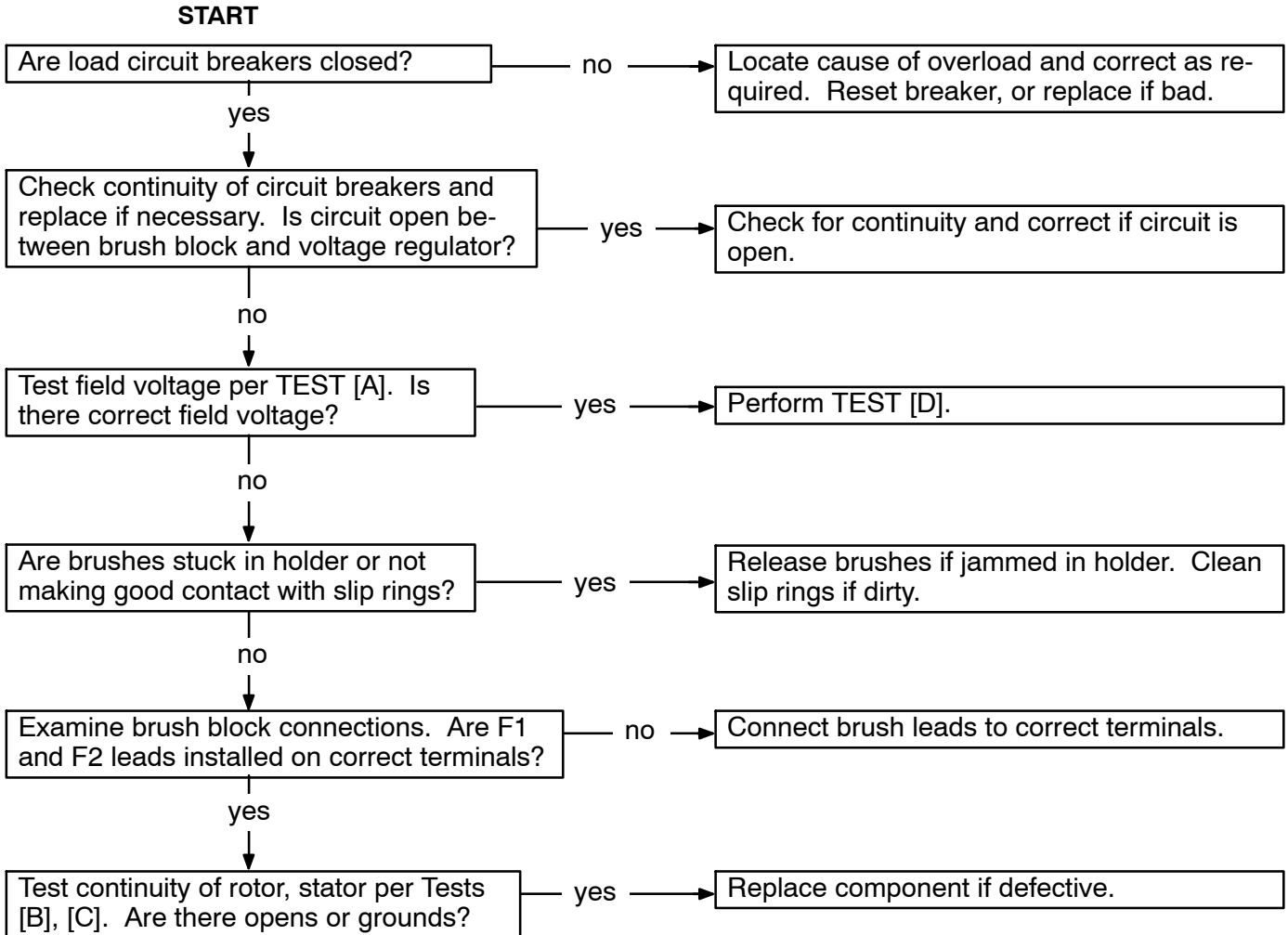



## FLOW CHART B. UNSTABLE VOLTAGE, ENGINE SPEED STABLE

**⚠ WARNING** *Many troubleshooting procedures present hazards that can result in severe personal injury or death. Only qualified service personnel with knowledge of fuels, electricity, and machinery hazards should perform service procedures. Review Safety Precautions.*

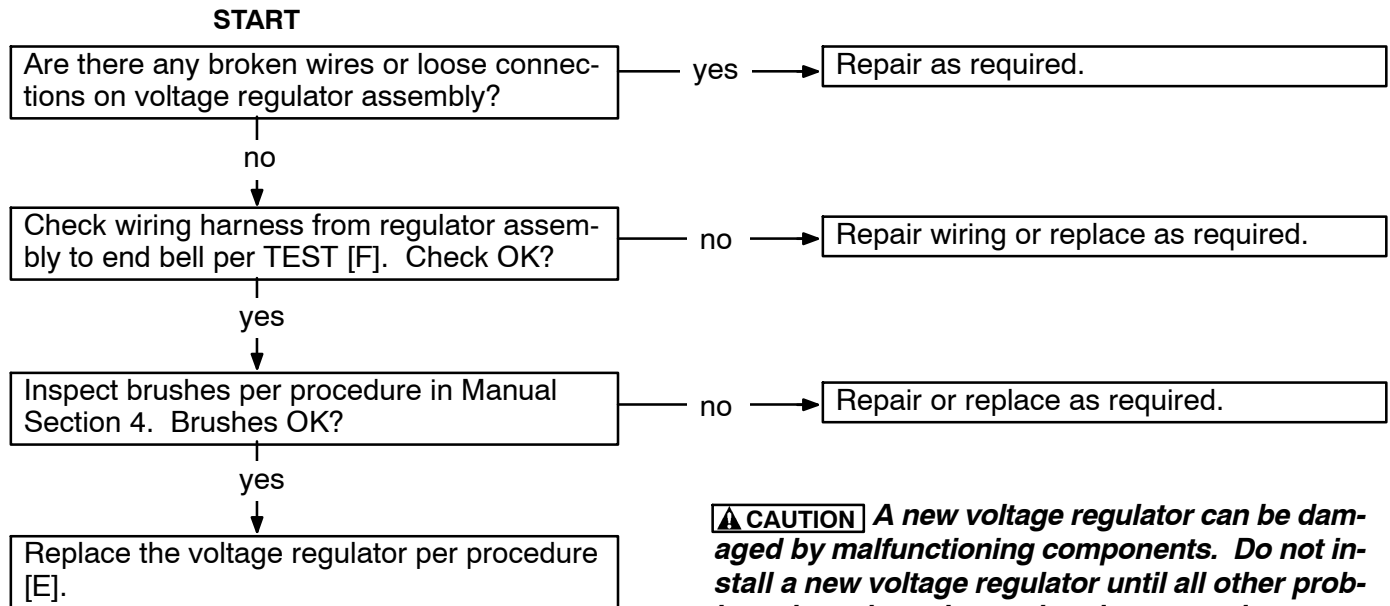

### FLOW CHART C. OUTPUT VOLTAGE TOO HIGH OR TOO LOW

**⚠ WARNING** Many troubleshooting procedures present hazards that can result in severe personal injury or death. Only qualified service personnel with knowledge of fuels, electricity, and machinery hazards should perform service procedures. Review Safety Precautions.

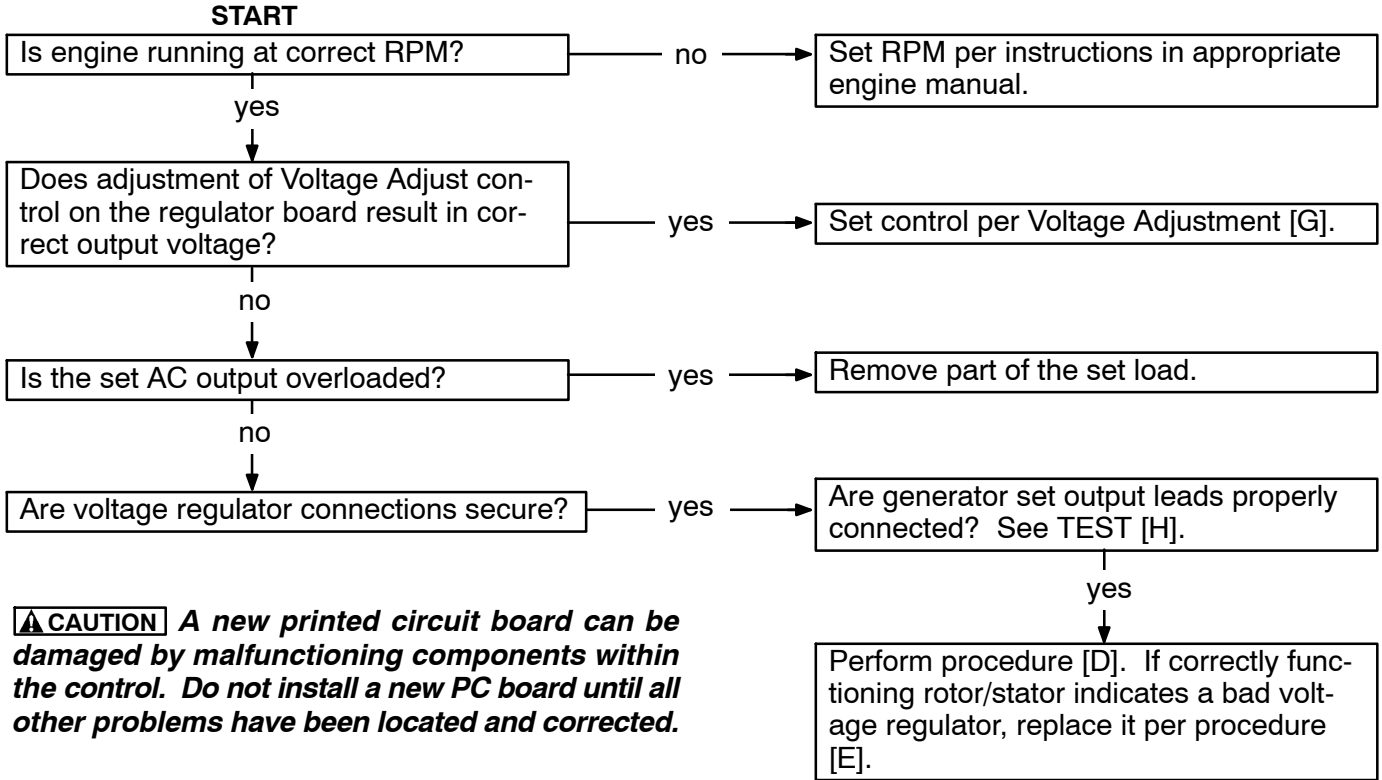

### FLOW CHART D. UNBALANCED generator set OUTPUT VOLTAGE

**⚠ WARNING** Many troubleshooting procedures present hazards that can result in severe personal injury or death. Only qualified service personnel with knowledge of fuels, electricity, and machinery hazards should perform service procedures. Review Safety Precautions.

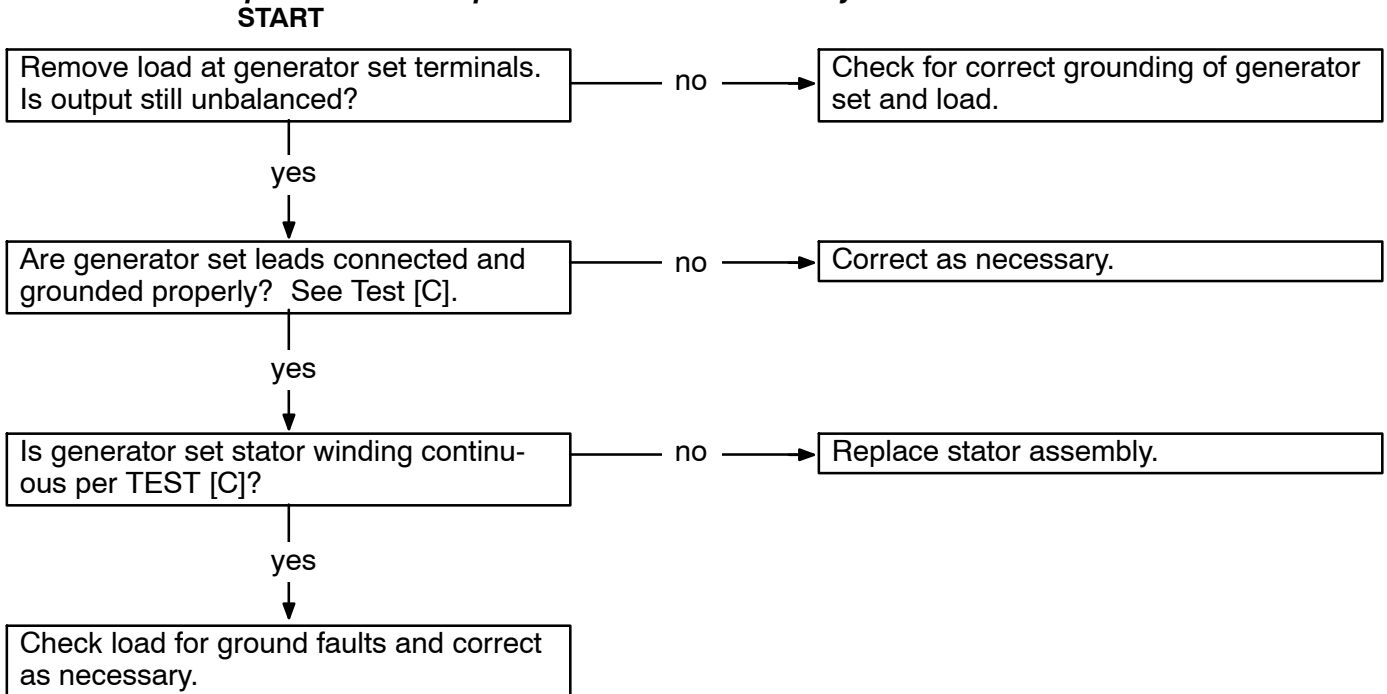

# 6. Generator Set/Regulator Tests

## GENERAL

The following tests and adjustments can be performed without disassembly of the generator set. These procedures should be used for testing the generator set components and the regulator in conjunction with the Troubleshooting Flow Charts in the generator set/Regulator Troubleshooting section.

**⚠ WARNING** Many troubleshooting procedures present hazards that can result in severe personal injury or death. Only qualified service personnel with knowledge of fuels, electricity, and machinery hazards should perform service procedures. Review safety precautions on inside cover page.

### [A] TESTING FIELD VOLTAGE

Field voltage can be tested at the brush holder terminals with a DC voltmeter. Field voltage should fall between 18 and 60 volts. Test at no load and at full load. See Figure 6-1.

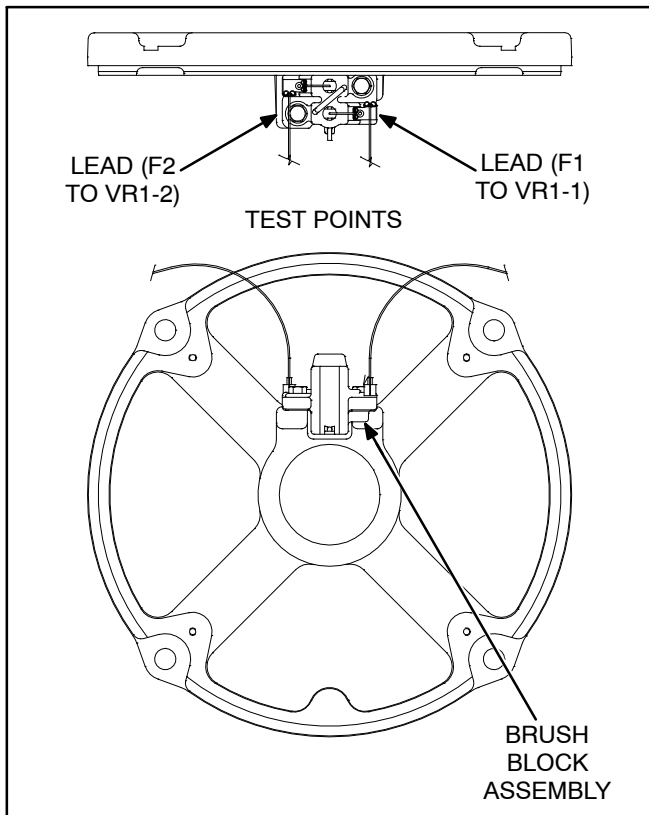

FIGURE 6-1. FIELD VOLTAGE TEST POINTS

### [B] TESTING generator set ROTOR

The generator set circuits can be tested without having to disassemble the generator set. It is recommended that an ohmmeter be used to check for open circuits and an insulation resistance meter for grounded circuits. An ohmmeter can be used to check for grounded circuits, but it may not be able to detect marginal insulation breakdown.

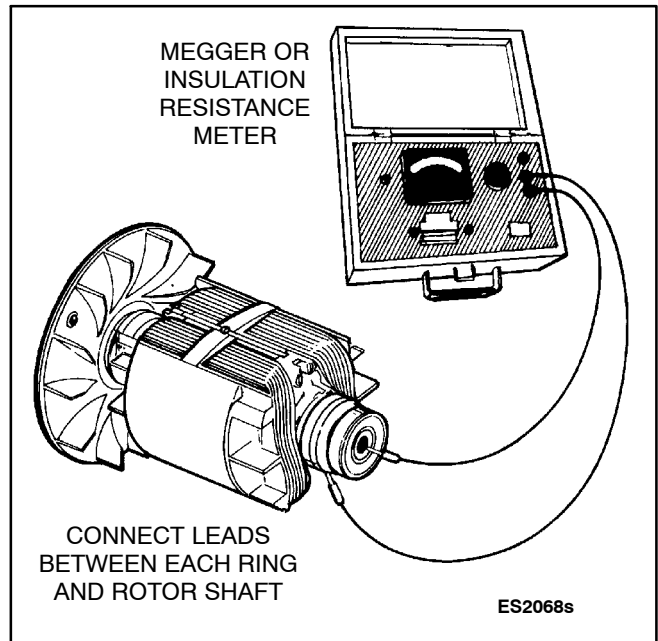

FIGURE 6-2. TESTING ROTOR FOR GROUNDS

### Testing for Grounds

Check for grounds between each slip ring and the rotor shaft, Figure 6-2. Use a Megger or insulation resistance meter which applies 500 VDC or more at the test leads. Perform test as follows:

1. Isolate the rotor windings by disconnecting the two leads to the brush holder.
2. Connect test leads between each ring and the rotor shaft in turn. Meter should register 100,000 ohms or greater.
3. If less than 100,000 ohms, rotor is questionable. Thoroughly dry the rotor and retest.
4. Replace a grounded rotor with a new identical part.

## Testing for Open or Shorted Windings

Perform this test with an accurate meter such as a digital ohmmeter.

1. Isolate the rotor windings by disconnecting the two leads to the brush holder.
2. Using ohmmeter, check resistance between F1 and F2 by connecting leads between the F1 and F2 slip rings, Figure 6-3.

Rotor resistance ( $\pm 10\%$  measured at  $25^{\circ}\text{C}$ ) are:

60 Hz:	18.2 ohms.
50 Hz:	20.7 ohms.

If there is a large difference, replace the defective rotor with a new, identical part.

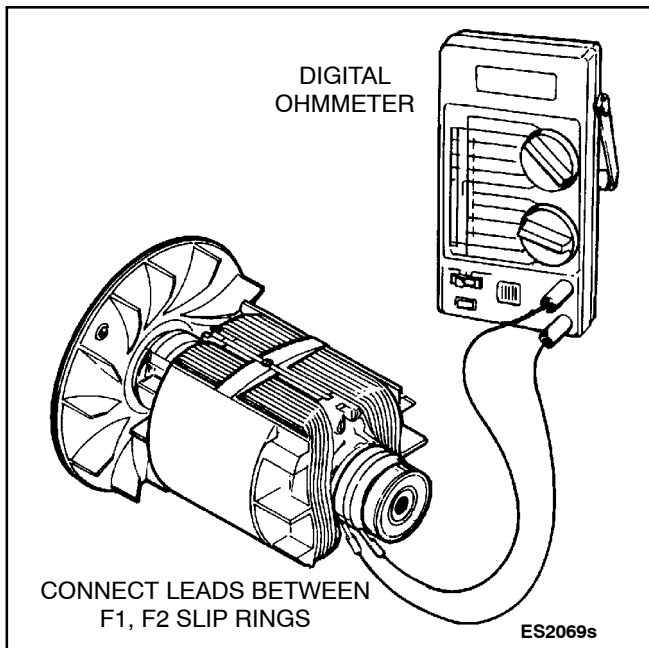

**FIGURE 6-3. TESTING ROTOR FOR AN OPEN CIRCUIT**

## [C] TESTING GENERATOR SET STATOR

Isolate the stator windings by disconnecting all six stator leads. Test for open circuits between T1-T2, T3-T4 and Q1-Q2, and for grounded circuits between T1, T3 and B1 and the stator laminations or other unpainted grounding point.

Using proper test equipment, check the stator for grounds, opens, and shorts in the windings.

### Testing for Grounds

Some generator sets have ground connections to the frame. Check wiring diagram. All stator leads must be isolated for testing.

Use a megger or insulation resistance meter which applies not more than 500 VDC to the test leads (Figure 6-4). Test each stator winding for short to laminations. A reading less than 100,000 ohms indicates a questionable stator. Thoroughly dry the stator and retest.

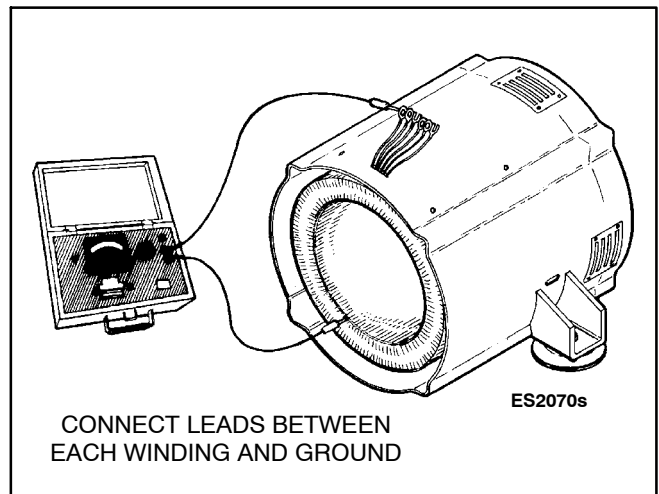

**FIGURE 6-4. TESTING STATOR WINDING FOR GROUNDS**

## Testing for Open or Shorted Windings

Test for continuity between coil leads as shown in Figure 6-5; all pairs should have equal resistance. Use an accurate instrument for this test such as a Wheatstone Bridge.

Stator resistances ( $\pm 10\%$  measured at 25° C) are:

60 Hz single-phase:

T1-T2, T3-T4: 0.216 ohm

Q1-Q60: 2.055 ohms

60 Hz single-phase (100/200 volts only):

T1-T2, T3-T4: 0.150 ohm

Q1-Q60: 2.3 ohms

60 Hz three-phase:

T1-T4, T2-T5, T3-T6

T7-T10, T8-T11, T9-T12: 0.656 ohm

Q2-T11: 0.342 ohm

50 Hz single-phase:

T1-T2, T3-T4: 0.227 ohm

Q1-Q50: 2.322 ohms

50 Hz three-phase:

T1-T4, T2-T5, T3-T6

T7-T10, T8-T11, T9-T12: 0.703 ohm

Q2-T11: 0.365 ohm

If a winding is shorted, open or grounded, replace the stator assembly. Before replacing the assembly, check the leads for broken wires or insulation.

Resistance Measurements (Q) $\pm 10\%$ At 25°C (77°F)	
Terminal Connections	A053U842 (7.5 kw)
Rotor	18.5
Main Winding T1-Gnd	.23
Main Winding T2-Gnd	.22
Main Winding T1-T2	.43
Quad Winding Q1-Q2	1.3

**Notice:** There is a consumer alternator service strategy change starting with HDKAL Spec J, alternators/serialized alternators, see below for more information

**Service Strategy Change Summary:** Beginning with HDKAL Spec J, the rotor (A) and stator (B) will no longer be orderable as individual service parts. Going forward there will be one part number for the complete alternator assembly (C). See the following Table.

	Before – Spec J & K Alternators	After – Starting with Spec K & L Alternators
Rotor	A	C (Alternator Assembly)
Stator	B	

	Before – Spec J & K Alternators	After – Starting with Spec K & L Alternators
Rotor Failure	A	C (Alternator Assembly)
Stator Failure	B	

The new Spec J (HDKAL) may have slightly different characteristics, but the overall form, fit, function, and performance will be the same as that of existing alternators. New spec alternators will be backwards compatible with old spec generator set models. However, the new spec and old spec alternator parts are not interchangeable. If a rotor or stator fails in the existing alternator, the entire alternator must be replaced with the new Spec J (HDKAL) alternator assembly.

Wiring connections and labels will remain the same as the old spec alternators.

Each new spec alternator is serialized. The serial number sticker will be located on the stator and rotor.

New spec alternators may have different cold resistive (R) values depending on model.

Bearings and slip rings will not be individually replaceable on the new spec alternators.

## [D] DYNAMIC ROTOR/STATOR TEST

The following procedure serves as a functional voltage regulator check, by determining if the problem is in the voltage regulator or in the generator set. The voltage regulator is temporarily replaced with a 12-volt battery (the generator set starting battery is usable here); 12 volts applied to the F1/F2 exciter stator should produce approximately 125 volts generator set output voltage at L1 and L2, with no load.

**⚠ WARNING** *Electrical shock can cause severe personal injury or death. Do not touch electrical wiring or components during testing. Disconnect electrical power by removing starting battery negative (-) cable before handling electrical wiring or components.*

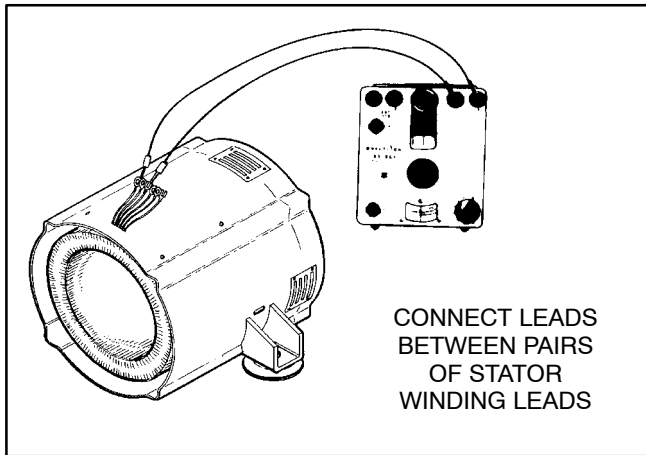

**FIGURE 6-5. TESTING STATOR WINDING RESISTANCE**

Use a sharp voltage probe and touch it carefully to the connector pins or output terminals when making these tests.

1. Stop the generator set.
2. Unplug the voltage regulator from the wiring harness.

**CAUTION** Failure to unplug the voltage regulator at this point in the procedure could lead to equipment damage.

3. Using jumpers and a spare plug or other connector, connect a 12-volt battery to the F1/F2 terminals as illustrated in Figure 6-6.
4. Start the generator set. Use a voltmeter to measure the outputs at J4-4 - J4-6, L1 - L2, L1 - L0, L2 - L0, Q60 - Q1 (50 Hz sets: Q50-Q1), and S1 - S2. The output voltages should read as follows (all voltages apply to both 50 Hz and 60 Hz sets):

- J4-4 - J4-6: 75 VAC  $\pm$  20 VAC
- L1 - L2: 147 VAC  $\pm$  20 VAC
- L1 - L0: 74 VAC  $\pm$  20 VAC
- L2 - L0: 74 VAC  $\pm$  20 VAC
- Q60 - Q1: 111 VAC  $\pm$  20 VAC
- (50 Hz sets) Q50 - Q1: 99 VAC  $\pm$  20 VAC
- S1 - S2: 75 VAC  $\pm$  20 VAC

If these voltages are measured, then the generator set is operating correctly and the problem is elsewhere.

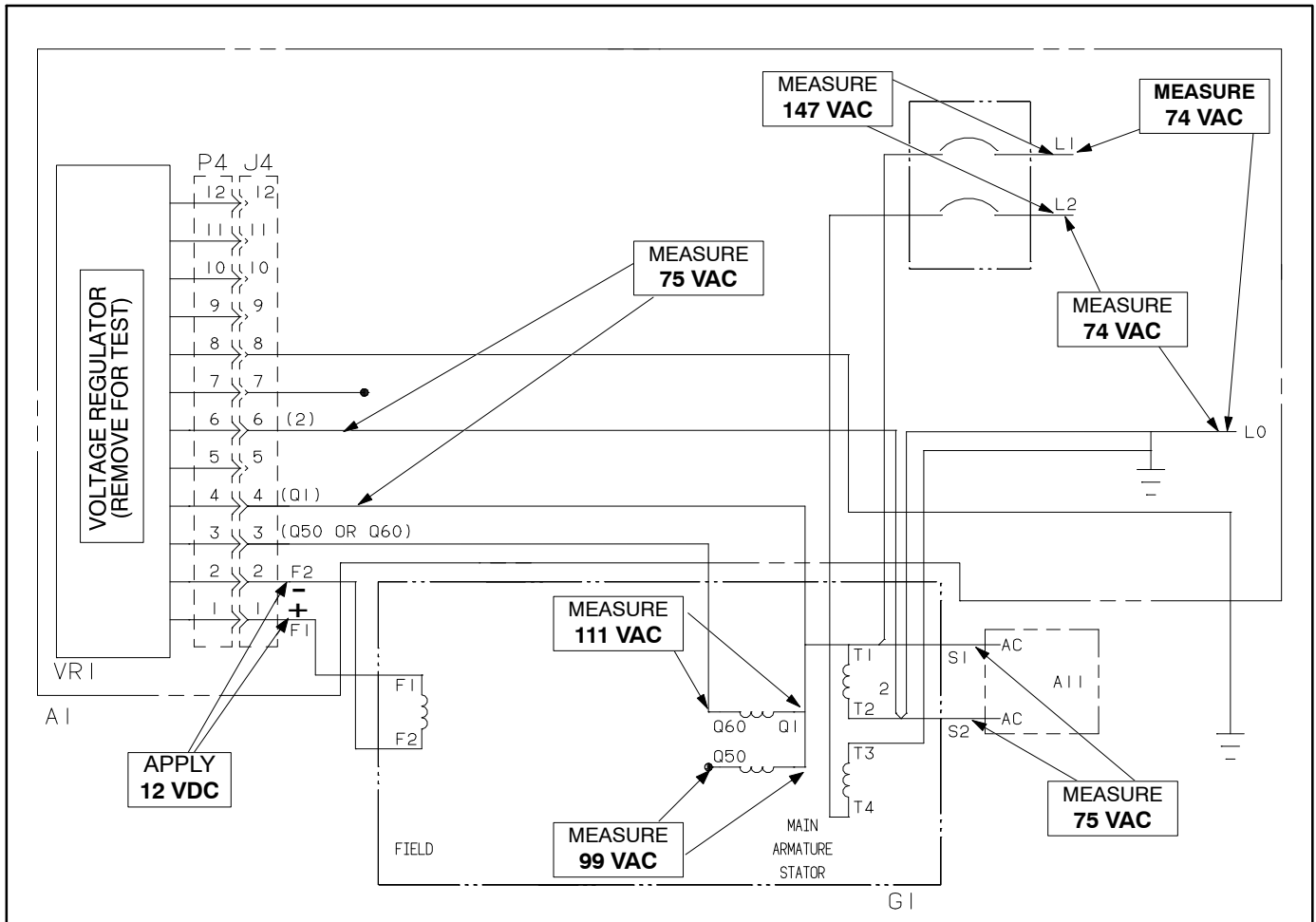

**FIGURE 6-6. DYNAMIC ROTOR/STATOR TEST**

## [E] VOLTAGE REGULATOR REPLACEMENT

Use the following procedure for replacing the AC voltage regulator assembly.

1. Stop the generator set and disconnect the starting battery leads, negative (-) lead first.
2. Unscrew the voltage regulator from the control box.
3. Disconnect the regulator from the wiring harness.
4. Remove the mounting screws from the old voltage regulator, then install the new regulator.
5. Reconnect the plug connection to the wiring harness.
6. Set voltage as outlined in [G] Voltage Adjustment.

## [F]

### WIRING HARNESS CHECK

Carefully check the wiring harness as follows:

1. Inspect all wires for breaks, loose connections, and reversed connections. Refer to applicable wiring diagram.
2. Remove wires from terminals at each end and with an ohmmeter, check each wire end to end for continuity or opens.
3. Using an ohmmeter, check each wire to other wires and to ground for possible shorts or insulation breaks under areas covered by wrapping material.
4. Reconnect or replace wires/harness according to applicable wiring diagram.

## [G]

### VOLTAGE ADJUSTMENT

This section describes adjustment of the generator set output voltage. When checking output voltage,

be sure the generator set has stabilized and is running at the correct speed (frequency). The regulator is adjusted with the set running.

**⚠WARNING** *Accidental starting of the set can cause severe personal injury or death. Disconnect both battery cables, negative (-) cable first, when repairs are made to the engine, controls, or generator set.*

**⚠WARNING** *Contact with high voltage can cause severe personal injury or death. Do not touch any exposed wiring or components with any part of the body, clothing, tool or jewelry. Do not use non-insulated tools inside the control. Stand on an insulating mat or dry wood platform when the control doors are open.*

Output voltage adjustments are found on the voltage regulator board under the DC control box. A removable cover protects the board. See Figure 6-7.

1. Attach a voltmeter securely to the L1 and L2 leads.
2. Start the generator set and place a typical load on its output.
3. Use a flat-blade screwdriver to set the voltage adjust potentiometer for correct voltage.

For most 60 Hz applications, the ideal setting is 120 VAC at 60-61 hz, measured at the power input of the application. Retighten the locking nut when complete.

**Note that the voltage adjustment pot on the voltage regulator board is a 10-turn potentiometer: it may take several turns to change the voltage noticeably.**

## [H]

### RECONNECTION

generator set reconnection is dependent upon the nameplate code. See Section 8.

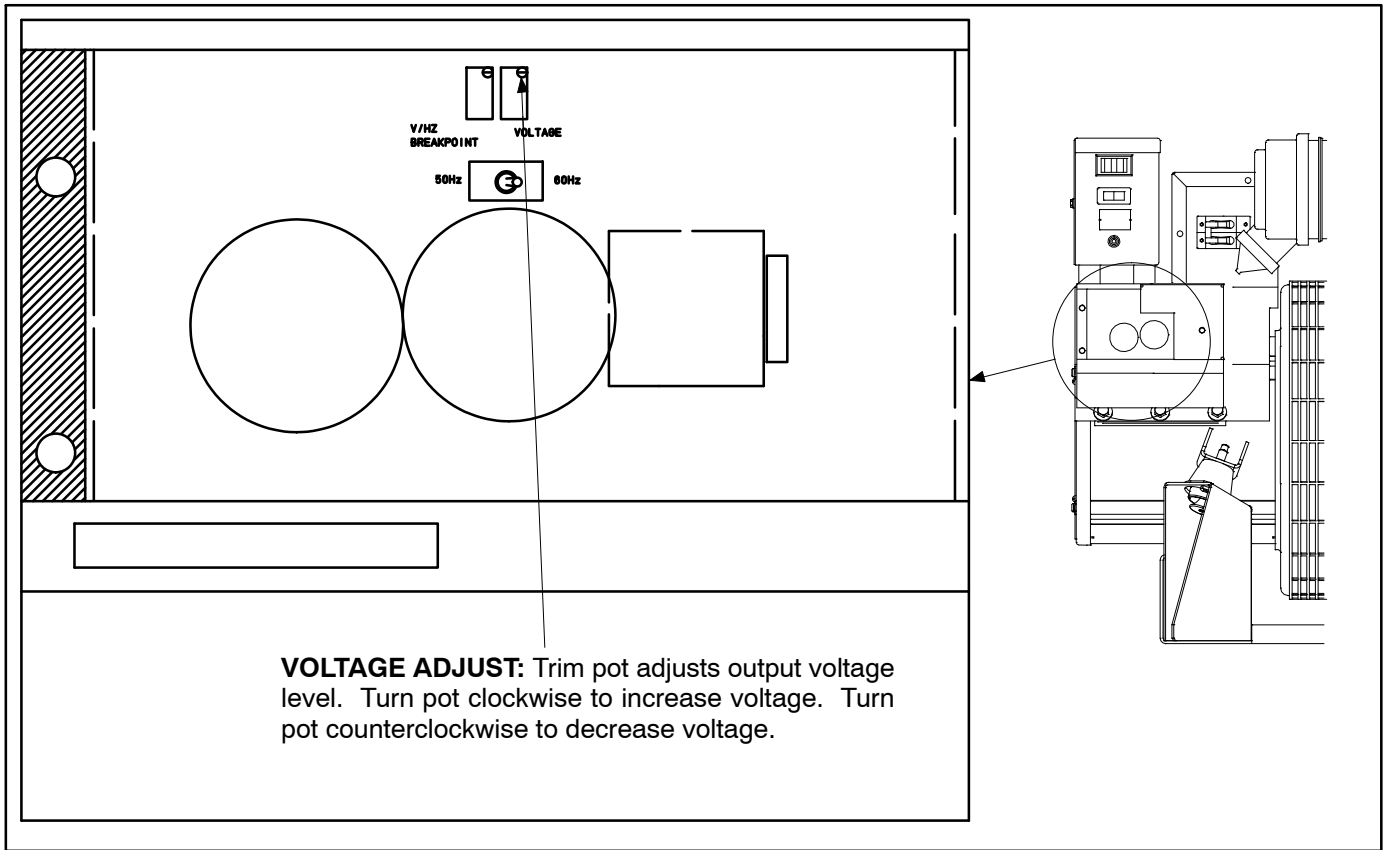

**FIGURE 6-7. LOCATION, OUTPUT VOLTAGE ADJUSTMENT**



# 7. Periodic Maintenance

Periodic maintenance is essential for top generator set performance and long service life. Use Table 7-1 as a guide, follow *Maintenance Procedures* and record maintenance performed in *Maintenance Record*.

**⚠WARNING** *Accidental starting can cause severe personal injury or death. Disconnect the negative (-) cable(s) at the battery(ies) to prevent starting while working on the generator set.*

**TABLE 7-1. PERIODIC MAINTENANCE SCHEDULE**

PROCEDURE	FREQUENCY								Page
	After first 50 Hr	Every Day/ 8 Hr	Every 50 Hr	Every Month/ 100 Hr	Every 6 Month/ 250 Hr	Every Year/ 500 Hr	Every 2 Years	Every 5 years	
Inspect generator set		x <sup>1</sup>							7-2
Check Oil Level		x							7-2
Check Coolant Level		x							7-2
Check Fuel Level		x							7-2
Clean Air Cleaner Dust Boot			x <sup>5</sup>						7-5
Check Battery				x <sup>2</sup>					7-4
Check V-Belt Tension				x <sup>3</sup>					7-6
Drain Water in Fuel				x <sup>4</sup>					7-8
Change Engine Oil and Oil Filter	x			x <sup>5</sup>					7-3
Change Fuel Filter					x <sup>7</sup>				7-8
Change Air Cleaner Element						x <sup>5</sup>			7-5
Change Coolant						x			7-6
Adjust Valve Lash						x <sup>6</sup>			-
Replace Pressure Cap							x		7-6
Replace Generator Bearing								x <sup>6</sup>	-

1 – Check for oil, fuel, coolant and exhaust system leaks.  
 2 – See battery manufacturer’s recommendations.  
 3 – Check for slippage.  
 4 – Drain about one cup to remove water and sediment.  
 5 – Perform more often in dusty conditions.  
 6 – Must be performed by an authorized Cummins dealer.  
 7 – Perform every 250 hours when using B20 Bio–diesel fuel.

## GENERAL INSPECTION

Perform these checks and inspections every time the generator set is started or every eight hours if the generator set is being run continuously.

### Oil Level Check

**⚠ WARNING** *Crankcase pressure can blow out hot oil and cause severe burns. Stop the engine before checking the oil level or opening the fill cap.*

Shut down the generator set to check engine oil level and wait a few minutes for the oil to drain down to the crankcase to get an accurate indication of oil level.

Keep the oil level between FULL and ADD on the dipstick (Figure 7-1). See ENGINE OIL RECOMMENDATIONS for the oil to use.

**⚠ CAUTION** *Too little oil can lead to severe engine damage and too much oil to high oil consumption and foaming, which can cause engine shutdown. Keep the oil level between FULL and ADD.*

### Coolant Level Check

Replenish the normal loss of coolant by keeping the level in the coolant recovery tank between COLD and HOT. See COOLING SYSTEM for the recommended mixture of antifreeze and if it is necessary to refill the system.

### Exhaust Leaks

Look and listen for exhaust system leaks while the generator set is running. Shut down the generator set if a leak is found and have it repaired before operating the generator set.

Look for openings or holes between the generator set compartment and vehicle cab or living space if the generator set engine sounds louder than usual. Have all such openings or holes closed off or sealed to prevent exhaust gases from entering the vehicle.

Replace dented, bent or severely rusted sections of the tailpipe and make sure the tailpipe extends at least 1 inch (25.4 mm) beyond the perimeter of the vehicle.

Park the vehicle so that the generator set exhaust gases can disperse away from the vehicle. Barriers such as walls, snow banks, high grass, brush and

other vehicles can cause exhaust gases to accumulate in and around the vehicle.

To avoid drawing exhaust gases into the vehicle, do not turn on power ventilators or exhaust fans when the generator set is running and the vehicle is standing still.

**⚠ WARNING** *EXHAUST GAS IS DEADLY! Do not operate the generator set if there is an exhaust leak or any danger of exhaust gases entering or being drawn into the vehicle.*

**⚠ WARNING** *Do not park the vehicle in high grass or brush. Contact with the exhaust system can cause a fire.*

### Fuel System Inspection

Check for leaks at all fuel line fittings and gaskets. Replace fuel hose that has been abraded or cut and install new hose in such a way that it will not become kinked, rub against other parts or come in contact with sharp edges, hot surfaces or wiring.

**⚠ WARNING** *Fuel leaks can lead to fire. Repair leaks immediately. Do not run the generator set if it causes fuel to leak.*

Prime the fuel system if the generator set ran out of fuel or a fuel filter was replaced. See FUEL SYSTEM.

### Battery Inspection

Check for clean, tight battery connections. Loose and corroded connections make for hard starting because of high electrical resistance. See BATTERIES.

**⚠ WARNING** *Arcing at battery terminals or in a light switch or other equipment, flames and sparks can ignite battery gas causing severe personal injury. Ventilate the battery compartment before connecting or disconnecting battery cables—Disconnect the negative (-) cable first and reconnect it last—Wear safety glasses—Do not smoke—Switch lights ON and Off away from the battery.*

### Mechanical Inspection

Check for unusual noises and vibrations, loose generator set mounts and signs of mechanical damage. Check the engine gauges regularly (if provided) while the generator set is running. See *Operation* for normal gauge readings.

Keep the generator set clean. Do not clean the generator set while it is running. Protect the generator, control panel, and electrical connections from cleaning solvents. Remove the generator endbell cover and use compressed air to blow dust out of the generator and radiator core.

**⚠WARNING** *Wear safety glasses when using compressed air to prevent eye injury.*

## CHANGING OIL AND OIL FILTER

**⚠WARNING** *State and federal agencies have determined that contact with used engine oil can cause cancer or reproductive toxicity. Take care to limit skin contact and breathing of vapors. Use protective gloves and wash exposed skin.*

See Table 7-1 for frequency of maintenance.

**⚠WARNING** *Crankcase pressure can blow out hot oil and cause severe burns. Stop the engine before checking the oil level or opening the fill cap.*

**Draining Engine Oil:** To drain the engine oil, run the engine until thoroughly warm and stop it. Open either the side or bottom service access door to get at the oil drain valve and oil filter (Figure 7-1). Drain

the oil into a suitable container and **close the valve when the oil has completely drained.**

**Changing Oil Filter:** To change the oil filter, place a container under the oil filter (Figure 7-1) to catch oil that drips out and then spin off the oil filter. Clean the filter mounting surface (making sure to remove the old gasket), apply oil to the new filter gasket and spin the filter on until the gasket just touches the mounting pad. Then tighten an additional 3/4 turn.

**Refilling Engine Oil:** See ENGINE OIL RECOMMENDATIONS for the oil to use and *Specifications* for the amount. Refill with the proper amount of oil, start the engine and check for leakage around the filter gasket. **Tighten the filter only enough to stop leakage.** Shut off the generator set, recheck the oil level and add oil as necessary. Secure the access door.

**⚠CAUTION** *Too little oil can lead to severe engine damage and too much oil to high oil consumption and foaming, which can cause engine shutdown. Keep the oil level between FULL and ADD.*

**Disposing of Used Oil and Oil Filter:** Dispose of the used oil and oil filter according to local environmental regulations.

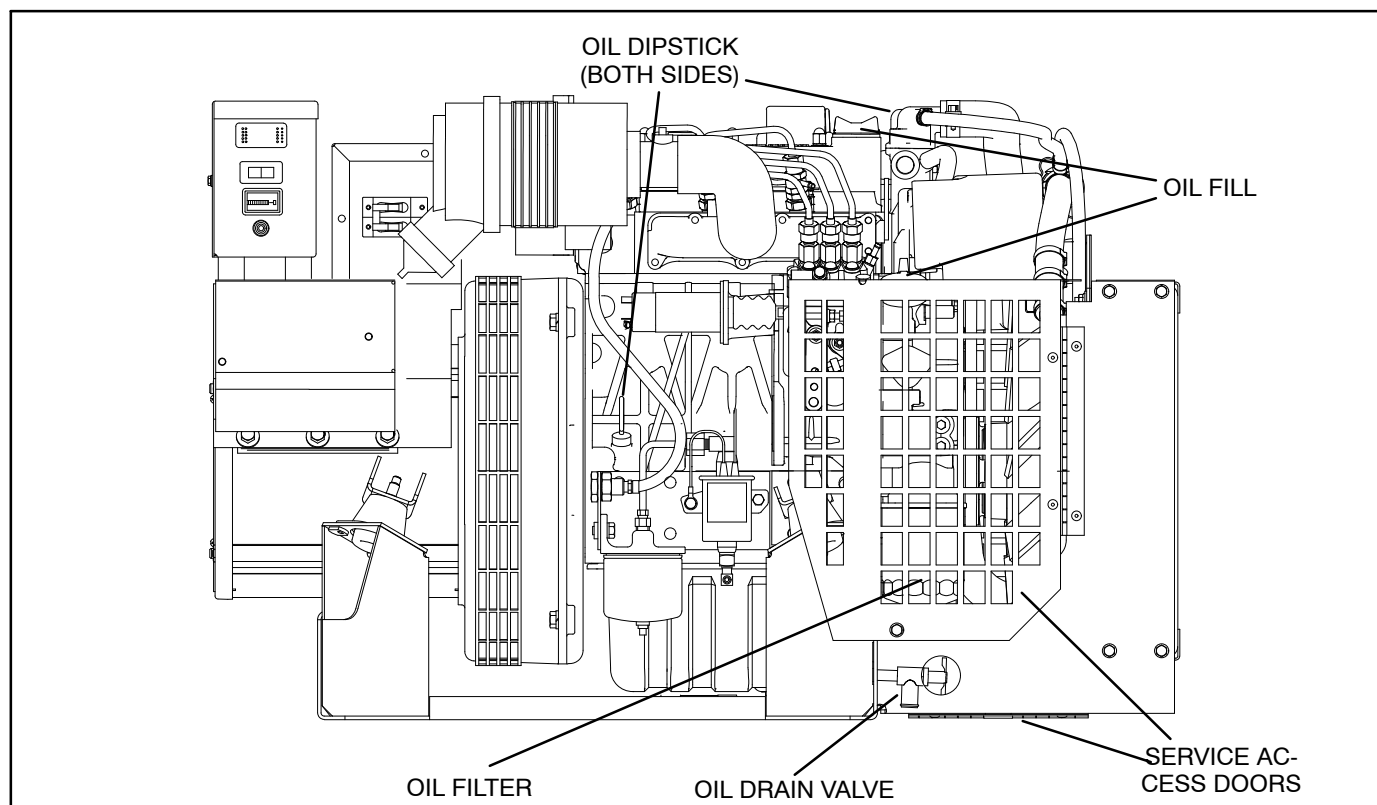

**FIGURE 7-1. OIL CHECK, FILL, DRAIN AND FILTER**

## AIR CLEANER MAINTENANCE

See Table 7-1 for frequency of maintenance. The air cleaner element must be handled carefully and must never have oil applied to it. Before changing the filter element, squeeze the dust boot to release any trapped dust. Install the new filter element as follows:

1. Unclip the cover (Figure 7-2) and pull the filter element out gently to reduce the amount of dust dislodged. Gently twist or move the element side to side to disengage the seal and pull it out.
2. Clean the sealing surface and inside of the outlet tube to keep dust and dirt from entering the engine.
3. Examine the old filter element for dust on the clean-air side of the element. This could indicate leakage on the sealing surface. Correct as necessary.
4. Inspect the new element for damage. *Do not install a damaged element.* Insert the new element into the housing, applying pressure at the outer rim of the element and not on its flexible center, and secure the cover.

## SPARK ARRESTER CLEANING

It may be necessary to clean out the spark arrester if the generator set is experiencing low power. Park the vehicle away from grass, brush or debris that could be ignited by sparks expelled during this procedure. The spark arrester meets U.S. Forest Service requirements. To clean the spark arrester, remove the 1/8 inch pipe plug in the bottom of the muffler and run the generator set for five minutes at full load. Replace the plug when the muffler has cooled down. See Figure 7-3.

## BATTERIES

See Table 7-1 for frequency of maintenance. Sealed, maintenance-free batteries are recommended. Follow the manufacturer's instructions for battery care. Keep the terminals clean and tight.

**⚠WARNING** *Arcing at battery terminals or in a light switch or other equipment, flames and sparks can ignite battery gas causing severe personal injury. Ventilate the battery compartment before connecting or disconnecting battery cables—Disconnect the negative (-) cable first and reconnect it last—Wear safety glasses—Do not smoke—Switch lights ON and Off away from the battery.*

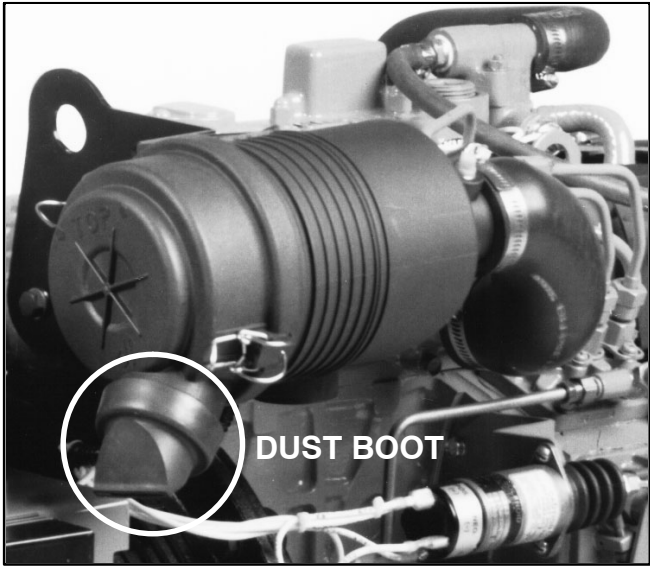

**FIGURE 7-2. AIR CLEANER ASSEMBLY**

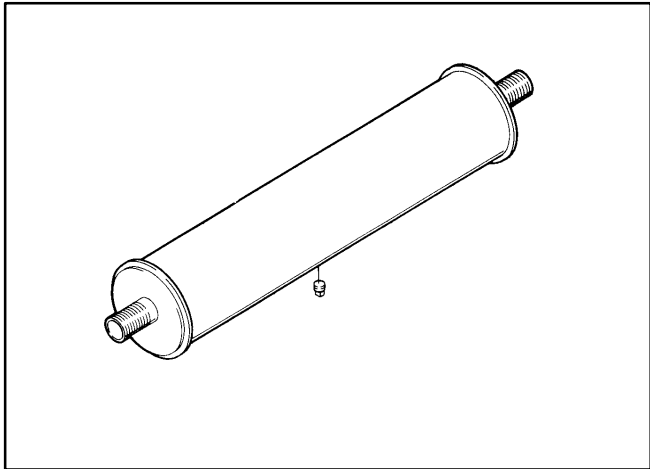

**FIGURE 7-3. SPARK ARRESTER WITH CLEANOUT PLUG**

## ENGINE COOLING SYSTEM

See Table 7-1 for frequency of maintenance.

### Cooling System Overview

The engine is cooled by a pressurized, closed-loop liquid cooling system. Coolant is pumped through passages in the engine block and head and is cooled in a generator set-mounted radiator. The radiator fan is arranged to either pull or push air through the radiator.

### Recommended Coolant Mixture

Use the best quality ethylene or propylene glycol antifreeze solution available. It should be fully formulated with rust inhibitors and coolant stabilizers **but not with stop-leak additives**. Use fresh water that is low in minerals and corrosive chemicals. Distilled water is best. Unless prohibited by shipping regulations, generator sets are shipped with the recommended 50/50 mixture of water and ethylene glycol, which is good for -34°F (-37°C).

### Adjusting V-Belt Tension

See Table 7-1 for frequency of maintenance. The V-belt (Figure 7-4) drives the coolant pump and battery charging alternator. (The radiator fan is mounted on the crankshaft pulley and therefore is not driven by the belt.)

**⚠WARNING** *Accidental starting can cause severe personal injury or death. Disconnect the negative (-) cable(s) at the battery(ies) to prevent the engine from starting.*

1. Disconnect the negative (-) cable(s) at the battery(ies) to prevent the engine from starting and remove the top belt guard.
2. Loosen the alternator pivot bolt first and then the adjusting bracket bolt on top.
3. Tighten belt tension by pivoting the alternator outwards. Hold tension by tightening the adjusting bracket bolt. Apply 20 pounds (10 kg) as shown to the middle of the pulley span and measure belt deflection, which should be 0.4 inch (10 mm). Tighten the alternator bolts when tension is correct.
4. Secure the belt guard and reconnect the battery cables (negative [-] last).

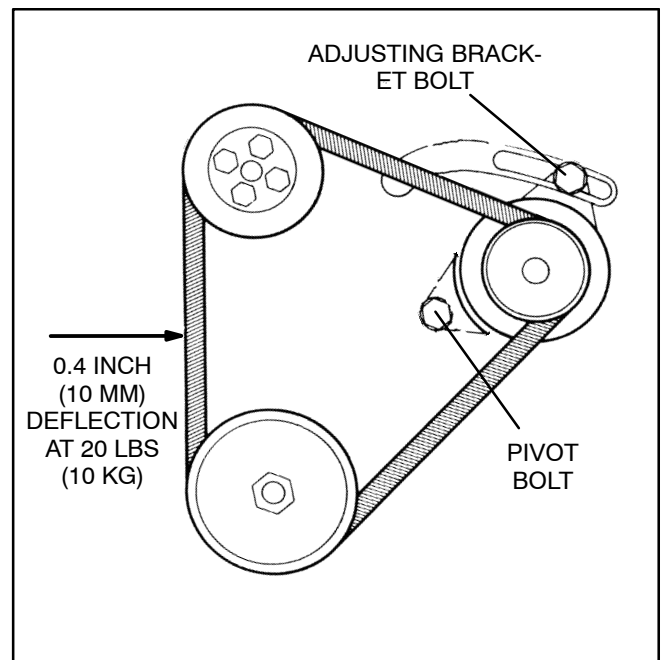

FIGURE 7-4. ADJUSTING V-BELT TENSION

## Pressure Cap

See Table 7-1 for frequency of replacement. Replace the pressure cap as recommended to maintain optimal engine cooling and minimal coolant loss.

## Coolant Recovery Tank

Replenish the normal loss of coolant by keeping the level in the recovery tank between COLD and HOT. Use the recommended mixture of antifreeze. See Changing Coolant if it is necessary to fill the system.

## Changing Coolant

**⚠️ WARNING** *Hot coolant is under pressure and can cause severe burns when loosening the pressure cap. Let the engine cool before loosening the pressure cap.*

**⚠️ WARNING** *Accidental starting can cause severe personal injury or death. Disconnect the negative (-) cable(s) from the battery(ies) to prevent the engine from starting.*

**Draining the System:** Let the engine cool down, disconnect the negative (-) cable(s) at the battery(ies) to prevent the engine from starting, re-

move the system pressure cap and open the block and radiator drain valves (Figure 7-5). Collect used coolant in containers for proper disposal.

**⚠️ WARNING** *Ethylene glycol antifreeze is considered toxic. Dispose of it according to local regulations for hazardous substances.*

**Cleaning and Flushing the System:** Use radiator cleaning chemicals to clean and flush the cooling system before new coolant is added. Follow the manufacturer's instructions.

**⚠️ CAUTION** *Filling a hot engine with cold water can cause cracks in the manifold, head and block. Follow the manufacturer's instructions for cleaning and flushing.*

**Filling the System:** Close all drain valves and secure all hose clamps and fill the system through the fill opening, holding the fill hose vertical. The system will fill only as fast as the air can escape. Start and run the engine for a minute to dislodge air pockets and shut it down. Add as much coolant as necessary to fill up the tube and secure the pressure cap.

**⚠️ CAUTION** *Low coolant level can cause severe engine damage. Make sure the system is full.*

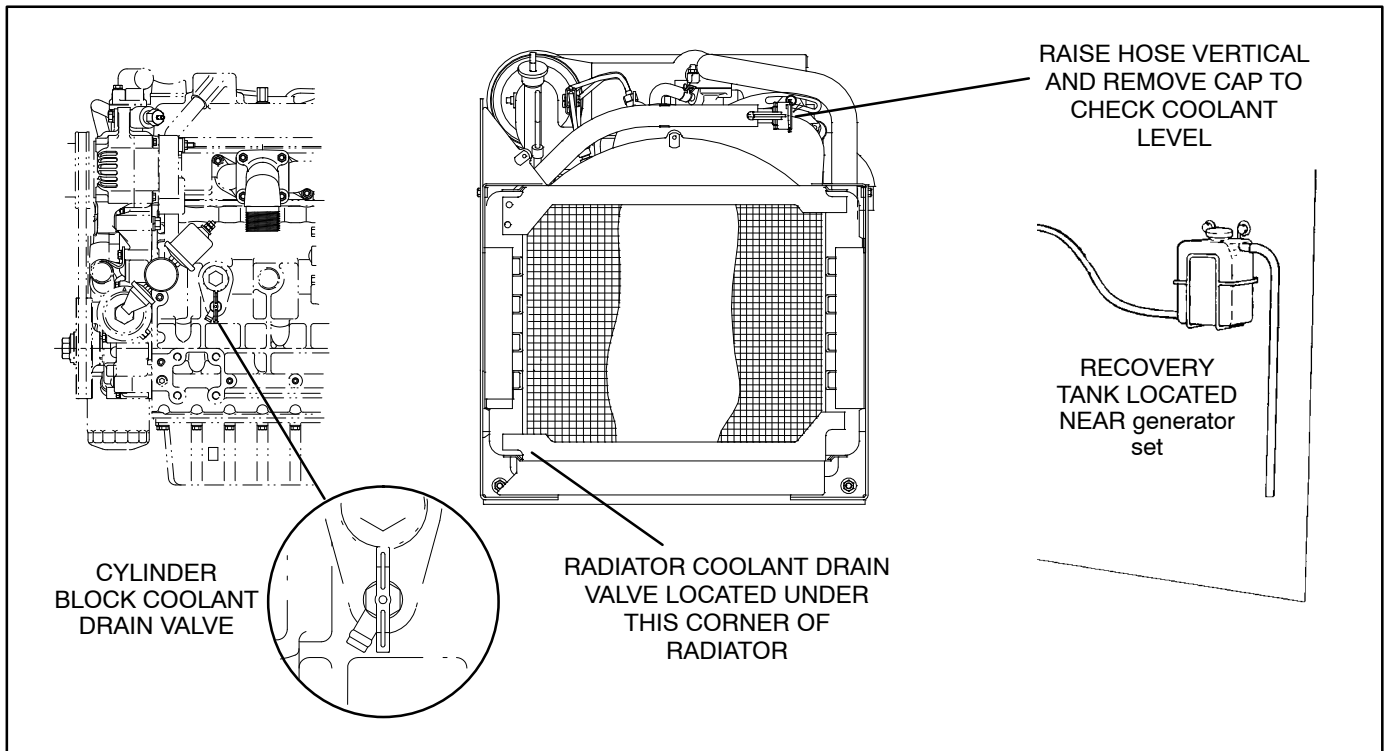

FIGURE 7-5. COOLING SYSTEM

## FUEL SYSTEM

### Fuel Handling Precautions

Keep dirt, water and other contaminants from entering the fuel system and damaging, corroding or clogging fuel injection components. The generator set has a water-separator type of fuel filter.

A primary source of water in fuel, which can clog fuel passages by freezing and cause corrosion by forming sulfuric acid with the sulfur in the fuel, is the condensation of humid air on the walls of the fuel tank. Keeping fuel tanks as full as possible reduces condensation by reducing the area on which condensation can take place.

### Fuel Filter

**Draining Water and Sediment:** See Table 7-1 for frequency of maintenance. Drain more often if fuel quality is poor or condensation cannot be avoided. To drain the filter, remove the plug (Figure 7-6), col-

lect the water and sediment (about 1/2 cup [120 ml]) in a suitable container and dispose of properly. **Reinstall the plug securely.**

**Replacing the Filter Element:** See Table 7-1 for frequency of maintenance. Replace the filter sooner if the engine lacks power or surges.

1. Drain the filter as explained above and spin off the element.
2. Clean the contact surface of the base.
3. Lubricate the new element and its gasket, and fill the element with clean diesel fuel.
4. Spin the new element onto the base and hand tighten.
5. Start and run the generator set and check for fuel leakage. Tighten the filter only enough to stop leakage. See Priming the Fuel System if the generator set does not start.

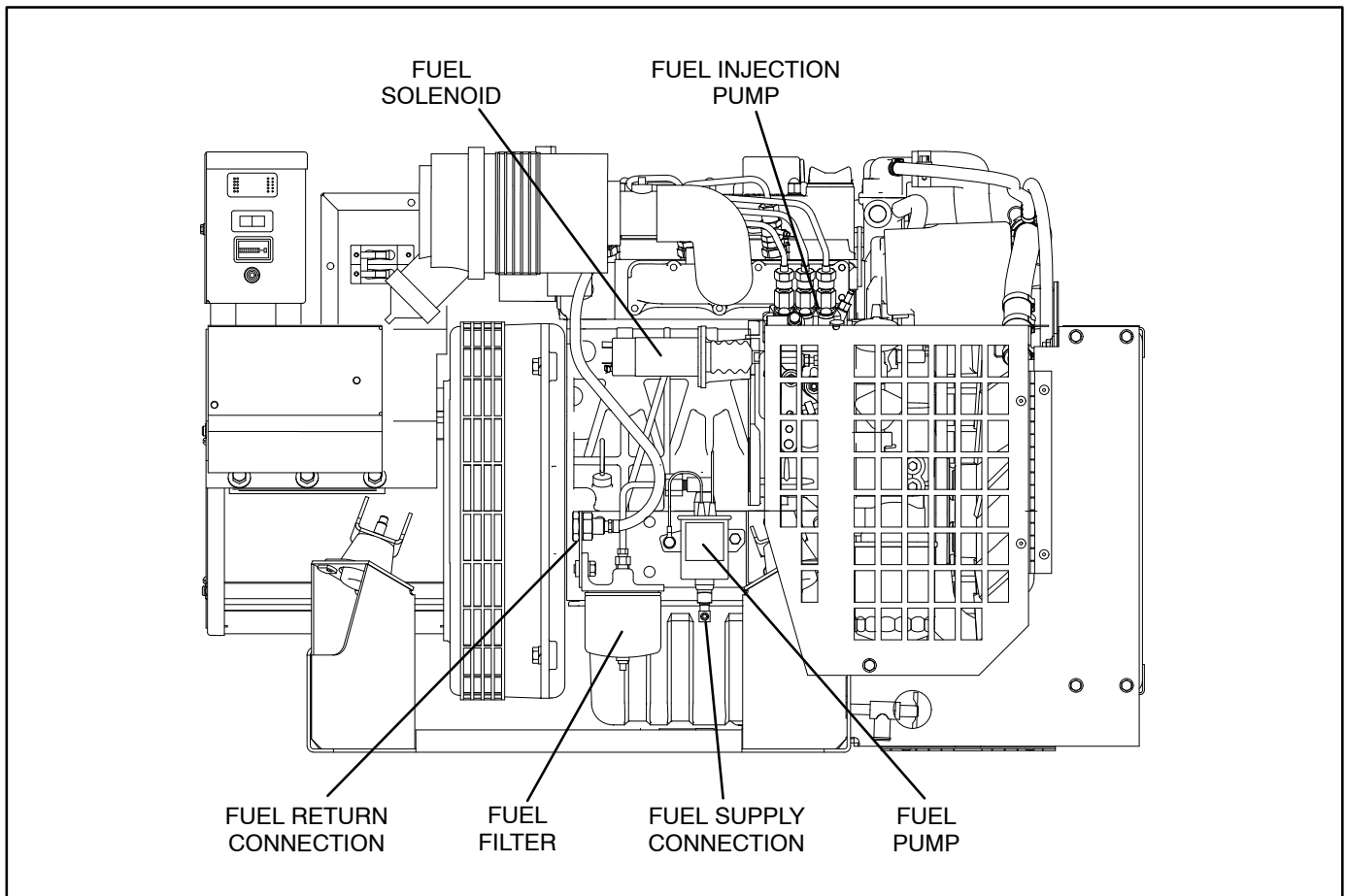

FIGURE 7-6. FUEL SYSTEM



## Priming the Fuel System

**Priming the Low-Pressure Side:** The fuel lift pump is usually able to prime the low-pressure side during cranking. If the engine does not start after two tries (15 second crankings with a two minute rest between crankings), jumper the fuel lift pump directly to the 12 VDC cranking battery and let the pump run for a few minutes to make sure the fuel lines, fuel filter and injection pump have been purged of all air. (The air and fuel are returned to the fuel tank. There are no bleed screws to open.)

**Note:** If the generator set has been mounted at an elevated location on the vehicle, the vehicle manufacturer probably has provided an auxiliary fuel pump and solenoid shutoff valve which must also be energized during priming. Check with the vehicle manufacturer if it is not clear as to how the auxiliary pump and solenoid should be energized.

**Priming the High-Pressure Side:** This procedure should only be performed by a diesel mechanic.

**⚠WARNING** *The high pressure oil spray from an injector line fitting can penetrate the skin, leading to possible blood poisoning. Wear safety glasses and keep your hands away from the spray. Do not delay getting proper medical attention if oil spray penetrates your skin.*

1. Loosen the high pressure fittings at the nozzles. Use two wrenches to keep from twisting the return fittings. Use flare-nut wrenches to keep from rounding the shoulders.
2. Crank the generator set until fuel appears at the loosened fittings and then snug up each fitting. The engine should start and run when the first fitting is snugged.
3. Shut down the engine and torque the fittings to 19 – 25 lb-ft (25 – 34 N-m).

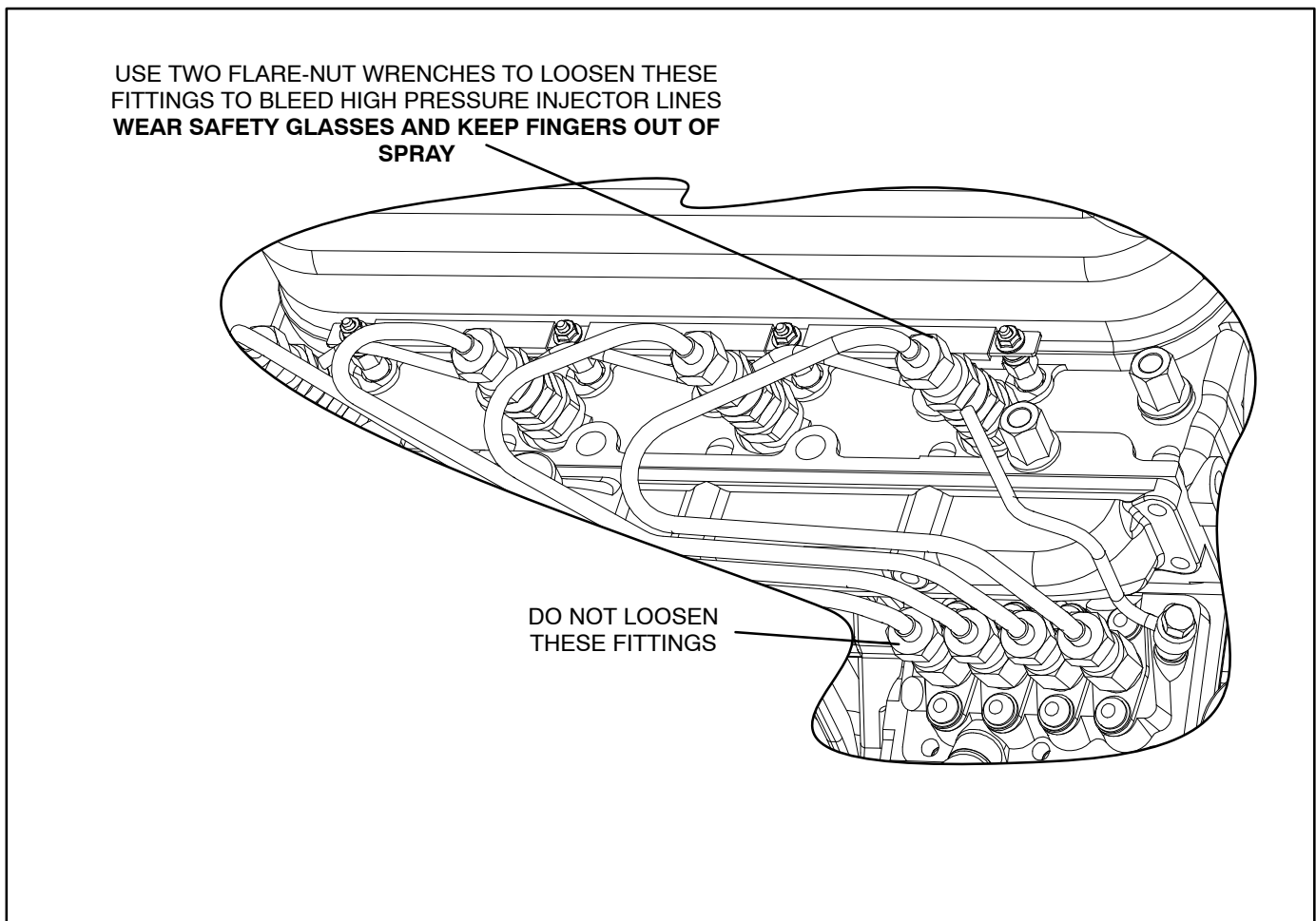

FIGURE 7-7. PRIMING THE HIGH-PRESSURE FUEL INJECTION SYSTEM

## BIO-DIESEL FUELS B5 – B20

B5 bio-diesel fuel that meets industry specifications and quality is suitable for use with this generator set.

### Bio-Diesel Above B5 and up to B20 Bio-Diesel Blends

The following must be verified before using bio-diesel blends up to B20:

- For model HDKAL, the generator set is at Spec G or higher.
- The vehicle propulsion engine is capable of using B20 when sharing the same fuel tank.
- The OEM has installed B20 compatible fuel line from fuel tank to generator set.
- The OEM has installed a water separator in the fuel line just before the generator set.

#### Approved Bio-Diesel Fuel:

- For bio-diesel blends above B5 and up to B20, Cummins requires that the fuel meet the specifications outlined in ASTM D7467.
- The bio-diesel component of this fuel blend must meet ASTM D6751 or EN14214 and the petroleum-diesel component must meet ASTM D975.
- Blended bio-diesels fuels should be bought pre-blended and not made by customers.

#### Bio-Diesel Properties:

- Bio-diesel has poor oxidation stability which can accelerate fuel oxidation. Fuel oxidation will reduce generator performance. This effect is accelerated at increased ambient temperatures.
- Bio-diesel properties change at low ambient temperatures (below 23°F/-5°C). Necessary

precautions must be taken when operating the generator with bio-diesel blends in low ambient temperatures, such as a fuel heater, hose insulation, or additional anti-gel fuel additives.

- Bio-diesel fuel blends are an excellent medium for microbial growth. Microbes cause fuel system corrosion and premature filter plugging. The effectiveness of all commercially available conventional anti-microbial additives, when used in bio-diesel, is not known. Consult your fuel and additive supplier for assistance.

**⚠WARNING** It is highly recommended that specific market applications are avoided or exercised with extra care due to some of the properties of bio-diesel fuel blends such as cold weather operation, long term storage, material incompatibilities and other effects on engine operating characteristics. Such applications that should use standard fuels include applications that will experience seasonal usage, storage for periods exceeding 90 days, and extreme temperatures or humidity.

#### Storage Requirements:

- If using bio-diesel for seasonal applications (stored more than 90 days), the generator must be purged before storage by running the engine on pure diesel fuel meeting ASTM D975 for a minimum of 30 minutes.

#### Warranty Coverage:

Cummins warranty covers failures that are a direct result of defects in material or factory workmanship. Generator damage, service issues and/or performance issues determined by Cummins to be caused by bio-diesel fuel blends not meeting the specifications outlined in the applicable Installation, Operator, and Service Manuals are not considered to be defects in material or workmanship and may affect your generator's warranty.

# 8. Wiring Diagrams

---

The electrical schematics and wiring diagrams that apply to the generator set covered in this manual are listed below.

<b>WIRING DIAGRAM</b>	<b>DRAWING NO.</b>	<b>PAGE</b>
DC Wiring Diagram .....	612-6689 .....	8-3
Single Phase Generator Diagram .....	612-6637 .....	8-4
Three Phase Generator Diagram .....	612-6732 .....	8-5

**THIS PAGE IS INTENDED TO BE BLANK**



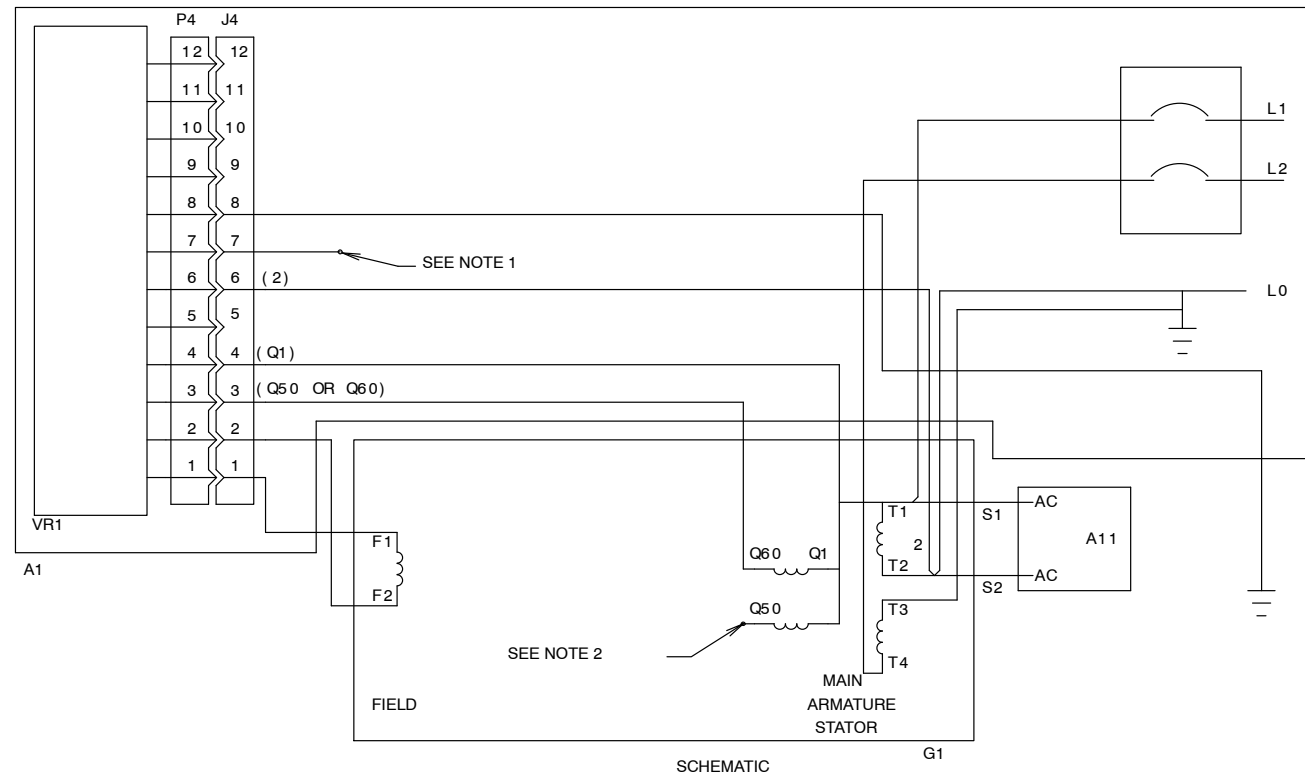

S1 AC  
S2 AC  
A11  
L1  
L2  
L0  
SEE NOTE 1  
(2)  
(Q1)  
(Q50 OR Q60)  
VR1  
A1  
F1  
F2  
FIELD  
MAIN ARMATURE  
STATOR  
G1  
T1  
T2  
T3  
T4

SCHMATIC

110/220V, 115/230V & 120/240V AS SHOWN  
SEE RECONNECTI ON CHART FOR OTHER VOLTAGES

REF DES	PART NO	DWG SIZE	QTY	DESCRIPTION
1	---	---	1	WIRE HARNESS
2	---	---	1	LEAD (F1)
3	---	---	1	LEAD (F2)
G1	---	---	1	GENERATOR
VR1	---	---	1	VOLTAGE REG-CAP AVR

- NOTE:
1. FROM J2-15 FOR FIELD FLASHING.
  2. QUADRATURE POWER CONNECTION Q60-60 HZ, Q50-50 HZ UNITS.
  3. AVR REFERENCE VOLTAGE.

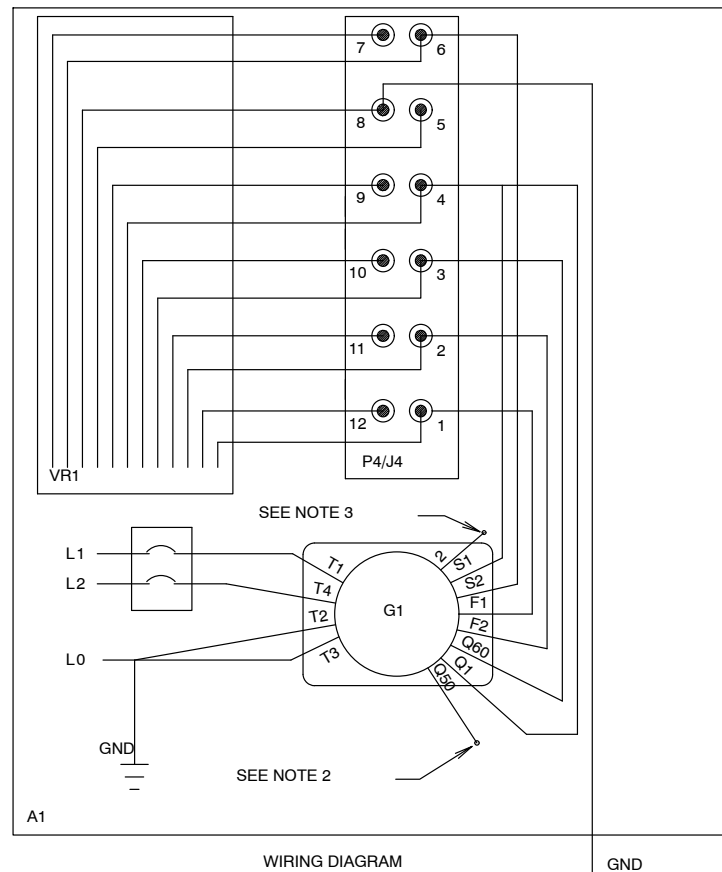

WIRING DIAGRAM

110/220V, 115/230V & 120/240V AS SHOWN  
SEE RECONNECTI ON CHART FOR OTHER VOLTAGES

	A	B	C	HZ	CODE
VOLTAGE	100 120	200 240	100/200 120/240	60	J
	110 115	220 230	110/220 115/230	50	P
SCHEMATIC					
	RECONNECTION CHART				

SINGLE-PHASE GENERATOR DIAGRAMS

AC WIRING DIAGRAM-ELECTRONIC REGULATION CODE L, Z

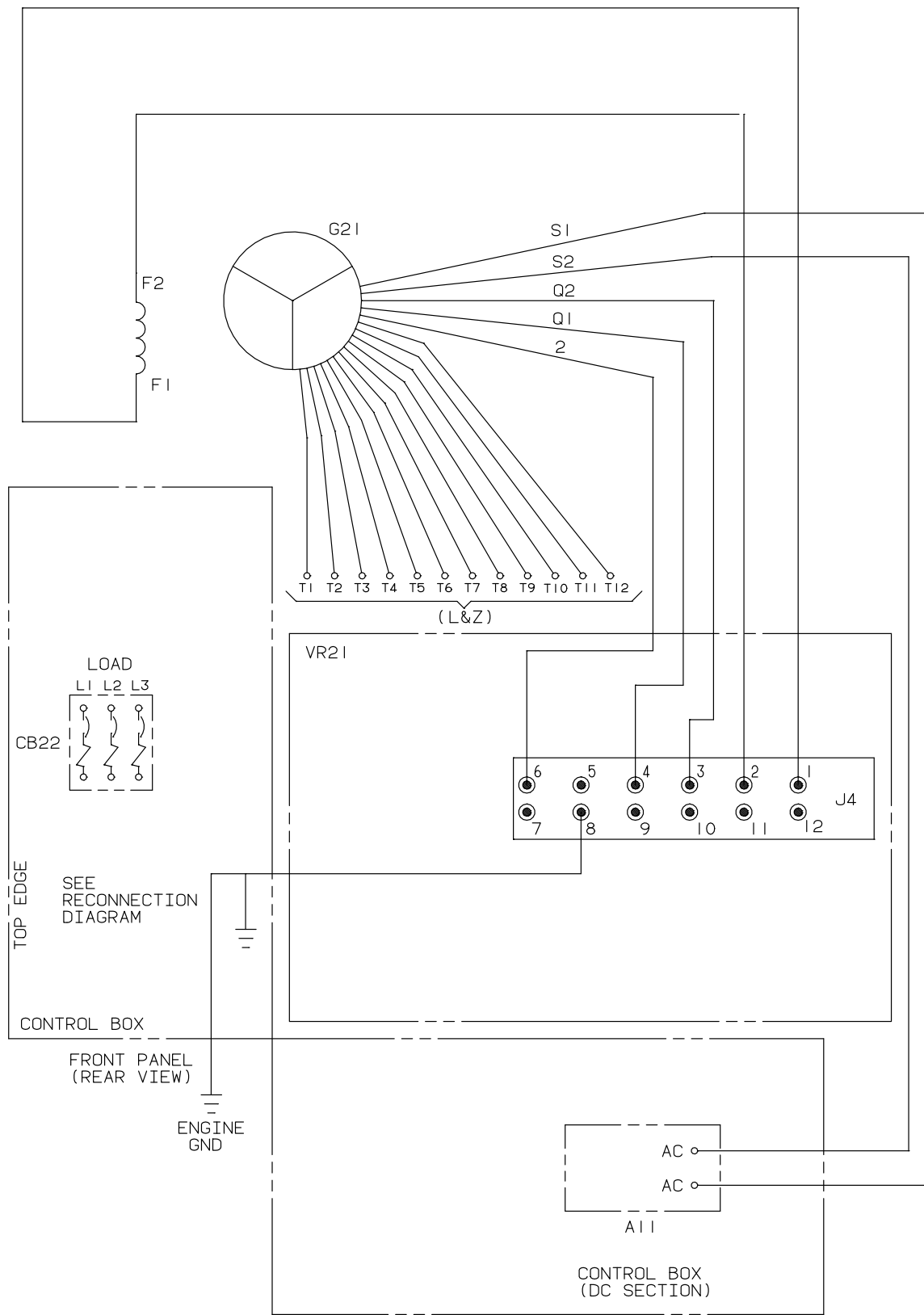

AC SCHEMATIC-ELECTRONIC REG VOLTAGE CODES (L&Z)

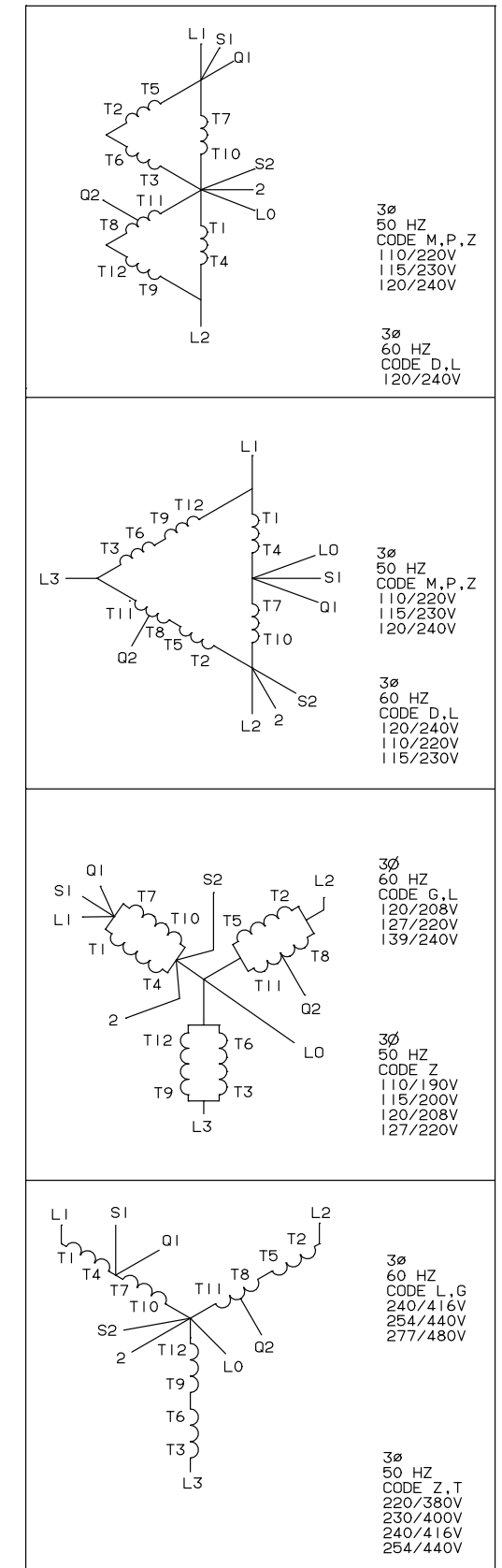
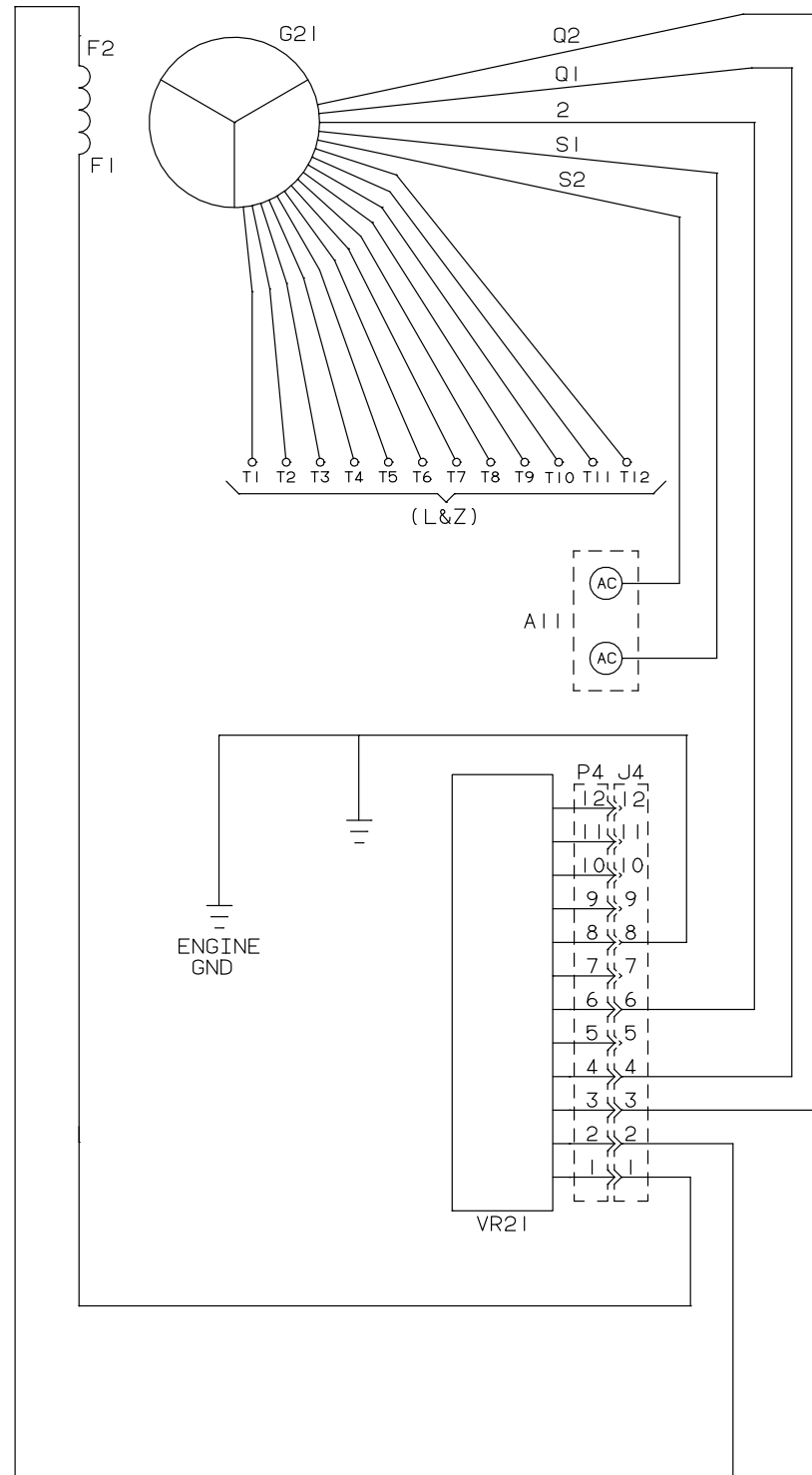

NOTE:

1. UNLESS OTHERWISE NOTED, ALL COMPONENTS ARE SHOWN IN DE-ENERGIZED POSITION.
2. DASHED LINES INDICATE CONNECTIONS WHEN USED.
3. INSULATE ALL UNUSED OR INTERCONNECTED GENERATOR LEADS WITH SLEEVING AND SECURE WITH CABLE TIE

THREE-PHASE GENERATOR DIAGRAMS

**THIS PAGE IS INTENDED TO BE BLANK**





[power.cummins.com](http://power.cummins.com)

Copyright © 2019 Cummins Inc. All rights reserved.

Cummins, Onan, and the "C" logo are registered trademarks of Cummins Inc. and its subsidiaries.

Other company, product, or service names may be trademarks or service marks of others.

Specifications are subject to change without notice.

