



Parts Manual

Onan Generator Set for RV

HDKAH (Spec A-K)

HDKAJ (Spec A-K)

HDKAK (Spec A-K)

HDKAT (Spec A-K)

HDKAU (Spec A-K)

HDKAV (Spec A-K)

Introduction

This parts catalog applies to the standard generator sets listed below. Parts are arranged in groups of related items and each illustrated part is defined by a reference number corresponding to the same reference number in the parts list. Parts illustrations are typical. Using the model and specification number from your generator set nameplate, select parts that apply to your set. Unless otherwise mentioned in the description or page heading, parts are interchangeable between models. Throughout this catalog right and left sides are determined by facing the engine end (front) of the set.

Generator Set Data Table					
Model Identification	Rating	Wiring Diagram AC/DC	Voltage	Hertz	Phase
6HDKAH*/	6,000 Watts	611-1236	120	60	1
7.5HDKAJ/*	7,500 Watts	611-1236	120	60	1
8.0HDKAK/*	8,000 Watts	611-1236	120	60	1
6HDKAV/*	6,000 Watts	611-1236	120	60	1
7.5HDKAT/*	7,500 Watts	611-1236	120	60	1
8.0HDKAU/*	8,000 Watts	611-1236	120	60	1

* – The specification number denotes customer requested options or deviations from a standard (1A, 1B, etc.) model. The specification letter advances (A, to B, to C, etc.) with major manufacturing changes.

THIS PAGE IS INTENDED TO BE BLANK

Index

A

Arm, Rocker, **24 , 25**
Armature, Starter, **51**
Assy Cover, Lifting Eye Access, **49**
Assy Door, Access, **49**
Assy Panel, Cap, **49**
Assy Panel, Curb, **49**
Assy Panel, Engine, **49**
Assy Panel, Rail, **49**
Assy Panel, Top, **49**

B

Baffle, Inlet, **33**
Ball, Crankshaft, **11**
Ball, Injection Pump Gear, **17 , 19**
Ball, Valve Seat, **30**
Base, Governor, **26**
Base, Mounting, **45**
Bearing, Carrier Ball, **26**
Bearing, Crankshaft Thrust, **11**
Bearing, Fuel Camshaft, **17 , 19**
Bearing, Starter, **51**
Bearing, Water Pump Ball, **31**
Belt, Water Pump, **39**
Block, AC Terminal, **54**
Block, Battery Harness Terminal, **55**
Block, Cylinder, **9**
Block, Exhaust Fiberglass, **43**
Board, Control, **52**
Bracket, Air Cleaner, **61**
Bracket, Fuel Filter, **32**
Bracket, Inverter, **52**
Bracket, Rocker Arm, **24 , 25**
Bracket, Voltage Regulator, **45**
Breaker, Circuit, **54**
Bushing, Connecting Rod, **11**
Bushing, Crankshaft, **11**
Bushing, Idle Gear, **12**

C

Camshaft, **12**
Camshaft, Fuel, **17 , 19**

Cap, Coolant Drain, **35**
Cap, Coolant Fill, **35**
Cap, Coolant Recovery Tank, **35**
Cap, Cylinder Block Sealing, **9**
Cap, Cylinder Head Sealing, **20**
Cap, Oil Fill, **28**
Cap, Speed Control, **15 , 16**
Cap, Valve, **24 , 25**
Carrier, **26**
Case, Governor Ball, **17 , 19**
Clamp, Hose Bracket, **35**
Clamp, Isolator, **43**
Clamp, Loop, **52**
Clamp, Loop (1.44"), **37**
Clamp, Loop (1"), **36**
Clamp, Loop (3/4"), **33**
Clip, Loop, **52**
Clutch, Starter, **51**
Cock, Oil Drain, **9**
Coil, Governor, **26**
Collar, Crankshaft, **11**
Collet, Valve Spring, **24 , 25**
Components, Injection Nozzle, **23**
Components, Injection Pump, **18**
Components, Starter, **51**
Components, Water Pump, **31**
Control, Speed, **15 , 16**
Cord, Glow Plug, **21 , 22**
Core, AC Harness Ferrite, **54**
Core, Battery Harness Ferrite, **55**
Core, Engine Harness Ferrite, **53**
Cover, AC Access, **47 , 49**
Cover, Air Cleaner (Intake), **33**
Cover, Air Cleaner Element, **33**
Cover, Bearing Plate, **13**
Cover, Breather Element, **28**
Cover, Fuel Camshaft, **9**
Cover, Gearcase Hole, **30**
Cover, Governor, **26**
Cover, Hole, **17 , 19**
Cover, Lifting Eye Access, **47**
Cover, Main Bearing, **13**
Cover, Radiator Fill Access, **47 , 49**

Index

Cover, Valve, **28 , 29**
Cover, Water Temperature Thermostat, **27**
Crankshaft, **11**

D

Door, Maintenance, **45**

E

Edgeing, Trim, **49**
Elbow, Breather, **28**
Elbow, Bulkhead, **32**
Elbow, Exhaust, **43**
Element, Breather, **28**
Element, Intake Air Cleaner, **33**
Engine, Replacement, **9**
Eye, Lifting, **20**

F

Fan, Generator, **50**
Filter, Fuel, **32**
Filter, Oil, **30**
Fitting, Bulkhead, **32**
Fitting, Coolant "T" Hose, **35**
Flange, Component Water Pump, **31**
Flange, Injection Pump Plunger Sleeve, **18**
Flange, Outlet Water Pump, **27**
Frame, Starter, **51**
Fuse, **53**

G

Gasket, Bearing Plate Cover, **13**
Gasket, Cylinder Head, **20**
Gasket, Delivery Valve, **18**
Gasket, Exhaust Manifold, **43**
Gasket, Gearcase, **30**
Gasket, Gearcase Hole Cover, **30**
Gasket, Governor Base, **26**
Gasket, Hole Cover, **17 , 19**
Gasket, Injection Pump, **18**
Gasket, Injector Nozzle, **21 , 22**

Gasket, Inlet Manifold, **40 , 41**
Gasket, Muffler, **43**
Gasket, Oil Filter Flange, **30**
Gasket, Oil Pan, **37 , 38**
Gasket, Oil Pump, **9**
Gasket, Speed Control, **15 , 16**
Gasket, Valve Cover, **28**
Gasket, Water Flange, **27**
Gasket, Water Pump, **31**
Gasket, Water Temperature Thermostat, **27**
Gauge, Oil Pressure (Remote Panel), **60**
Gauge, Water Temperature (Remote Panel), **60**
Gear, Camshaft, **12**
Gear, Crankshaft, **11**
Gear, Idle, **12**
Gear, Injection Pump, **17 , 19**
Gear, Oil Pump Drive, **9**
Gearcase, **30**
Generator, **50**
Governor, **26**
Grommet, Engine Harness, **53**
Grommet, Remote Air Cleaner Kit, **61**
Guard, Circuit Breaker, **47 , 49**
Guard, Fan, **45**
Guide, Valve, **20**

H

Harness, AC, **54**
Harness, Battery, **55**
Harness, Engine, **53**
Harness, Extension, **56**
Harness, Fuel Pump, **61**
Harness, Pigtail, **56**
Harness, Remote Panel (Gauges), **60**
Harness, Remote Panel (On/Off Switch), **57**
Harness, Remote Panel (Switch/Hourmeter), **58**
Harness, Remote Panel (Switch/Voltmeter), **59**
Head, Cylinder, **20**
Hinge, Maintenance Door, **45**
Holder Assy, Nozzle, **23**
Holder, Delivery Valve, **18**
Holder, Fuse, **53**

Index

Holder, Main Bearing, **13**
Holder, Nozzle, **21 , 22**
Hose, Air Bleed, **35**
Hose, Air Cleaner, **61**
Hose, Breather, **28**
Hose, Coolant Fill Neck, **35**
Hose, Intake, **33**
Hose, Oil Fill, **37**
Hose, Overflow, **35**
Hose, Radiator, **35**
Hourmeter, **47 , 49**
Hourmeter (Remote Gauge Panel), **60**
Hourmeter (Remote Switch Panel), **58**
Housing (HDKAJ and HDKAK), **47**
Housing (HDKAT), **49**
Housing, Air Cleaner, **33**
Housing, Flywheel, **50**
Housing, Starter, **51**

I

Impeller, Water Pump, **31**
Indicator, Oil Level, **37**
Insulation, Access Cover, **47**
Insulation, Cap, **47**
Insulation, Door Panel, **49**
Insulation, Engine Panel, **47**
Insulation, Exhaust Baffle, **36**
Insulation, Housing, **47**
Insulation, Panel Curb, **49**
Insulation, Panel Rail, **47**
Insulation, Top Panel, **47**
Insulator, Terminal, **53**
Intake, Air, **33**
Inverter, **52**
Isolator, Muffler, **43**
Isolator, Vibration, **45**

J

Joint, Injection Pump Eye, **18**

K

Key, Camshaft Feather, **12**
Key, Crankshaft Feather, **11**
Key, Cylinder Block Feather, **9**
Key, Fuel Camshaft Feather, **17 , 19**
Kit, Air Cleaner, **33**
Kit, Aux Commercial Fuel Pump, **61**
Kit, Commercial Remote Air Cleaner, **61**
Kit, Housing Insulation, **47**
Kit, Remote Panel (Gauges), **60**
Kit, Remote Panel (On/Off Switch), **57**
Kit, Remote Panel (Switch/Hourmeter), **58**
Kit, Remote Panel (Switch/Voltmeter), **59**
Kit, Starter Brush, **51**

L

Labels, **61**
Latch, Lift and Turn, **49**
Latch, Service Panel, **45**
Lever, Fork, **14**
Line, Fuel, **32**

M

Manifold, Exhaust, **43**
Manifold, Inlet, **40 , 41**
Meter, Voltage (Remote Panel), **59**
Mount, Inverter, **52**
Mount, Radiator, **36**
Muffler, Exhaust, **43**

N

Neck, Coolant Fill, **35**
Nipple, Gearcase Hex Pipe, **30**
Nozzle, Injection, **21 , 22**
Nozzle, Injection Component, **23**

Index

O

O'Ring, Coolant Tank Cap, **35**
O'Ring, Cylinder Block, **9**
O'Ring, Cylinder Head, **20**
O'Ring, Gearcase, **30**
O'Ring, Governor Rotor, **26**
O'Ring, Injection Pump, **18**
O'Ring, Oil Level Indicator, **37**
O'Ring, Oil Pickup Tube, **37 , 38**
O'Ring, Oil Slinger, **11**
O'Ring, Valve Cover Cap Nut, **28**
Outlet, Water, **27**

P

Pan, Oil, **37 , 38**
Panel Assy, Printed, **60**
Panel, Cap, **47**
Panel, Printed, **59**
Panel, Remote Gauge, **60**
Panel, Remote Switch, **57**
Panel, Remote Switch/Hourmeter, **58**
Panel, Remote Switch/Voltmeter, **59**
Panel, w /Decal, **60**
PCB Assy, Filter DC, **55**
Pin, Cylinder Block Hollow, **9**
Pin, Cylinder Block Straight, **9**
Pin, Gearcase Spring, **30**
Pin, Governor Spring, **14**
Pin, Injection Pump, **18**
Pin, Injection Pump Joint, **18**
Pin, Piston, **11**
Pipe, Exhaust Flex, **43**
Pipe, Injection, **21 , 22**
Pipe, Overflow, **21 , 22**
Pipe, Water Pump Return, **31**
Pipe, Water Return, **27**
Piston, **11**
Plate, Breather Element, **28**
Plate, Camshaft Retaining, **12**
Plate, Fuel Camshaft Retaining, **17 , 19**
Plate, Injection Pump, **18**
Plug, Cylinder Block, **9**

Plug, Cylinder Head Pipe, **20**
Plug, Gearcase Pipe, **30**
Plug, Glow, **21**
Plug, Oil Drain, **37 , 38**
Plunger, Injection Pump, **18**
Pulley, Drive, **39**
Pulley, Fan, **39**
Pump, Aux Fuel, **61**
Pump, Fuel, **32**
Pump, Injection, **17 , 19**
Pump, Injection Component, **18**
Pump, Oil, **9**
Pump, Water, **31**

R

Rack, Injection Pump Control, **18**
Radiator, **36**
Regulator, **45**
Resonator, Intake, **33**
Retainer, Valve Spring, **24 , 25**
Ring, Idle Gear Retaining, **12**
Ring, Piston Pin Retaining, **11**
Rocker, Switch, **49**
Rod, Camshaft Push, **12**
Rod, Connecting, **11**
Rod, Injection Nozzle Push, **23**
Rotor, Generator, **50**
Rotor, Governor, **26**

S

Seal, Air Cleaner Spacer, **33**
Seal, Bearing Plate Cover Oil, **13**
Seal, Coolant Hose, **35**
Seal, Exhaust Pipe, **43**
Seal, Fuel Pump, **32**
Seal, Gearcase Oil, **30**
Seal, Housing, **33**
Seal, Injection Nozzle Heat, **21 , 22**
Seal, Maintenance Door, **45**
Seal, Oil Drain, **37**
Seal, Oil Fill Cap, **28**

Index

Seal, Radiator Spacer, **36**
Seal, Valve Stem, **24 , 25**
Seal, Water Pump, **31**
Seat, Injection Pump Spring, **18**
Seat, Valve, **30**
Sender, Water Temperature, **27**
Set, Crankshaft Bearing, **11**
Set, Piston Ring, **11**
Shaft, Governor, **14**
Shaft, Idle Gear, **12**
Shaft, Rocker Arm, **24 , 25**
Shield, Breather Oil, **28 , 29**
Shim, Injection Pump, **17 , 19**
Shim, Pump, **18**
Sleeve, Air Intake, **33**
Sleeve, Crankshaft, **11**
Sleeve, Fuel Line, **32**
Sleeve, Governor, **17 , 19**
Sleeve, Injection Pump Control, **18**
Slinger, Oil, **11**
Spacer, Idle Gear, **12**
Spacer, Injection Nozzle, **23**
Spring, Delivery Valve, **18**
Spring, Fork Lever Governor, **14**
Spring, Governor, **26**
Spring, Injection Nozzle, **23**
Spring, Injection Pump Plunger, **18**
Spring, Rocker Arm, **24 , 25**
Spring, Valve, **24 , 25**
Spring, Valve Seat, **30**
Starter Components, **51**
Starter Mounting, **50**
Stator, Generator, **50**
Strap, Bond, **45**

Switch, Oil Pressure, **9**
Switch, Rocker, **47**
Switch, Start/Stop (Remote Gauge Panel), **60**
Switch, Start/Stop (Remote Hourmeter Panel), **58**
Switch, Start/Stop (Remote Panel), **57**
Switch, Start/Stop (Remote Voltmeter Panel), **59**
Switch, Starter, **51**
System, Cooling, **35**
System, Exhaust, **43**
System, Fuel, **32**

T

Tank, Coolant Recovery, **35**
Tappet, Camshaft, **12**
Tappet, Injection Pump, **18**
Thermostat, Water Temperature, **27**
Transformer, **54**
Transformer, Battery Charge, **45**
Trough, Oil Drain, **32**
Tube, Adapter, **61**
Tube, Exhaust, **43**
Tube, Oil Pickup, **37 , 38**

V

Valve, Delivery, **18**
Valve, Exhaust, **24 , 25**
Valve, Intake, **24 , 25**

W

Wall, Back, **36**
Wire, Retainer, **18**

THIS PAGE IS INTENDED TO BE BLANK

Cylinder Block

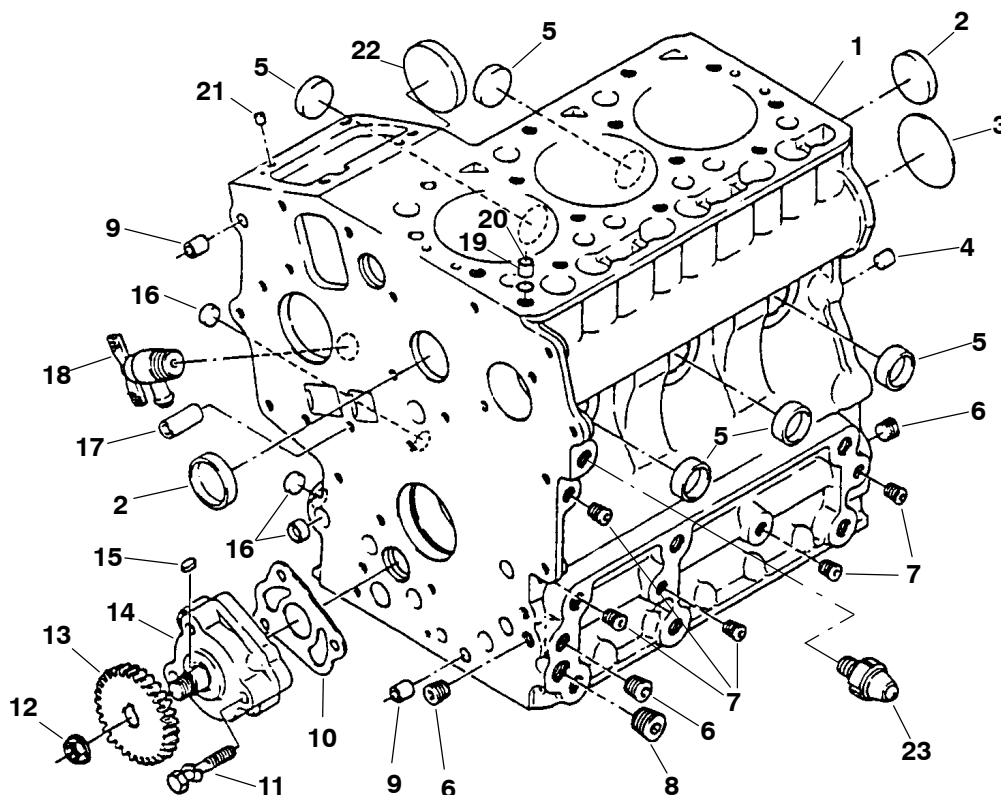

REF NO.	PART NO.	QTY USED	PART DESCRIPTION	REF NO.	PART NO.	QTY USED	PART DESCRIPTION
			Engine, Replacement HDKAH, HDKAJ, HDKAK	10	185-5413	1	*Gasket, Oil Pump
	100-3707	1	Spec A-H	11	185-5491	3	*Screw, Hex Head Cap
	100-3957	1	Begin Spec J	12	185-5416	1	*Nut, Flange Hex
	100-3707	1	Spec A-E	13	185-5414	1	*Gear, Oil Pump Drive
	100-3957	1	Begin Spec F	14		1	*Pump, Oil
1			Block Assy, Cylinder (Includes Parts Marked *) HDKAH, HDKAJ, HDKAK		185-5412	1	HDKAH, HDKAJ, HDKAK Spec A-H
	185-6704	1	Spec A-H		181-9165	1	Begin Spec J HDKAT, HDKAU, HDKAU
	181-9183	1	Begin Spec J		185-5412	1	Spec A-F
	185-6704	1	Spec A-E	15	185-5415	1	*Key, Feather
	181-9183	1	Begin Spec F	16	185-5482	3	*Cap, Sealing
2	185-5484	2	*Cap, Sealing	17	185-5488	2	*Pin, Hollow
3	185-5485	1	*Plug	18	185-5490	1	*Cock, Drain
4	185-5487	2	*Pin, Straight	19	185-2095	1	*O'Ring
5	185-5483	5	*Cap, Sealing	20	185-2094	1	*Pin, Hollow
6	185-2233	3	*Plug, Pipe	21	185-5486	2	*Pin, Straight
7	185-2412	5	*Plug, Pipe	22	185-5489	1	*Cover, Fuel Camshaft
8	185-2234	1	*Plug, Pipe	23	185-5492	1	Switch, Oil Pressure (S15)*
9	185-2115	2	*Pin, Hollow				

* - Parts Included in Cylinder Block Assy.

Crankshaft

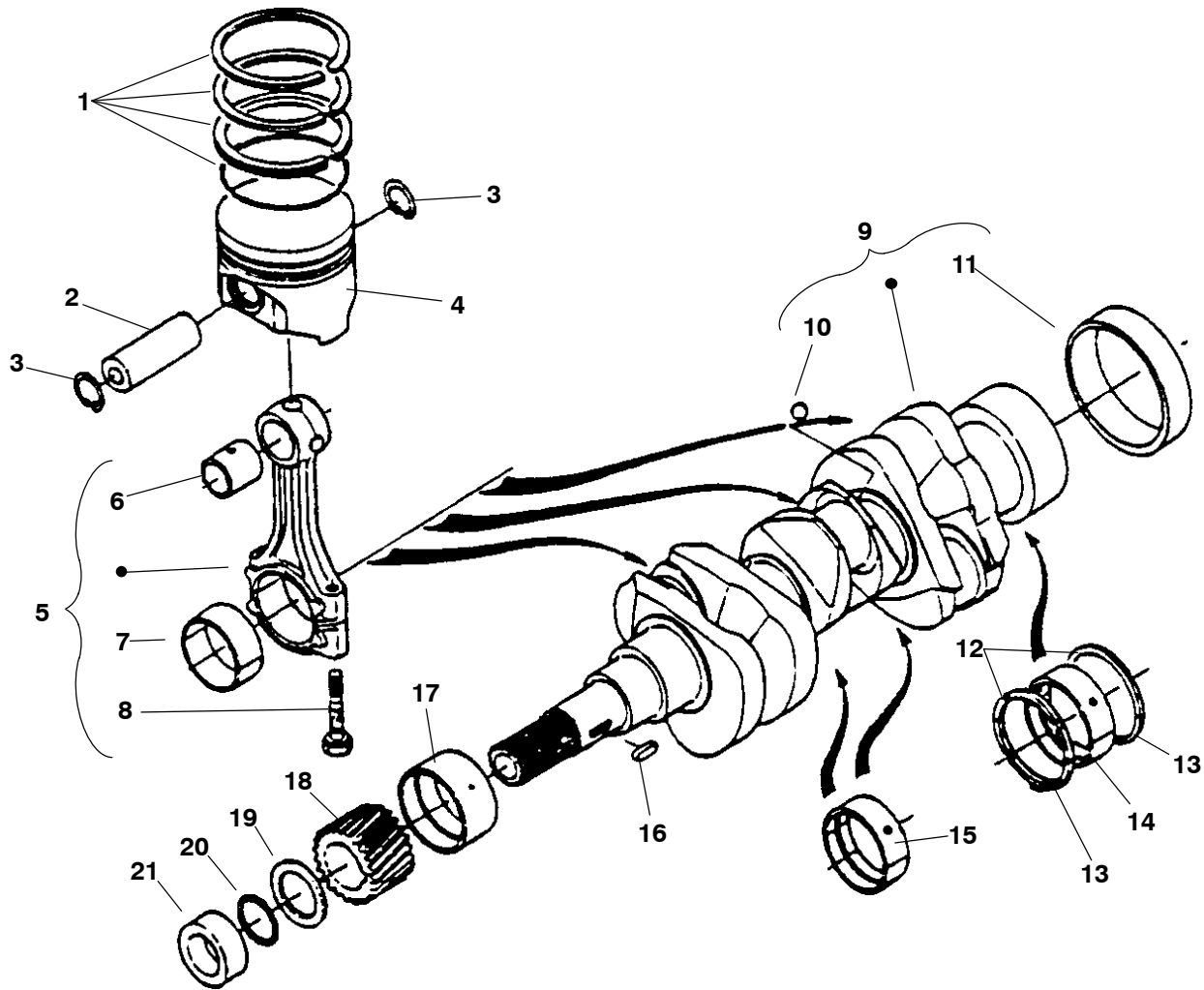

Crankshaft

REF NO.	PART NO.	QTY USED	PART DESCRIPTION	REF NO.	PART NO.	QTY USED	PART DESCRIPTION
1			Set, Piston Ring HDKAH, HDKAJ, HDKAK	8	185-5570	6	Bolt, Connecting Rod
			Spec A-H	9			Crankshaft (Includes Ball and Sleeve)
	185-7076	3	Standard				HDKAH, HDKAJ, HDKAK
	185-5351	3	+ 0.25 mm		185-6705	1	Spec A-H
			Begin Spec J		185-7415	1	Begin Spec J
	185-7076	3	Standard				HDKAT, HDKAU ,HDKAV
	185-7386	3	+ 0.25 mm		185-6705	1	Spec A-E
			HDKAT, HDKAU, HDKAV		185-7415	1	Begin Spec F
			Spec A-E	10	185-5575	3	Ball
	185-7076	3	Standard	11	185-2033	1	Sleeve
	185-5351	3	+ 0.25 mm	12			Bearing, Thrust
			Begin Spec F		185-2022	2	Standard
	185-7076	3	Standard		185-2028	2	+ 0.20 mm
	185-7386	3	+ 0.25 mm		185-2029	2	+ 0.40 mm
2			Pin, Piston	13			Bearing, Thrust
			HDKAH, HDKAJ, HDKAK		185-2023	2	Standard
	185-5568	3	Spec A-H		185-2030	2	+ 0.20 mm
	112-0304	3	Begin Spec J		185-2031	2	+ 0.40 mm
			HDKAT, HDKAU, HDKAV	14			Set, Bearing
	185-5568	3	Spec A-E		185-5580	2	Standard
	112-0304	3	Begin Spec F		185-5356	2	- 0.20 mm
3	185-2016	6	Ring, Retaining		185-5357	2	- 0.40 mm
4			Piston	15			Set, Bearing
	185-5566	3	Standard		185-5581	2	Standard
	185-5350	3	+ 0.25 mm		185-5360	2	- 0.20 mm
5			Rod, Connecting (Includes Bushings and Bolt)		185-5361	2	- 0.40 mm
			HDKAH, HDKAJ, HDKAK	16	185-2353	1	Key, Feather
			Spec A-H	17			Bushing, Crankshaft
	185-5569	3	Begin Spec J		185-5577	1	Standard
	181-9162	3	HDKAT, HDKAU ,HDKAV		185-5578	1	- 0.20 mm
			Spec A-E		185-5579	1	- 0.40 mm
	185-5569	3	Begin Spec F	18	185-5576	1	Gear, Crankshaft
	181-9162	3		19	185-5583	1	Slinger, Oil
6			Bushing, Connecting Rod	20			O'Ring
			HDKAH, HDKAJ, HDKAK				HDKAH, HDKAJ, HDKAK
	185-5358	3	Spec A-H		185-5584	1	Spec A-H
	508-1255	3	Begin Spec J		509-0380	1	Begin Spec J
			HDKAT, HDKAU ,HDKAV				HDKAT, HDKAU ,HDKAV
	185-5358	3	Spec A-E		185-5584	1	Spec A-E
	508-1255	3	Begin Spec F		509-0380	1	Begin Spec F
7			Bushing, Connecting Rod	21	185-7407	1	Collar
	185-5571	3	Standard				
	185-5572	3	- 0.20 mm				
	185-5573	3	- 0.40 mm				

Camshaft

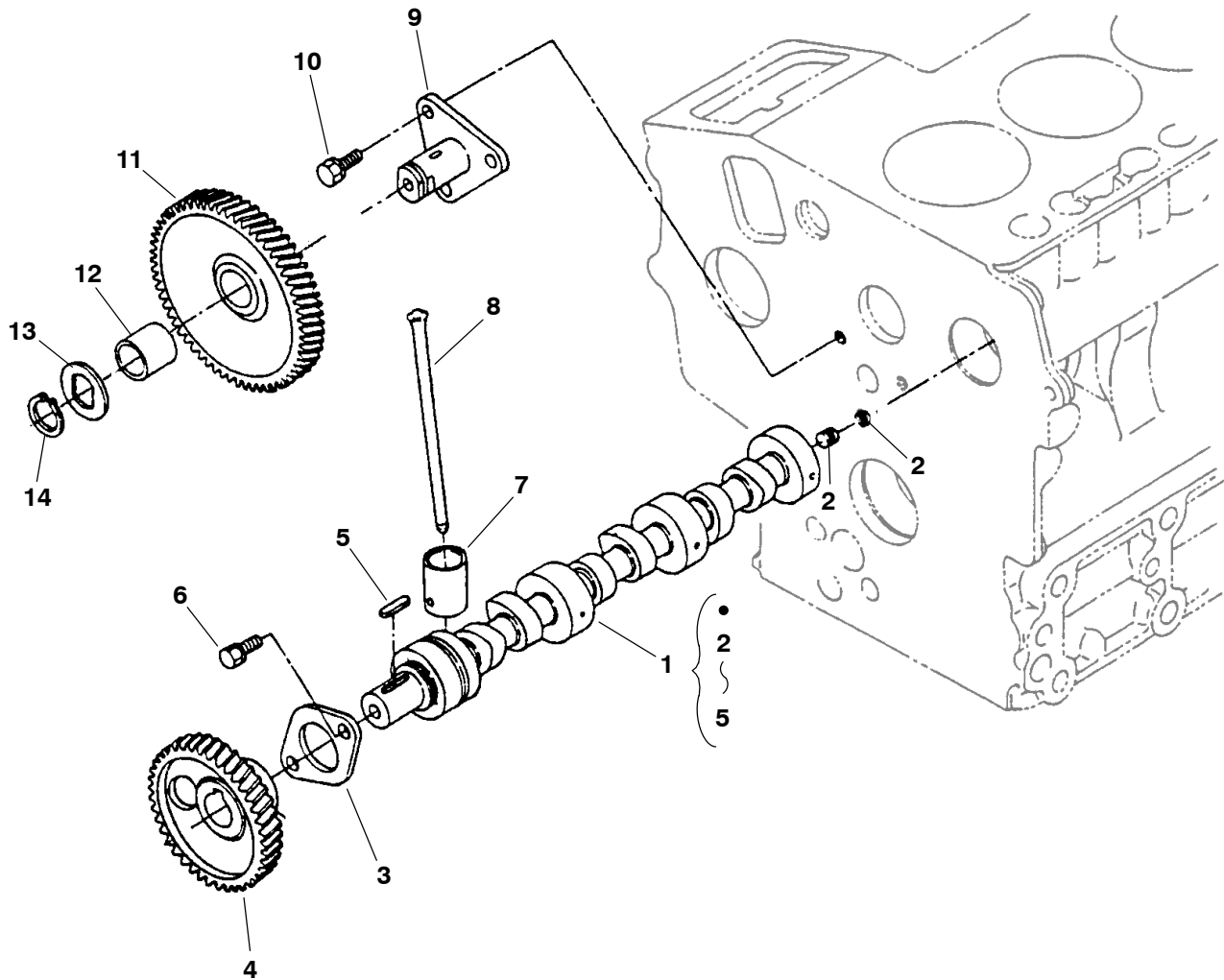

REF NO.	PART NO.	QTY USED	PART DESCRIPTION	REF NO.	PART NO.	QTY USED	PART DESCRIPTION
1	185-7074	1	Camshaft Assy (Includes Parts Marked *)	9	185-5565	1	Shaft, Idle Gear HDKAH, HDKAJ, HDKAK
2			*Screw/Bearing HDKAH, HDKAJ, HDKAK	185-5554	1	1	Spec A-H
	185-5558	1	Spec A-H Set Screw	181-9159	1	1	Begin Spec J HDKAT, HDKAU, HDKAV
	185-5924	1	Begin Spec J Ball Bearing HDKAT, HDKAU, HDKAV	185-5554	1	1	Spec A-E
	185-5558	1	Spec A-E Set Screw	181-9159	1	1	Begin Spec F
	185-5924	1	Begin Spec F Ball Bearing	10	185-2387	3	Screw, Hex Washer Head Cap W/Lock (M6 x 14mm)
3	185-5561	1	*Plate, Retaining	11	185-5562	1	Gear, Idle (Includes Bushing)
4	185-7075	1	*Gear, Camshaft	12	185-7385	1	Bushing, Idle Gear
5	185-5560	1	*Key, Feather	13	185-5563	1	Spacer
6	185-2380	2	Screw, Hex Washer Head W/Lock Cap (M6 x 12mm)	14	185-5564	1	Ring, Retaining
7			Tapet				
8	185-5555	6	Rod, Push				

* - Parts Included in Camshaft Assy.

Main Bearing Holders

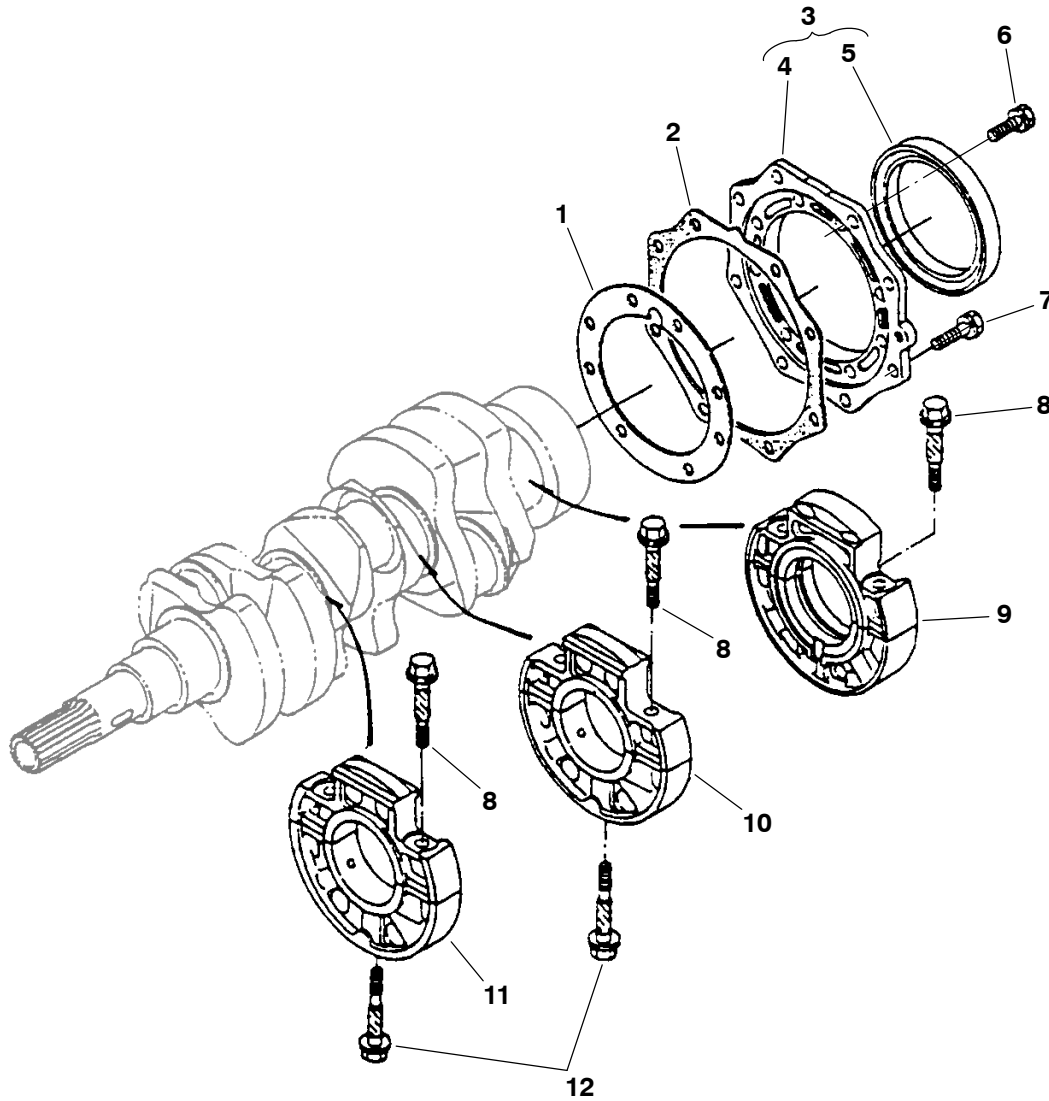

REF NO.	PART NO.	QTY USED	PART DESCRIPTION	REF NO.	PART NO.	QTY USED	PART DESCRIPTION
1	185-5438	1	Gasket	7	185-2559	8	Screw, Hex Head Cap
2	185-7383	1	Gasket	8	185-5515	6	Screw, Hex Head Cap
3	185-7073	1	Cover Assy, Main Bearing Case (Includes Cover and Seal)	9	185-7072	1	Holder, Main Rear Bearing
4	185-5516	1	Cover, Bearing Plate	10	185-5808	1	Holder, Main Center Bearing
5	185-5437	1	Seal, Oil	11	185-5517	1	Holder, Main Front Bearing
6	185-2390	8	Screw, Hex Head W/Lock Cap Washer (M6 x 20mm)	12	185-5519	2	Bolt, Bearing Case

Fork Lever

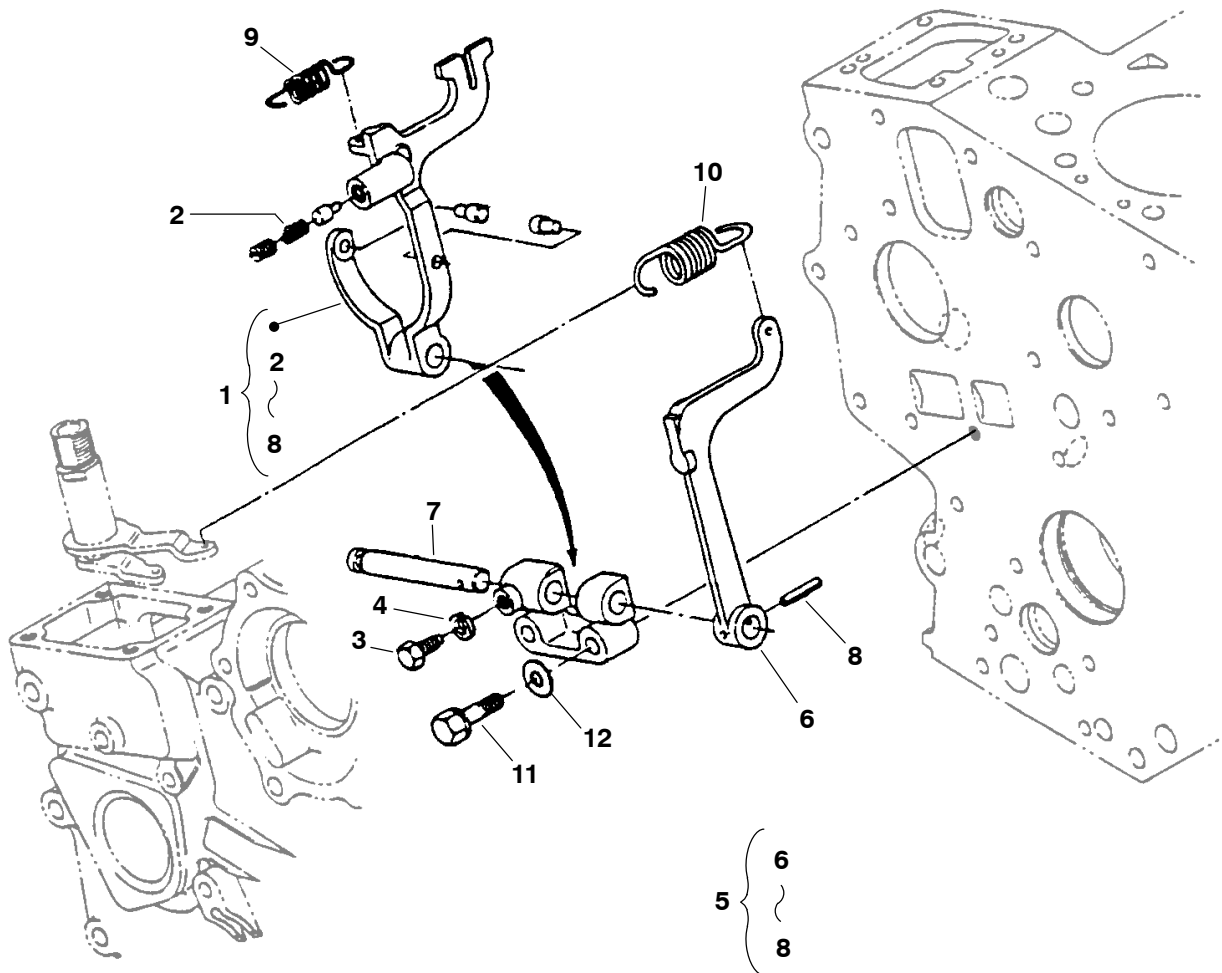

REF NO.	PART NO.	QTY USED	PART DESCRIPTION	REF NO.	PART NO.	QTY USED	PART DESCRIPTION
1	185-6945	1	Lever Assy, Fork (Includes Parts Marked *)	8	185-5696	1	*Pin, Spring
2	181-9203	1	*Spring	9	181-9169	1	Spring, Start
3	185-2173	1	*Screw, Hex Head Cap	10	184-0054	1	Spring, Governor
4	185-6999	1	*Washer, Spring Lock	11	185-2393	2	Screw, Hex Head Cap (M6 x 35mm)
5	185-5701	1	*Lever Assy, Outer Fork (Includes Lever, Shaft and Pin)	12	185-5966	2	Washer, Plain
6	185-5702	1	*Lever, Outer Fork				
7	185-5703	1	*Shaft				

* - Parts Included in Fork Lever Assy.

Speed Control
HDKAH, HDKAJ, HDKAK Spec A-H
HDKAT, HDKAU, HDKAV Spec A-E

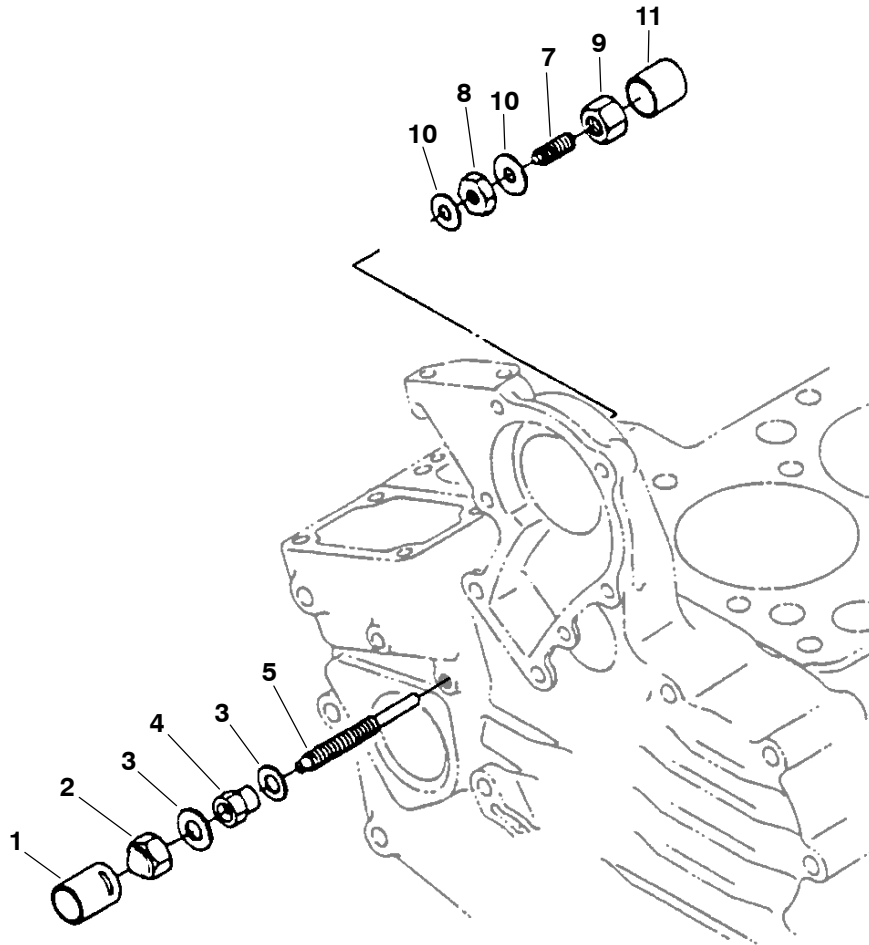

REF NO.	PART NO.	QTY USED	PART DESCRIPTION	REF NO.	PART NO.	QTY USED	PART DESCRIPTION
1	185-2283	1	Cap	8	185-2180	1	*Nut, Hex
2	185-5685	1	Nut, Cap	9	185-5681	1	*Nut, Cap
3	185-2284	2	Gasket	10	185-2338	2	*Gasket
4	185-6931	1	Nut, Hex	11	185-5682	1	*Cap
5	185-7078	1	Screw, Adjusting				
6	185-5679	1	Idle Assy., Obsolete				
7	185-5680	1	*Bolt, Adjusting (Includes Nuts)				

* - Parts Included in Idle Assy.

Speed Control
HDKAH, HDKAJ, HDKAK Begin Spec J
HDKAT, HDKAU, HDKAV Begin Spec E

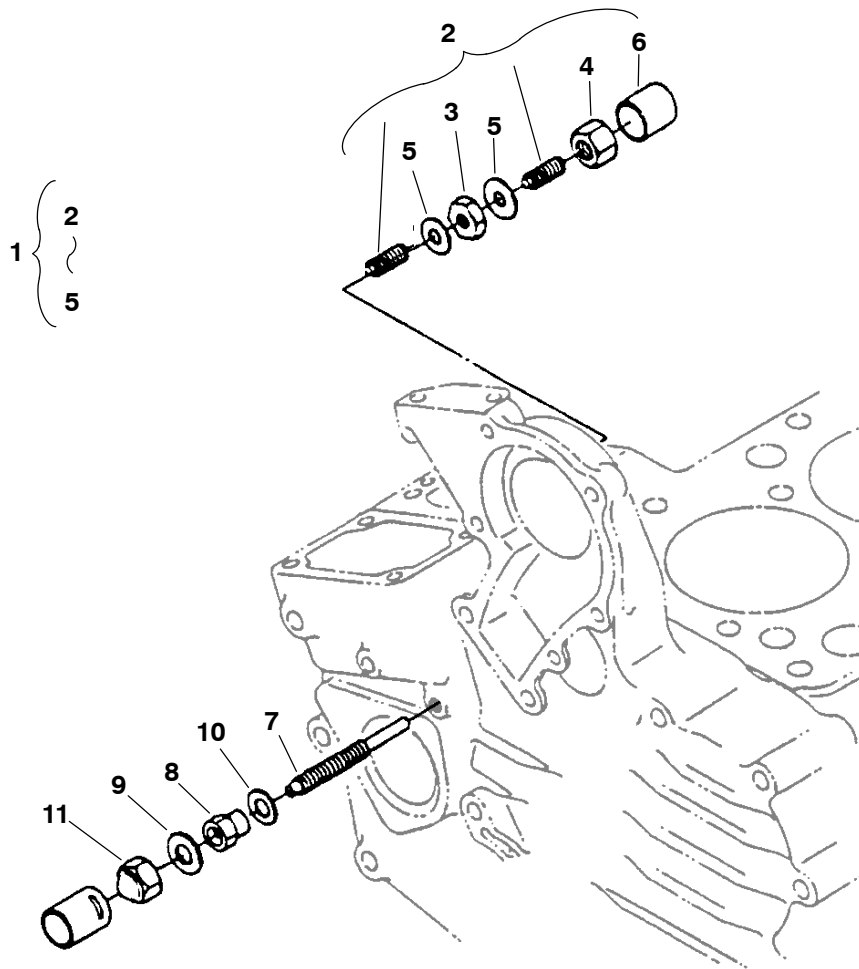

REF NO.	PART NO.	QTY USED	PART DESCRIPTION	REF NO.	PART NO.	QTY USED	PART DESCRIPTION
1	185-5679	1	Assy, Idle Apparatus (Includes Parts Marked *)	7	150-2872	1	Screw, Adjusting
2	185-5680	1	*Bolt, Adjusting (Includes Nuts)	8	185-6931	1	Nut, Hex
3	185-2180	1	*Nut, Hex	9	185-2284	1	Gasket
4	185-5681	1	*Nut, Cap	10	185-2870	1	Gasket
5	185-2338	2	*Gasket	11	185-5685	1	Nut
6	185-5682	1	Cap				

* - Parts Included in Idle Assy.

Injection Pump

HDKAH, HDKAJ, HDKAK Spec A-H
HDKAT, HDKAU, HDKAV Spec A-E

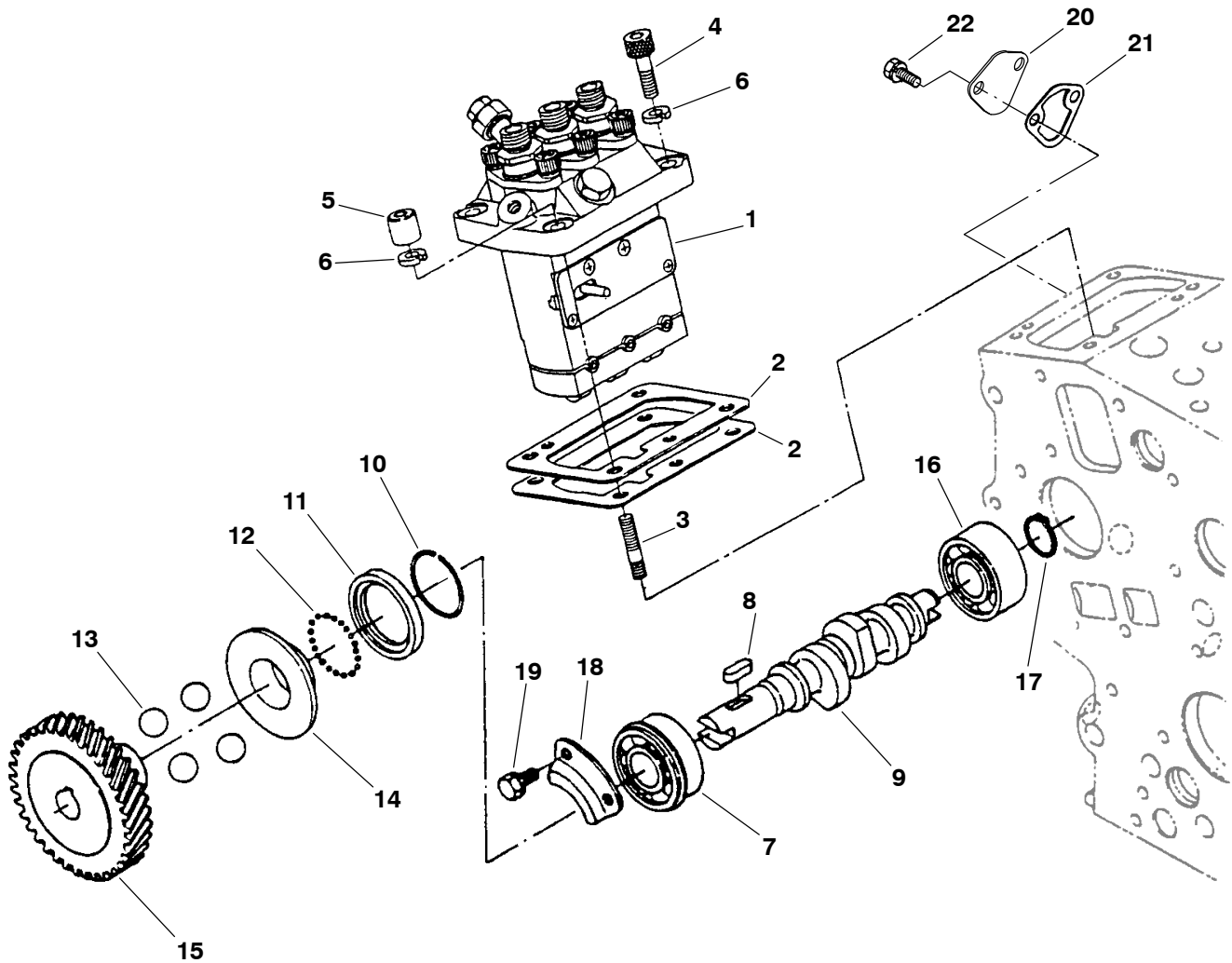

REF NO.	PART NO.	QTY USED	PART DESCRIPTION	REF NO.	PART NO.	QTY USED	PART DESCRIPTION
	185-7077	1	Camshaft Assy, Fuel (Includes Parts Marked *)	12	185-2357	32	*Ball
1	185-6937	1	Pump, Injection	13	185-5633	4	*Ball
2			Shim, Injection Pump	14	185-5631	1	*Sleeve, Governor
	185-6883	1	.20mm	15	185-5630	1	*Gear, Injection Pump
	185-6739	1	.25mm	16	510-0163	1	Bearing
	185-6845	1	.30mm	17	185-5634	1	Circlip
3	185-5624	2	Stud	18	185-5635	1	Plate, Retaining
4	185-5623	2	Screw, Socket Head Cap	19	185-2386	2	Screw, Hex Lock Washer Cap (M6 x 12mm)
5	185-5625	2	Nut, Cap	20	185-5798	1	Cover, Hole
6	185-6759	4	Washer, Spring Lock	21	185-6580	1	Gasket, Hole Cover
7	185-5629	1	*Bearing, Ball	22	185-2389	2	Screw, Hex Head Cap
8	185-2353	1	*Key, Feather				
9	185-6706	1	*Camshaft, Fuel				
10	185-2163	1	*Circlip, Governor Sleeve				
11	185-5632	1	*Case, Governor Ball				

* - Parts Included in Fuel Camshaft Assy.

Injection Pump Components HDKAH, HDKAJ, HDKAK Spec A-H HDKAT, HDKAU, HDKAV Spec A-E

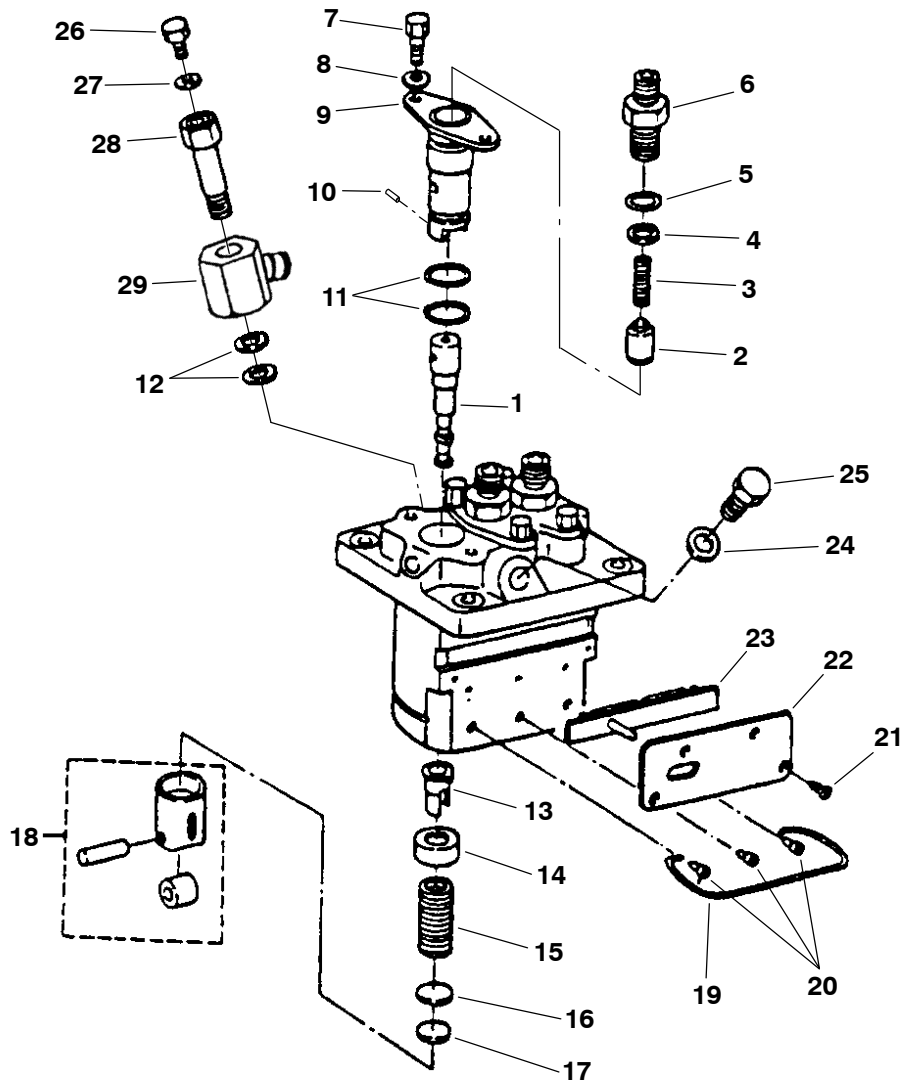

REF NO.	PART NO.	QTY USED	PART DESCRIPTION	REF NO.	PART NO.	QTY USED	PART DESCRIPTION
	185-6937	1	Pump Assy, Injection	15	185-5652	3	Spring, Plunger
1	185-5638	3	Plunger, Injection Pump	16	185-5654	3	Seat, Lower Spring
2	185-5639	3	Valve, Delivery	17	185-5655	3	Shim
3	185-5640	3	Spring, Delivery Valve	18	185-5649	3	Tappet
4	185-5641	3	Gasket, Delivery Valve	19	185-6707	1	Wire, Retainer
5	185-5643	3	O'Ring	20	185-5650	3	Pin
6	185-5642	3	Holder, Delivery Valve	21	185-5658	4	Screw, Machine
7	185-5647	6	Screw, Round Head Machine	22	185-5818	1	Plate
8	185-5648	6	Washer	23	185-5817	1	Rack, Control
9	185-5644	3	Flange, Sleeve	24	185-5820	1	Gasket, Injection Pump
10	185-5645	3	Pin, Joint	25	185-5819	1	Bolt
11	185-5646	6	O'Ring	26	185-5662	1	Screw
12	185-5661	2	O'Ring	27	185-5663	1	Gasket
13	185-5659	3	Sleeve, Control	28	185-5660	1	Screw, Follow
14	185-5653	3	Seat, Upper Spring	29	185-5626	1	Joint, Eye

Injection Pump

HDKAH, HDKAJ, HDKAK Begin Spec J
HDKAT, HDKAU, HDKAV Begin Spec F

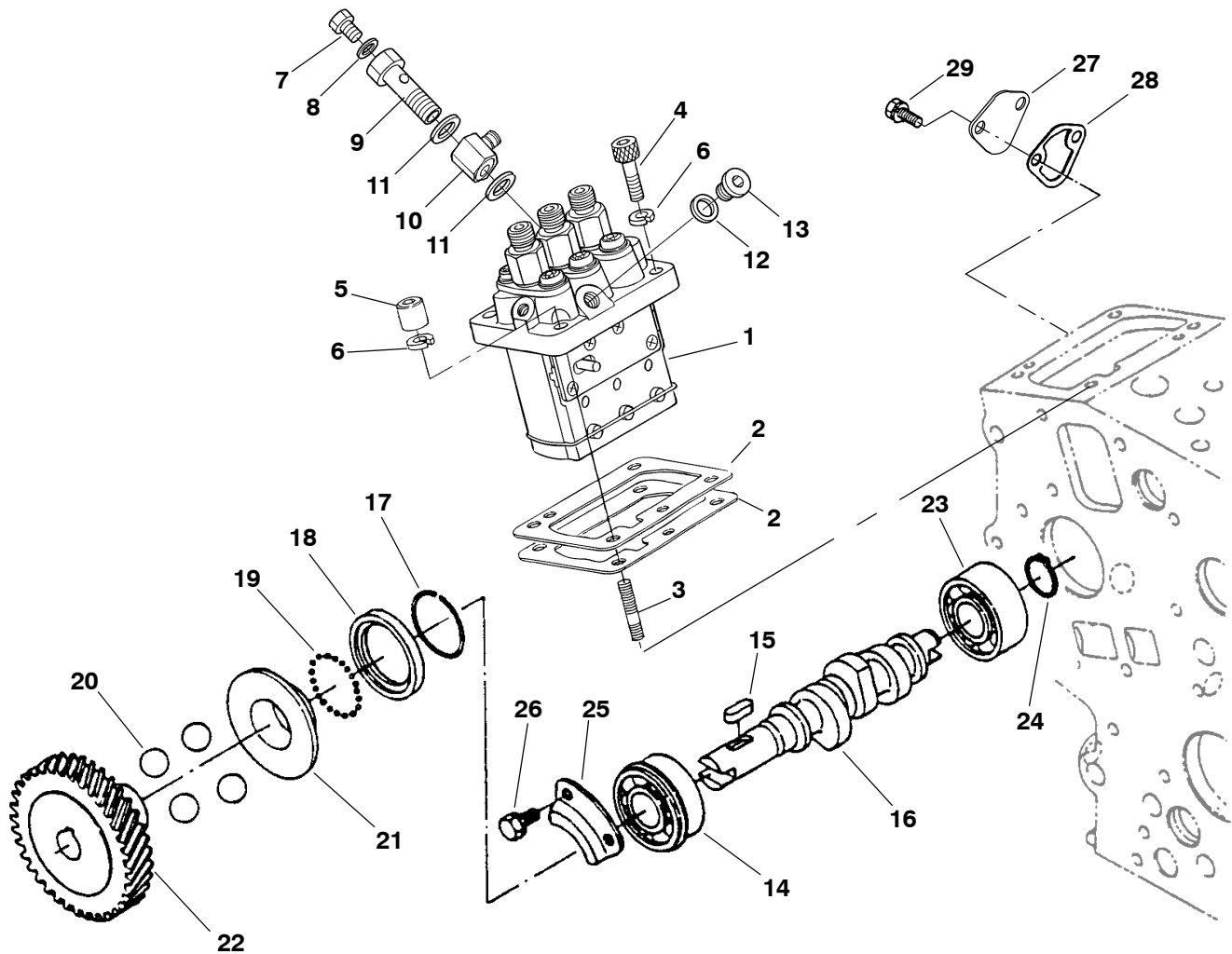

REF NO.	PART NO.	QTY USED	PART DESCRIPTION	REF NO.	PART NO.	QTY USED	PART DESCRIPTION
	181-9201		Camshaft Assy, Fuel (Includes Parts Marked +)	15	185-2353	1	+Key, Feather
1	185-5425	1	Pump, Injection (Includes Parts Marked*)	16	181-9075	1	+Camshaft, Fuel
2			Shim, Injection Pump	17	185-2163	1	+Circlip, Governor Sleeve
	185-6883	1	.20mm	18	185-5632	1	+Case, Governor Ball
	185-6739	1	.25mm	19	185-2357	32	+Ball
	185-6845	1	.30mm	20	185-5633	4	+Ball
3	185-5624	2	Stud	21	185-5631	1	+Sleeve, Governor
4	185-5623	2	Screw, Socket Head Cap	22	185-5630	1	+Gear, Injection Pump
5	185-5625	2	Nut, Cap	23	510-0229	1	Bearing
6	185-6759	4	Washer, Spring Lock	24	185-5634	1	Circlip
7	185-5662	1	*Screw	25	185-5635	1	Plate, Retaining
8	185-5663	1	*Gasket	26	185-2380	2	Screw, Hex Lock Washer Cap (M6 x 12mm)
9	185-5660	1	*Screw, Hollow	27	185-5798	1	Cover, Hole
10	185-5626	1	Joint, Eye	28	185-6919	1	Gasket, Hole Cover
11	185-5661	2	*Gasket	29	185-2389	2	Screw, Hex Head Cap
12	185-5820	1	*Gasket				
13	185-6888	1	*Plug				
14	185-5629	1	+Bearing, Ball				

* - Parts Included in Fuel Camshaft Assy.

Cylinder Head

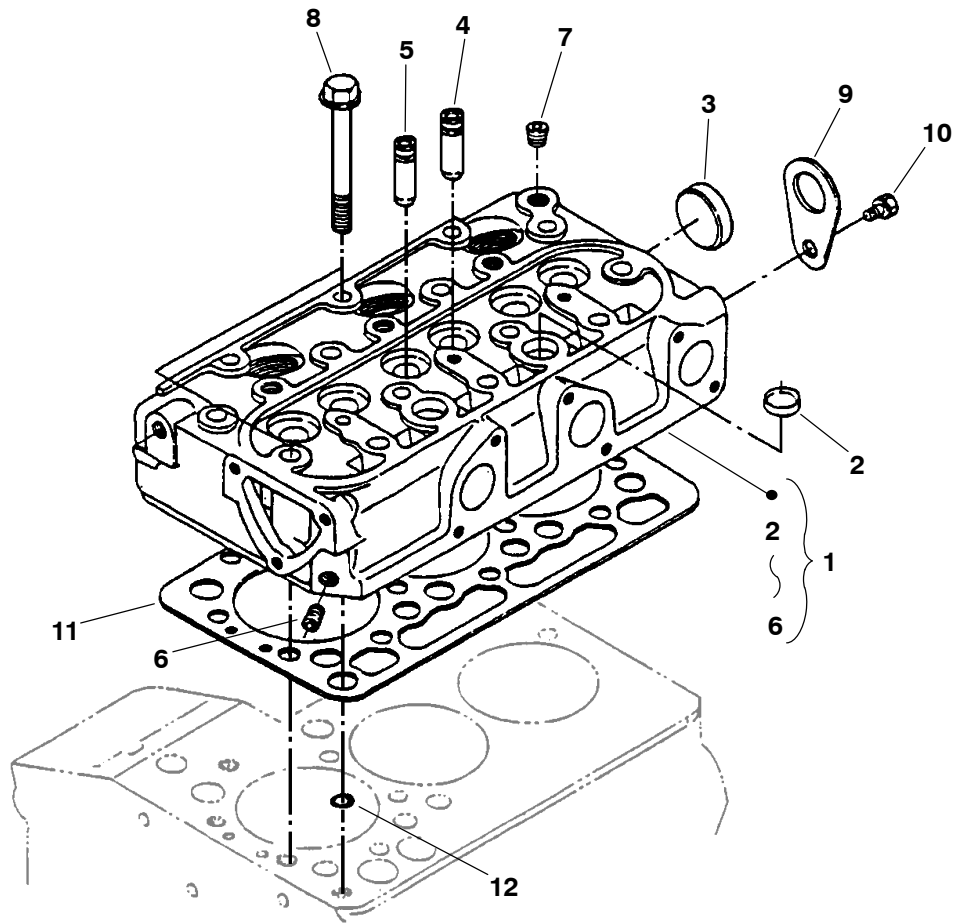

REF NO.	PART NO.	QTY USED	PART DESCRIPTION	REF NO.	PART NO.	QTY USED	PART DESCRIPTION
1			Head Assy, Cylinder (Includes Parts Marked *)	5	185-5500	3	*Guide, Intake Valve
			HDKAH, HDKAJ, HDKAK	6	185-2188	1	*Plug, Pipe
	185-5805	1	Spec A-H	7	185-5502	1	Plug, Pipe
	181-9247	1	Begin Spec J	8	185-5503	14	Bolt, Cylinder Head
			HDKAT, HDKAU, HDKAV	9	185-2414	1	Eye, Lifting
	185-5805	1	Spec A-E	10	185-6762	1	Screw, Hex Head Cap
	181-9247	1	Begin Spec F	11	185-6120	1	Gasket, Cylinder Head
2	185-2413	2	*Cap, Sealing	12	185-2095	1	O'Ring
3	185-2411	1	*Cap, Sealing				
4	185-5501	3	*Guide, Exhaust Valve				

* - Parts Included in Cylinder Head Assy.

Injection Nozzle
HDKAH, HDKAJ, HDKAK Spec A-H
HDKAT, HDKAU, HDKAV Spec A-E

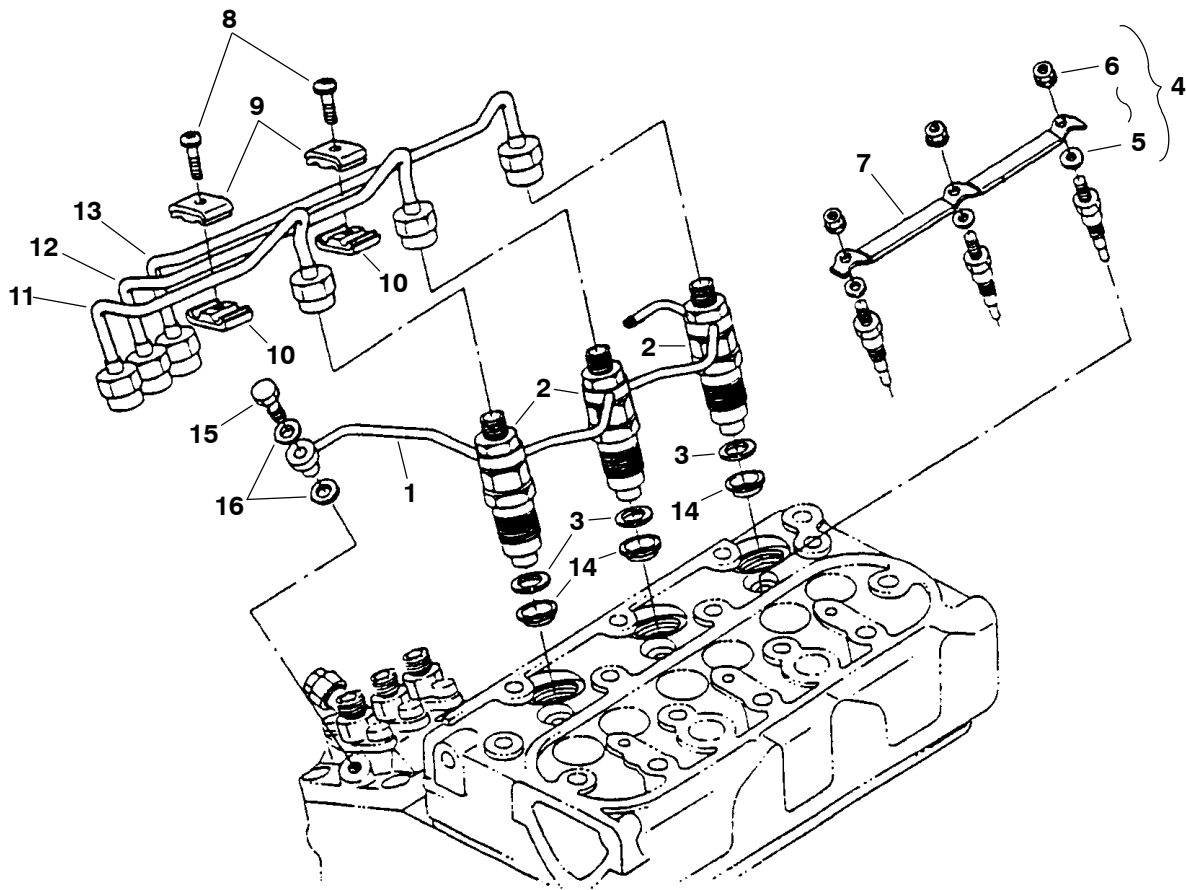

REF NO.	PART NO.	QTY USED	PART DESCRIPTION	REF NO.	PART NO.	QTY USED	PART DESCRIPTION
1	185-6948	1	Pipe, Overflow	9	185-2345	2	Clamp, Top Pipe
2	185-6738	3	Holder, Nozzle	10	185-5612	2	Clamp, Bottom Pipe
3	185-5337	3	Gasket	11	185-7389	1	Pipe, Injection
4	185-5421	3	Plug, Glow (HR5) (Includes Washer and Nut)	12	185-7390	1	Pipe, Injection
5	185-7004	3	Washer, Plain	13	185-7397	1	Pipe, Injection
6	185-5615	3	Nut, Flange	14	185-5985	3	Seal, Heat
7	185-5823	1	Cord, Glow Plug	15	185-7082	1	Screw, Air Bleeder
8	185-2385	2	Screw, Pan Head Machine W/Lock Washer	16	185-2284	2	Packing, O'Ring

Injection Nozzle
HDKAH, HDKAJ, HDKAK Begin Spec J
HDKAT, HDKAU, HDKAV Begin Spec F

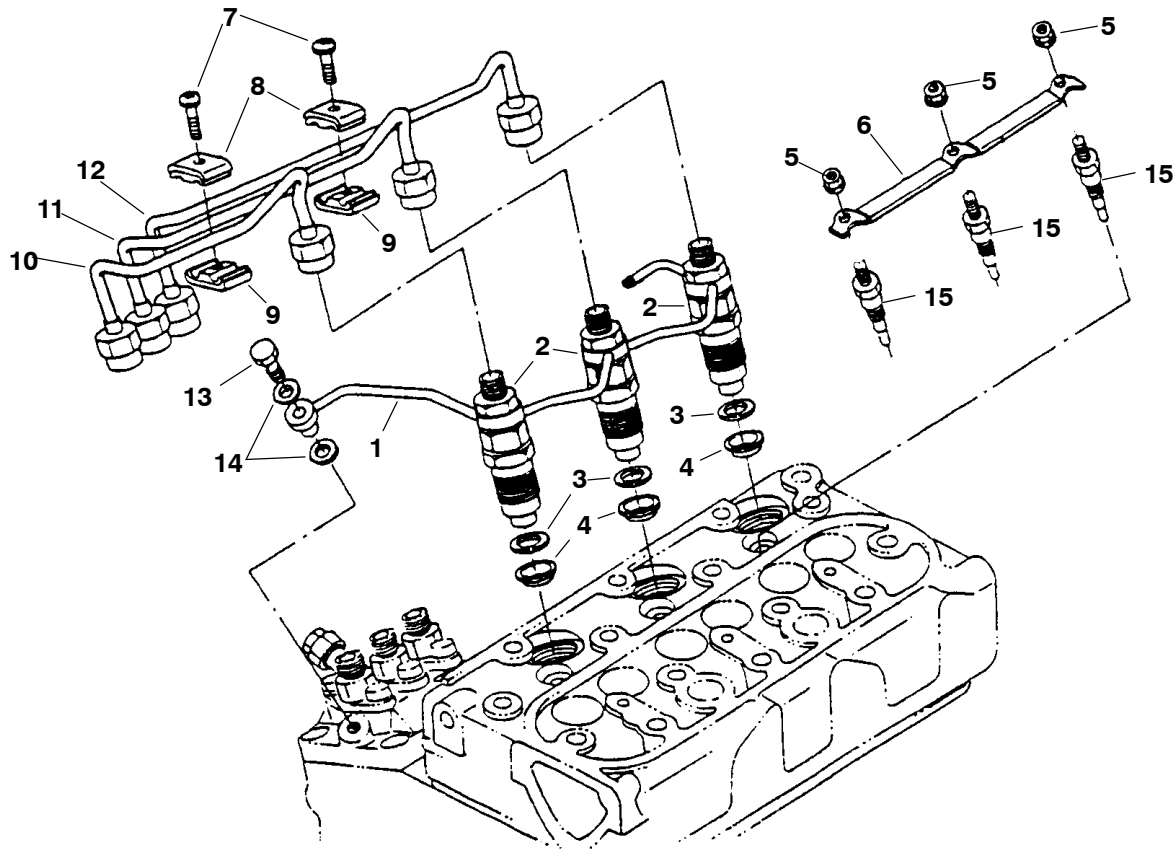

REF NO.	PART NO.	QTY USED	PART DESCRIPTION	REF NO.	PART NO.	QTY USED	PART DESCRIPTION
1	181-9202	1	Pipe, Overflow	8	185-5613	2	Clamp, Top Pipe
2	185-6738	3	Holder, Nozzle	9	185-5612	2	Clamp, Bottom Pipe
3	185-5337	3	Gasket	10	501-0927	1	Pipe, Injection
4	185-5985	3	Seal, Heat	11	181-9168	1	Pipe, Injection
5	185-5615	3	Nut, Flange	12	181-9177	1	Pipe, Injection
6	185-5823	1	Cord, Glow Plug	13	185-7082	1	Screw, Air Bleeder
7	185-2385	2	Screw, Pan Head Machine W/Lock Washer	14	185-2284	2	O'Ring
				15	185-5421	3	Plug, Glow

Injection Nozzle Components

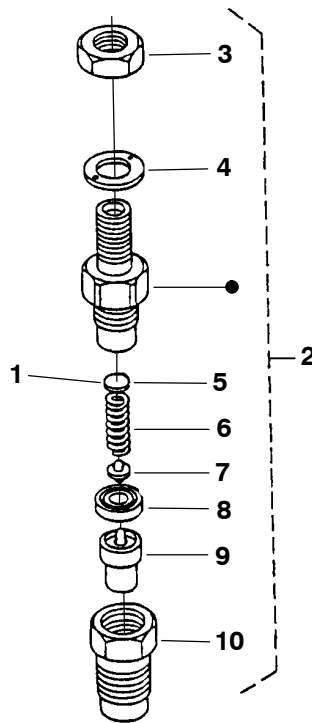

REF NO.	PART NO.	QTY USED	PART DESCRIPTION	REF NO.	PART NO.	QTY USED	PART DESCRIPTION
1	185-5363	3	Washer Assy – Includes the Following Adjusting Washers:				
	185-5364	3	0.900 mm		185-5391	3	1.575 mm
	185-5365	3	0.925 mm		185-5392	3	1.600 mm
	185-5366	3	0.950 mm		185-5393	3	1.625 mm
	185-5367	3	0.975 mm		185-5394	3	1.650 mm
	185-5368	3	1.000 mm		185-5395	3	1.675 mm
	185-5369	3	1.025 mm		185-5396	3	1.700 mm
	185-5370	3	1.050 mm		185-5397	3	1.725 mm
	185-5371	3	1.075 mm		185-5398	3	1.750 mm
	185-5372	3	1.100 mm		185-5399	3	1.775 mm
	185-5373	3	1.125 mm		185-5400	3	1.800 mm
	185-5374	3	1.150 mm		185-5401	3	1.825 mm
	185-5375	3	1.175 mm		185-5402	3	1.850 mm
	185-5376	3	1.200 mm		185-5403	3	1.875 mm
	185-5377	3	1.225 mm		185-5404	3	1.900 mm
	185-5378	3	1.250 mm		185-5405	3	1.925 mm
	185-5379	3	1.275 mm		185-5406	3	1.950 mm
	185-5380	3	1.300 mm	2	185-6738	3	Holder Assy, Nozzle (Includes Parts Marked *)
	185-5381	3	1.325 mm	3	185-5616	3	*Nut, Hex
	185-5382	3	1.350 mm	4	185-5621	3	*Washer
	185-5383	3	1.375 mm	5	185-5364	3	*Washer, Adjusting
	185-5384	3	1.400 mm	6	185-5617	3	*Spring
	185-5385	3	1.425 mm	7	185-5619	3	*Rod, Push
	185-5386	3	1.450 mm	8	185-5618	3	*Spacer
	185-5387	3	1.475 mm	9	185-5622	3	*Nozzle
	185-5388	3	1.500 mm	10	185-6825	3	*Nut, Nozzle
	185-5389	3	1.525 mm				
	185-5390	3	1.550 mm				

* – Parts Included in Nozzle Holder Assy.

Rocker Arm

HDKAH, HDKAJ, HDKAK Spec A-H
HDKAT, HDKAU, HDKAV Spec A-E

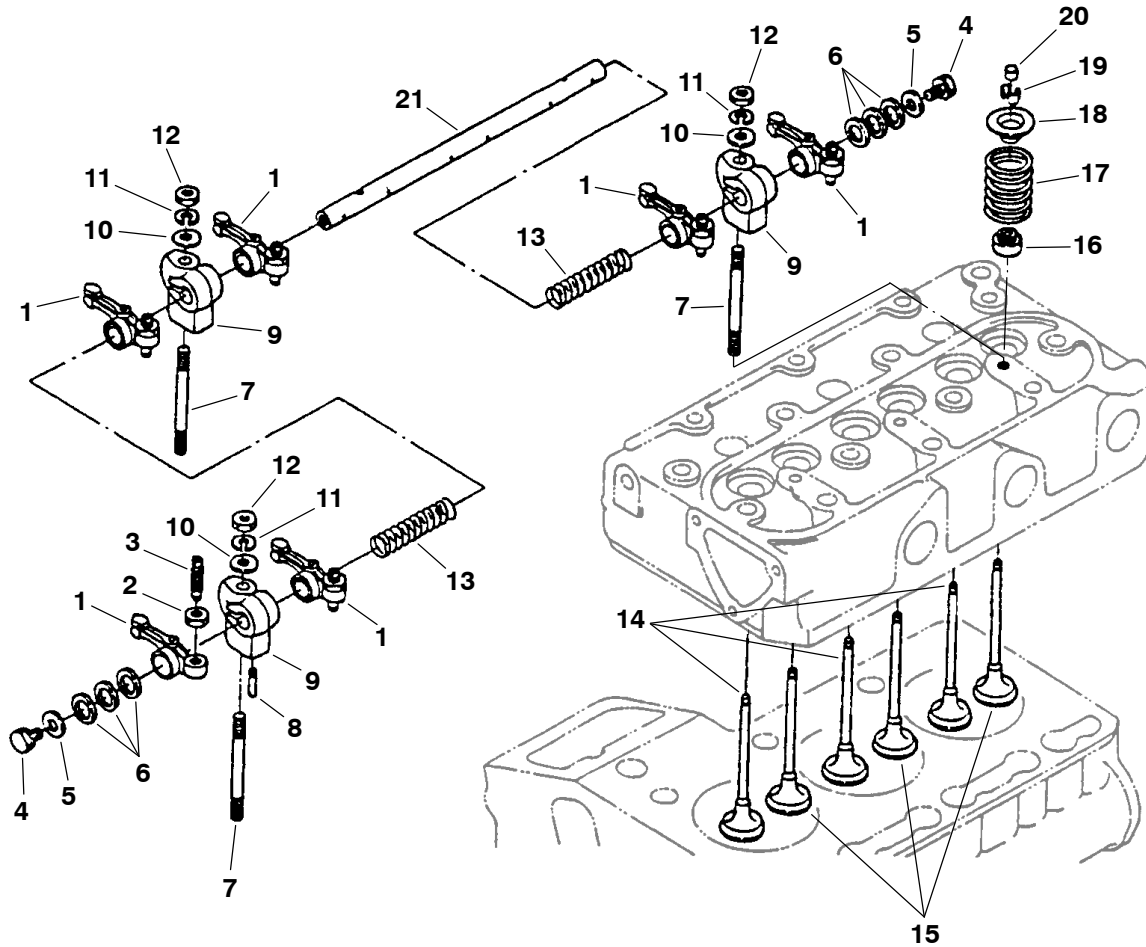

REF NO.	PART NO.	QTY USED	PART DESCRIPTION	REF NO.	PART NO.	QTY USED	PART DESCRIPTION
1	185-5551	6	Arm, Rocker (Includes Nut and Screw)	11	185-6759	3	Washer, Spring Lock
2	185-5553	6	Nut	12	185-4255	3	Nut, Flange
3	185-5552	6	Screw, Adjusting	13	185-5550	2	Spring, Rocker Arm
4	185-2386	2	Screw, Hex Head Cap (M6 x 12mm)	14	185-5537	3	Valve, Intake
5	185-5545	2	Washer, Flat	15	185-5538	3	Valve, Exhaust
6	185-7086	6	Washer, Flat	16	185-5348	6	Seal, Valve Stem
7	185-5547	3	Stud	17	185-5539	6	Spring, Valve
8	185-2351	1	Pin, Spring	18	185-5540	6	Retainer, Valve Spring
9	185-5546	3	Bracket, Rocker Arm	19	185-5541	6	Collet, Valve Spring
10	526-2080	3	Washer, Flat (M6)	20	185-5542	6	Cap, Valve
				21	185-7085	1	Shaft, Rocker Arm

Rocker Arm
HDKAH, HDKAJ, HDKAK Begin Spec J
HDKAT, HDKAU, HDKAV Begin Spec F

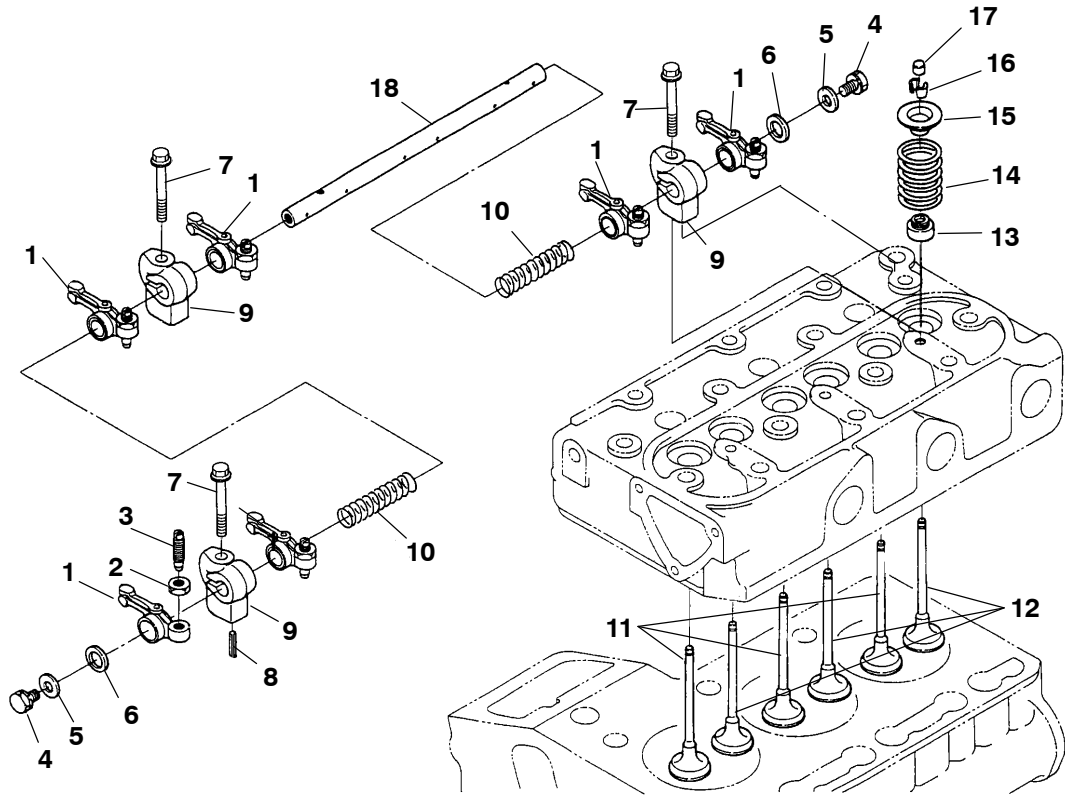

REF NO.	PART NO.	QTY USED	PART DESCRIPTION	REF NO.	PART NO.	QTY USED	PART DESCRIPTION
1	185-5551	6	Arm, Rocker (Includes Nut and Screw)	9	181-9251	3	Bracket, Rocker Arm
2	185-5553	6	Nut	10	185-5550	2	Spring, Rocker Arm
3	185-5552	6	Screw, Adjusting	11	185-5537	3	Valve, Intake
4	185-2386	2	Screw, Hex Head Cap (M6 x 12mm)	12	185-5538	3	Valve, Exhaust
5	185-7395	2	Washer, Flat	13	185-5348	6	Seal, Valve Stem
6	185-7086	6	Washer, Flat	14	185-5539	6	Spring, Valve
7	800-6372	3	Bolt, Flange	15	185-5540	6	Retainer, Valve Spring
8	185-2351	1	Pin, Spring	16	185-5541	6	Collet, Valve Spring
				17	185-5793	6	Cap, Valve
				18	185-7085	1	Shaft, Rocker Arm

Governor

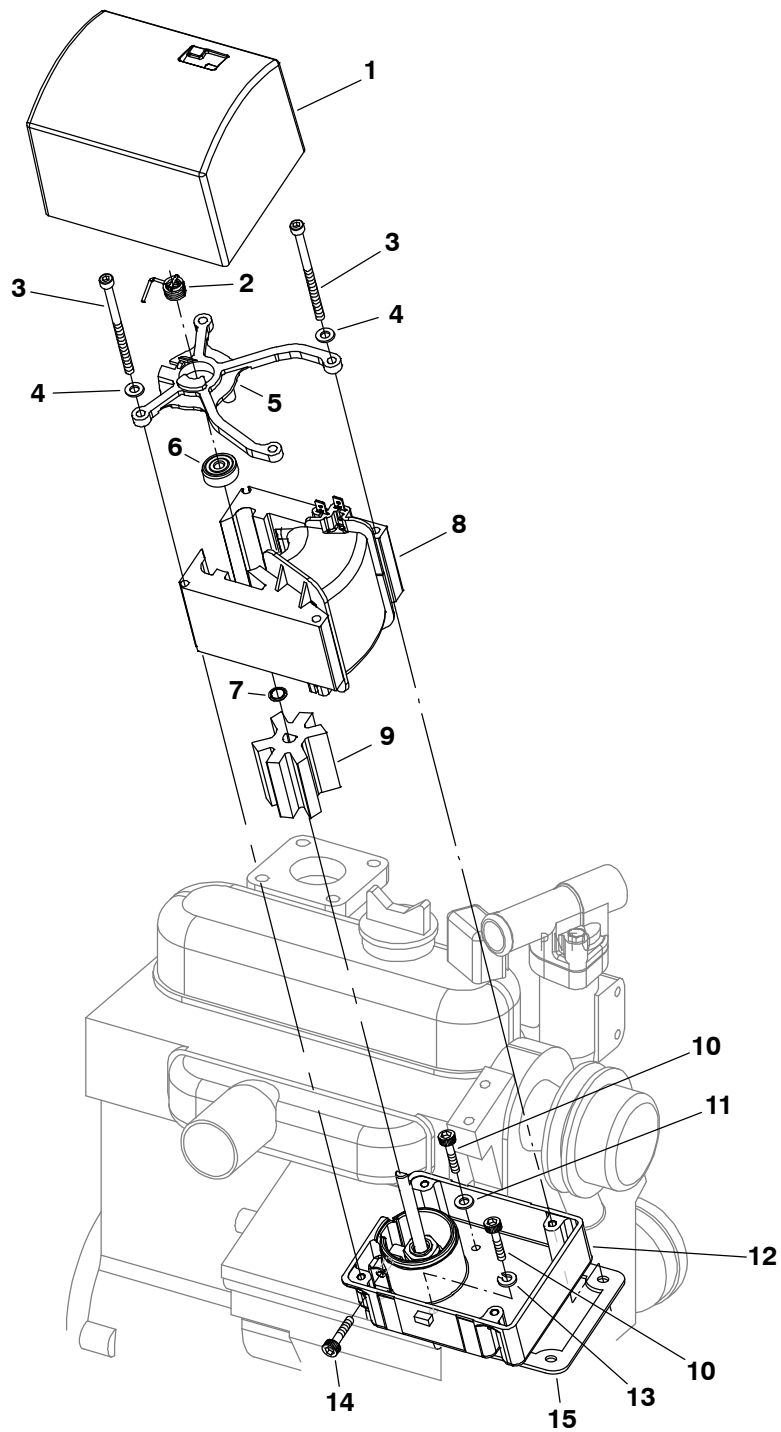

REF NO.	PART NO.	QTY USED	PART DESCRIPTION	REF NO.	PART NO.	QTY USED	PART DESCRIPTION
1	150-2641	1	Cover, Governor	9	150-2639	1	Rotor, Governor
2	150-2724	1	Spring, Governor	10	725-1027	4	Screw, Socket Head Cap (M6-16)
3	815-0877	4	Screw, Socket Head Cap (M5 x .8 x 80mm)	11	185-2284	2	Gasket
4	740-1002	4	Washer, Flat (M5)	12	185-7267	1	Base, Governor
5	150-2643-S0	1	Carrier Assy (Includes Bearing)	13	850-2006	2	Washer, Lock (M6)
6	510-0184	1	Bearing, Ball	14	802-2506	3	Screw, Socket Set (M5 x .8 x 16mm)
7	518-0672	1	O'Ring, Governor Rotor	15	185-7080	1	Gasket, Governor Base
8	150-2630	1	Coil, Governor				

Water Outlet

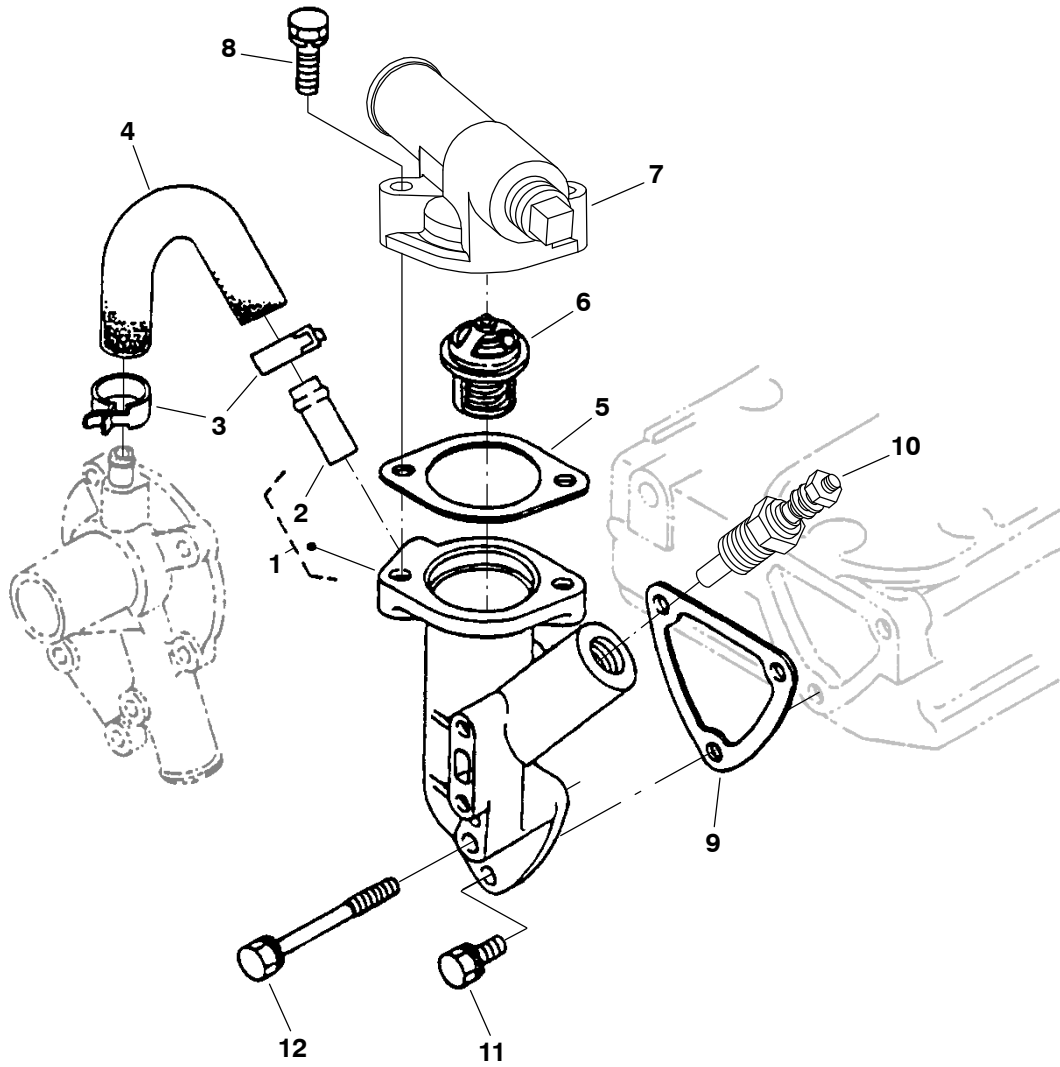

REF NO.	PART NO.	QTY USED	PART DESCRIPTION	REF NO.	PART NO.	QTY USED	PART DESCRIPTION
1	181-9185	1	Flange, Water Pump (Includes Water Return Pipe)	7	181-9196	1	Cover, Thermostat
2	185-5719	1	Pipe, Water Return	8	185-6669	2	Bolt
3	185-5723	2	Band, Pipe	9	130-6904	1	Gasket, Water Flange
4	185-5722	1	Pipe, Water Return	10	193-0318	1	Sender, Water Temperature
5	185-2238	1	Gasket, Thermostat	11	185-2388	2	Bolt (M6 x 16mm)
6	185-5458	1	Thermostat	12	185-7069	1	Bolt

Valve Cover
HDKAH, HDKAJ, HDKAK Spec A-H
HDKAT, HDKAU, HDKAV Spec A-E

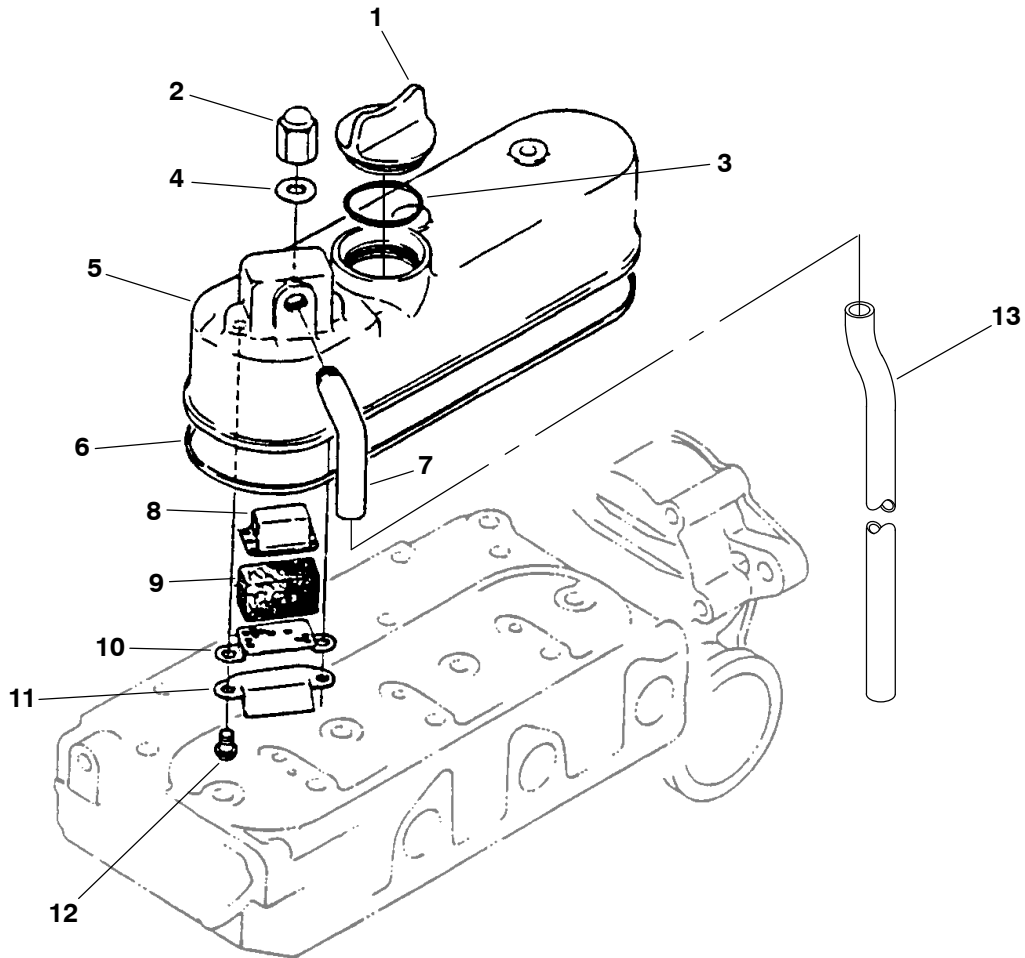

REF NO.	PART NO.	QTY USED	PART DESCRIPTION	REF NO.	PART NO.	QTY USED	PART DESCRIPTION
1	185-5407	1	Cap, Oil Fill	8	185-5522	1	Cover, Breather Element
2	185-5529	3	Nut, Cap	9	185-5523	1	Element, Breather
3	185-2349	1	Seal, Oil Fill Cap	10	185-5521	1	Plate, Breather Element
4	185-2284	3	O'Ring	11	185-5524	1	Shield, Breather Oil
5	185-7071	1	Cover, Valve	12	185-5747	2	Screw, Pan Head Lock Washer
6	185-5807	1	Gasket, Valve Cover	13	185-5525	1	Hose, Breather
7	185-5520	1	Elbow, Breather				

Valve Cover
HDKAH, HDKAJ, HDKAK Begin Spec J
HDKAT, HDKAU, HDKAV Begin Spec F

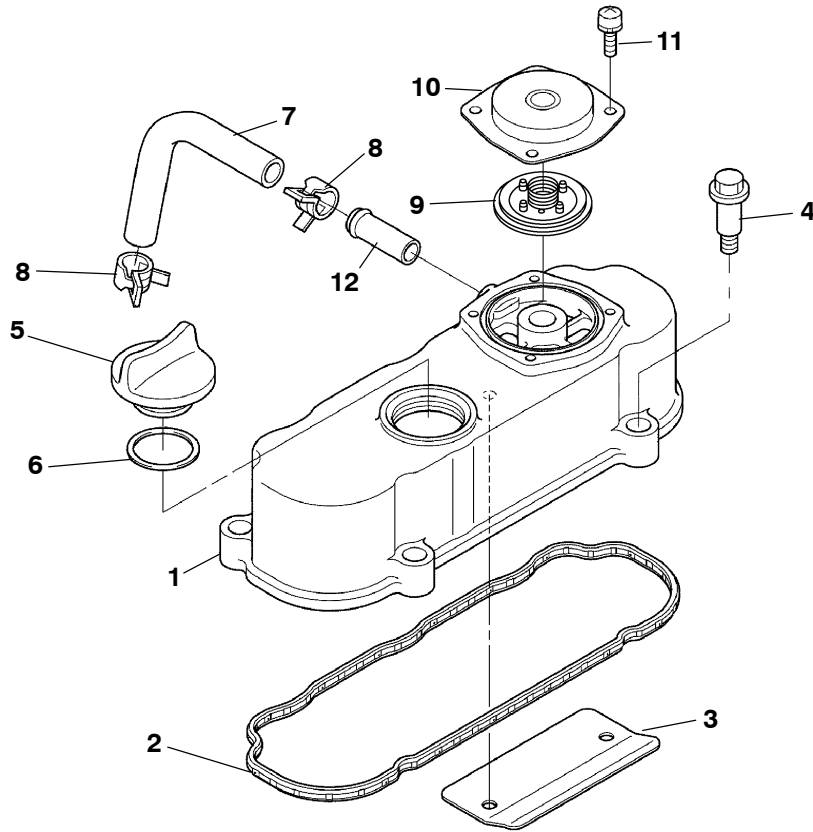

REF NO.	PART NO.	QTY USED	PART DESCRIPTION	REF NO.	PART NO.	QTY USED	PART DESCRIPTION
1	181-9252	1	Assy, Cover Cylinder Head	7	181-9249	1	Tube, Breather
2	181-9253	1	Gasket, Head Cover	8	185-5162	2	Clamp, Hose
3	123-2303	1	Shield, Breather Oil	9	123-2264	1	Comp. Valve, Breather
4	800-6330	4	Bolt	10	123-2268	1	Cover, Breather
5	181-9000	1	Plug, Oil Fill	11	185-2384	4	Screw, Flanger
6	185-7426	1	O'Ring	12	185-5719	1	Pipe, Water Return

Gearcase

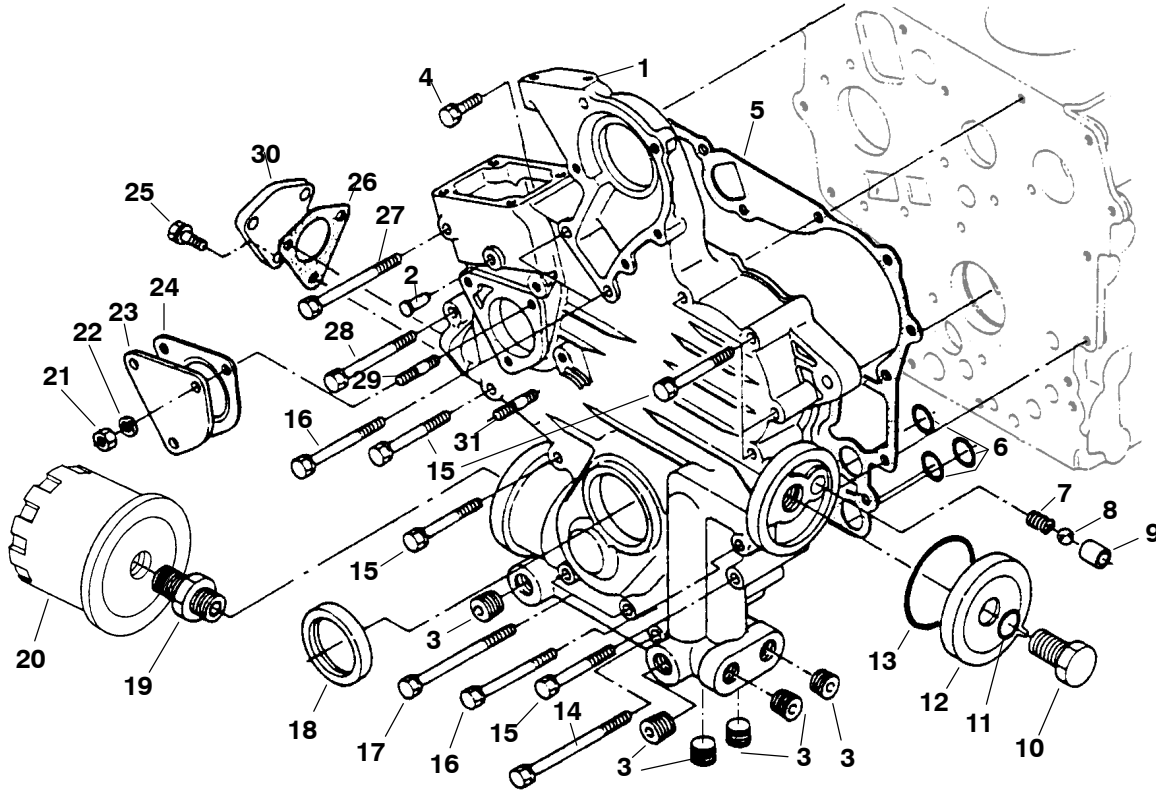

REF NO.	PART NO.	QTY USED	PART DESCRIPTION	REF NO.	PART NO.	QTY USED	PART DESCRIPTION
1	185-5800	1	Gearcase Assy (Includes Pin and Plugs)	19	185-2124	1	Nipple, Hex Pipe
2	185-5506	1	Pin, Start Spring	20	122-0833	1	Filter, Oil (was 185-5801)
3	185-5505	8	Plug, Pipe	21	185-4255	3	Nut, Hex
4	185-2389	1	Screw, Hex Head Cap (M6 x 18mm)	22	185-6759	3	Washer, Spring Lock
5	185-7382	1	Gasket, Gearcase	23	185-5512	1	Cover
6	185-2374	3	O'Ring	24	185-5513	1	Gasket
7	185-5509	1	Spring	25	185-2389	3	Bolt (M6 x 18mm)
8			Ball	26			Gasket, Flange
			HDKAH, HDKAJ, HDKAK		185-2309	1	HDKAH, HDKAJ, HDKAK
	185-6711	1	Spec A-H		185-2309	1	Spec A-H
	185-5511	1	Begin Spec J		181-9211	1	Begin Spec J
			HDKAT, HDKAU, HDKAV		185-2309	1	Spec A-E
	185-6711	1	Spec A-E		181-9211	1	Begin Spec F
	185-5511	1	Begin Spec F	27	185-7070	1	Screw, Hex Head Cap (M6 x 70mm)
9	185-5510	1	Seat, Valve	28	185-2395	1	Bolt (M6 x 60mm)
10	185-5742	1	Bolt	29	185-2105	3	Stud
11	185-5744	1	O'Ring	30			Cover
12	185-5741	1	Cover		185-6257	1	HDKAH, HDKAJ, HDKAK
13	185-5743	1	O'Ring		181-9213	1	Spec A-H
14	185-5746	1	Screw, Hex Head Cap (M6 x 1 x 87mm)				Begin Spec J
15	185-7069	7	Screw, Hex Head Cap (M6 x 50mm)		185-6257	1	HDKAT, HDKAU, HDKAV
16	185-5507	3	Screw, Hex Head Cap (M6 x 1 x 62mm)		185-6257	1	Spec A-E
17	185-5745	2	Bolt		181-9213	1	Begin Spec F
18	185-5410	1	Seal, Front Oil	31	185-5727	1	Stud

Water Pump Components

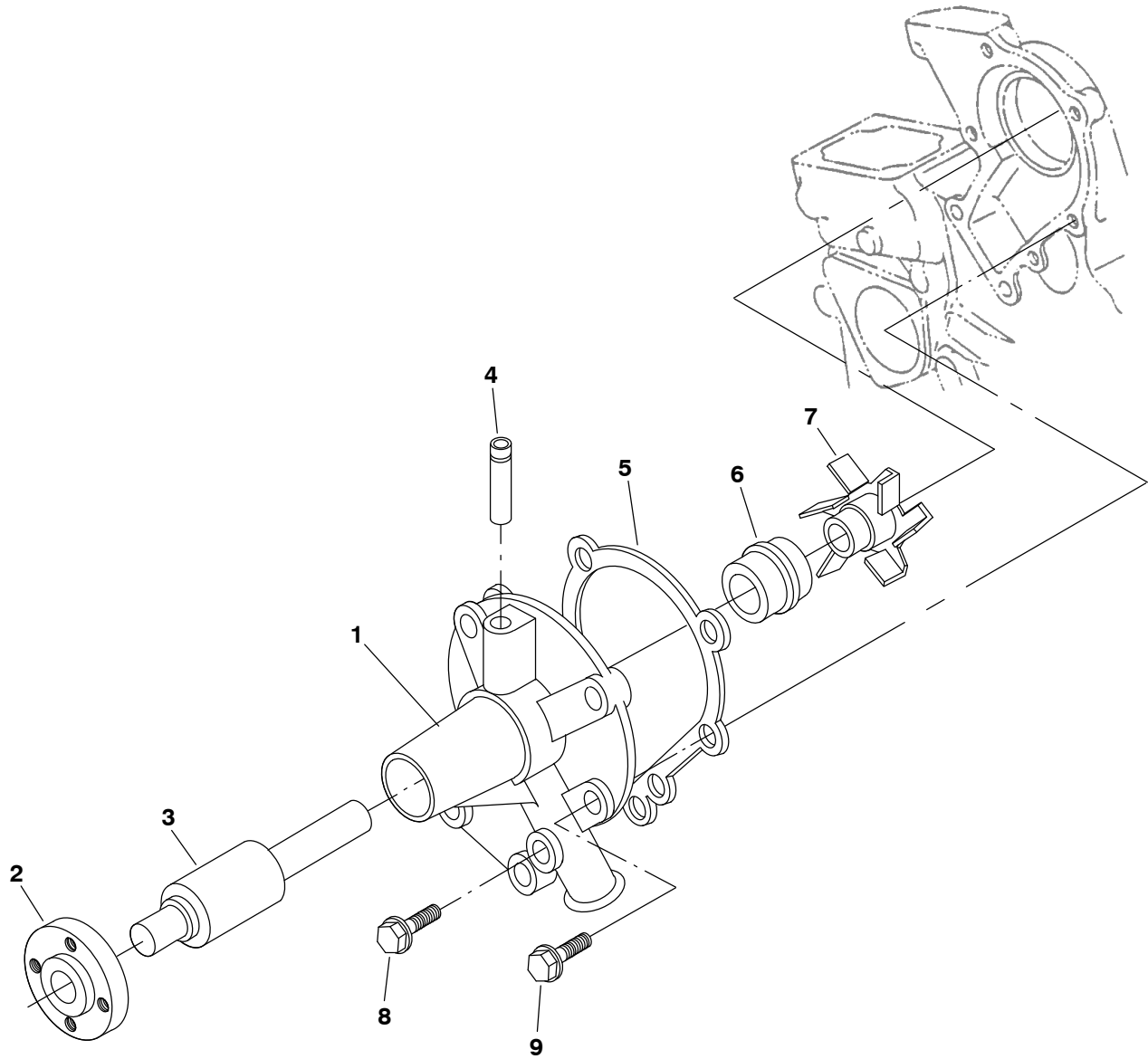

REF NO.	PART NO.	QTY USED	PART DESCRIPTION	REF NO.	PART NO.	QTY USED	PART DESCRIPTION
1	185-5433	1	Pump, Water (Includes Parts Marked *)	7	185-5715	1	*Impeller
2	185-5712	1	*Flange, Water Pump	8	185-5717	1	Bolt
3	185-5713	1	*Bearing, Ball	9	185-2559	4	Bolt
4	185-5716	1	*Pipe, Return				
5	185-5434	1	Gasket, Water Pump				
6	185-5714	1	*Seal				

* - Parts Included in Water Pump.

Fuel System

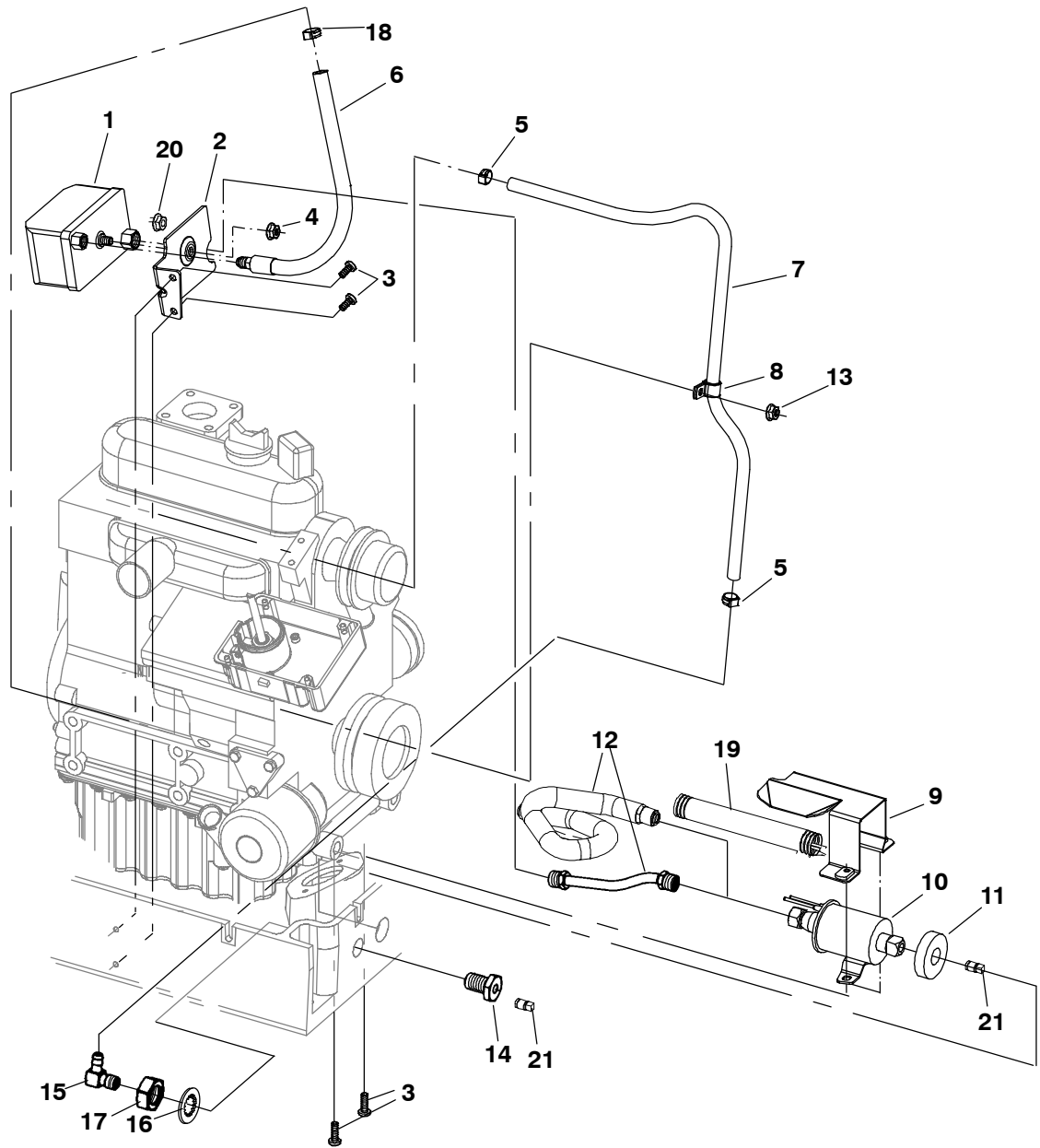

REF NO.	PART NO.	QTY USED	PART DESCRIPTION	REF NO.	PART NO.	QTY USED	PART DESCRIPTION
1	149-2513	1	Filter, Fuel	14	502-1296-02	1	Fitting, Bulkhead
2	149-2585-02	1	Bracket, Fuel Filter	15	502-0313	1	Elbow, 90°
3	815-0753	4	Screw, Hex Head Cap (M6 x 14mm)	16	854-0028	1	Washer, IT Lock (5/8")
4	870-0257	1	Nut, Self Lock (1/4-20)obsolete	17	868-0007	1	Nut, Hex Jam (5/8-18)
5	503-1951-09	2	Clamp, Hose	18	503-1951-12	1	Clamp, Hose
6	149-2580	1	Line, Fuel Injection Pump	19	898-1196-33	1	Sleeve, Fuel Line (begin Spec K all models)
7	503-2052	1	Line, Fuel Return	20	870-0257	1	Nut, Self locking Flange (1/4-20 UNC begin Spec K all models)
8	332-1554	1	Clamp, Loop	21	517-0273	2	Plug, Pipe (begin Spec K all models)
9	403-3863-02	1	Trough, Oil Drain				
10	149-2790	1	Pump, Fuel				
11	403-3860	1	Seal, Fuel Pump				
12			Line, Fuel Filter (All Models)				
	149-2584	1	Spec A-J				
	501-0932	1	Begin Spec K				
13	870-2054	1	Nut, Lock Flange (M6 x 1)				

Air Intake

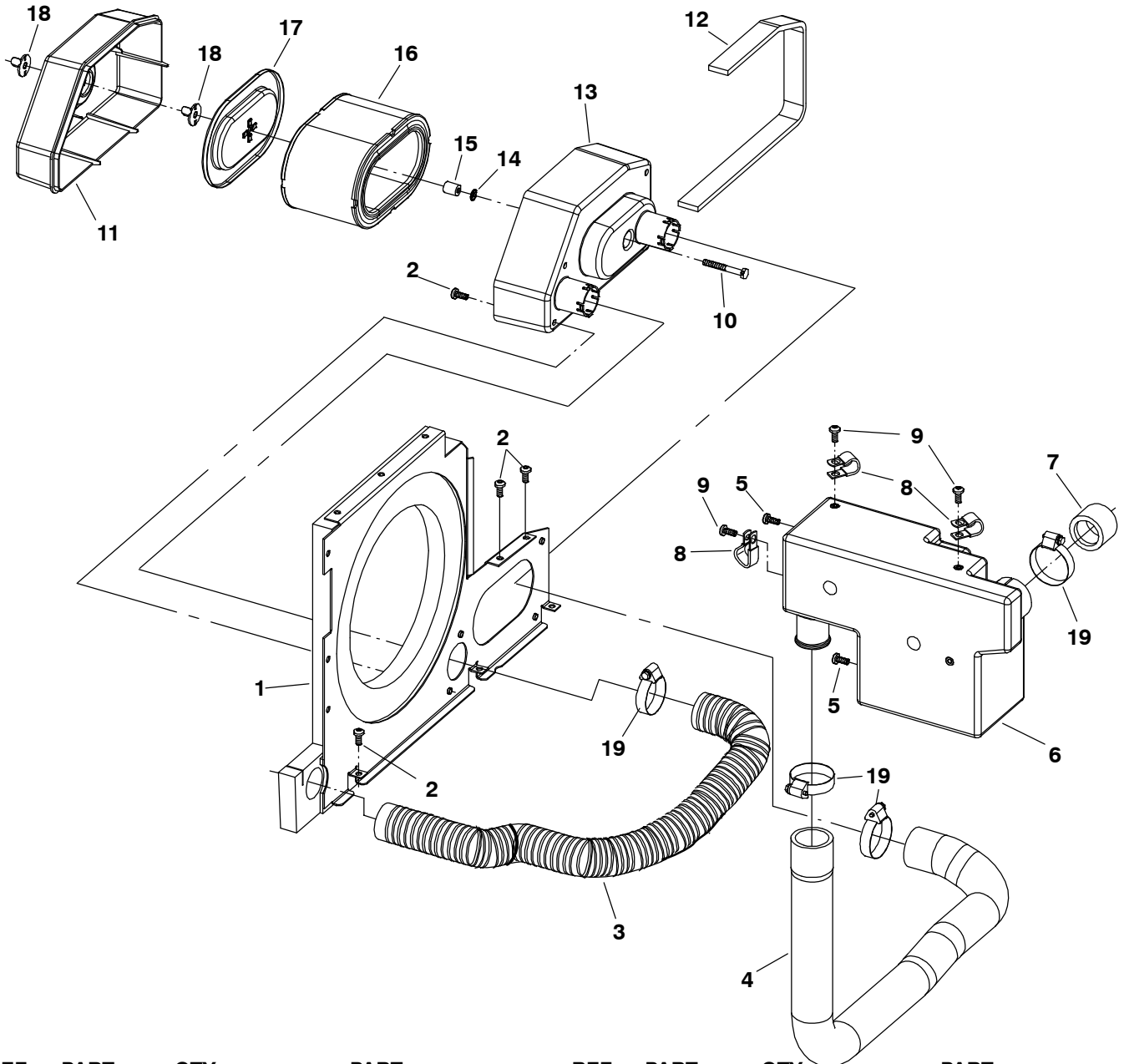

REF NO.	PART NO.	QTY USED	PART DESCRIPTION	REF NO.	PART NO.	QTY USED	PART DESCRIPTION
	140-3233	1	Kit, Air Cleaner (Includes Parts Marked*)	10	800-0603-01	1	Screw, Hex Head Machine (1/4-20 x 2)
1	134-5063	1	Baffle Assy, Inlet (Includes Insulation)	11	140-3232	1	*Cover, Air Cleaner
2	823-0003-02	7	Screw, Pan Head (M6 x 1 x 14mm)	12	140-2956	1	*Seal, Housing
3	503-1979	1	Hose, Intake (Dirty 43.2OD)	13	140-3231	1	*Housing, Air Cleaner
4	503-1985	1	Hose, Intake (Clean)	14	870-0540-03	1	Nut, Push-On
5	823-1002-04	2	Screw, Pan Head Machine (M6 x 1 x 14mm)	15	140-2536-05	1	Seal, Air Cleaner Spacer
6	134-5126	1	Resonator, Intake	16	140-2897	1	Element, Air Cleaner
7	140-2898	1	Sleeve, Air Intake	17	140-2961-02	1	Cover, Air Cleaner Element
8	332-1356	3	Clamp, Loop (3/4")	18	865-0029	2	Nut, Wing (1/4-20)
9	823-1002-03	3	Screw, Pan Head Machine (M6 x 1 x 10mm)	19	503-0429	4	Clamp, Hose

Cooling System

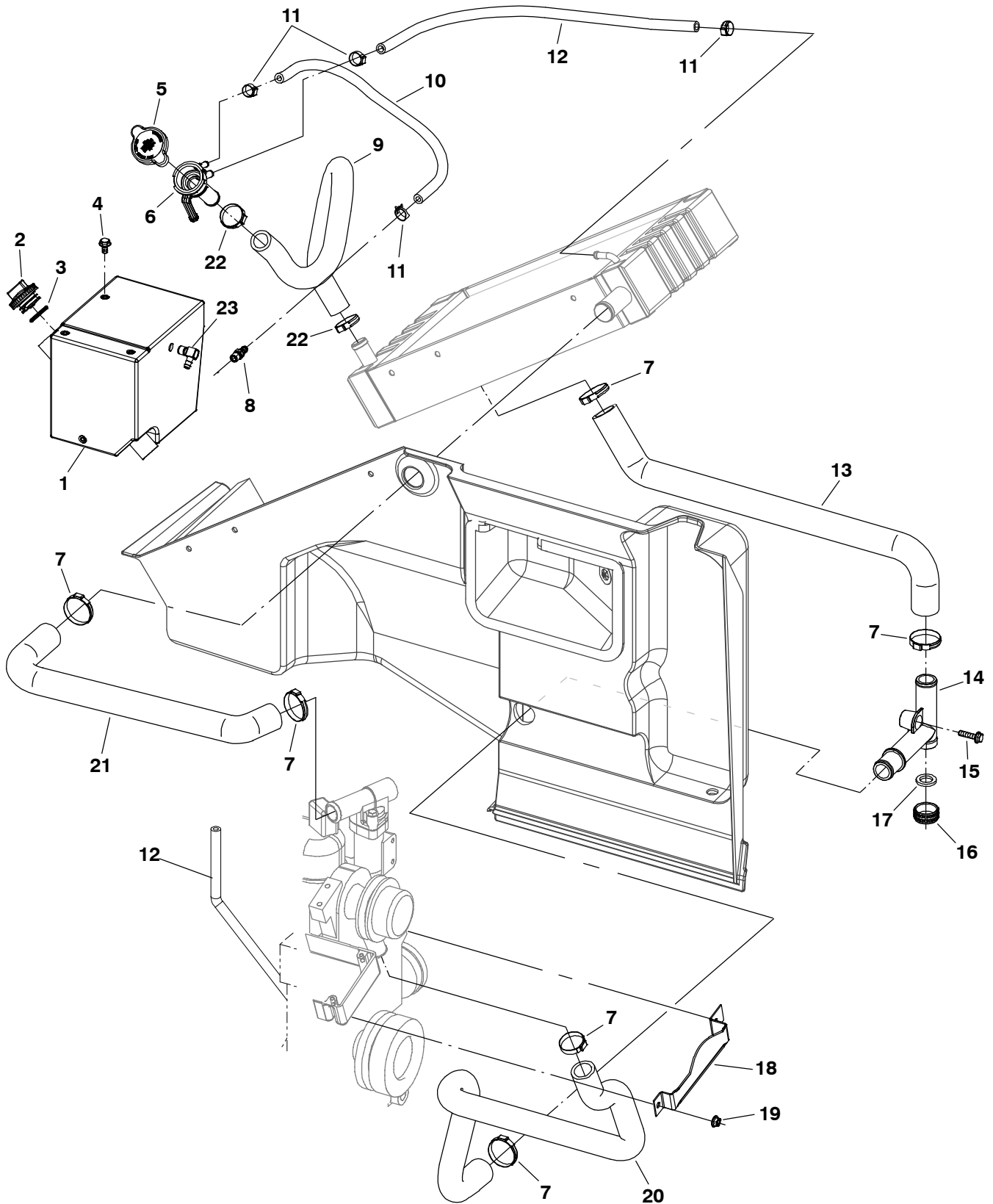

Cooling System

REF NO.	PART NO.	QTY USED	PART DESCRIPTION	REF NO.	PART NO.	QTY USED	PART DESCRIPTION
1	130-4322	1	Tank, Coolant Recovery	13	503-1954	1	Hose, Lower Radiator
2	130-4450-02	1	Cap, Coolant Recovery Tank	14	130-4391	1	Fitting, "T" Hose
3	509-0329	1	O'Ring	15	821-2035	1	Screw, Lock Flange (M6 x 1 x 25mm)
4	821-2096-02	3	Screw, Lock Flange (M6 x 1 x 12mm)	16	130-4392	1	Cap, Drain
5	130-7902	1	Cap, Coolant Fill	17	130-4462	1	Seal, Coolant Hose
6	130-4321	1	Neck, Fill	18	503-1970-02	1	Clamp, Hose Bracket
7	503-1137	5	Clamp, Hose	19	870-2054	1	Nut, Lock Flange (M6 x 1)
8	502-1367-01	1	Connector, Hose	20	503-1921	1	Hose, Lower Engine
9	503-1922	1	Hose, Fill Neck	21	503-1920	1	Hose, Upper Radiator
10	503-1923	1	Hose, Overflow	22	503-1951-35	2	Clamp, Hose
11	503-1951-12	4	Clamp, Hose	23	502-1529	1	Connector, Hose (90° Nylon 1/8 x 1/4" Hose)
12	503-1959	2	Hose, Air Bleed				

Radiator Mount

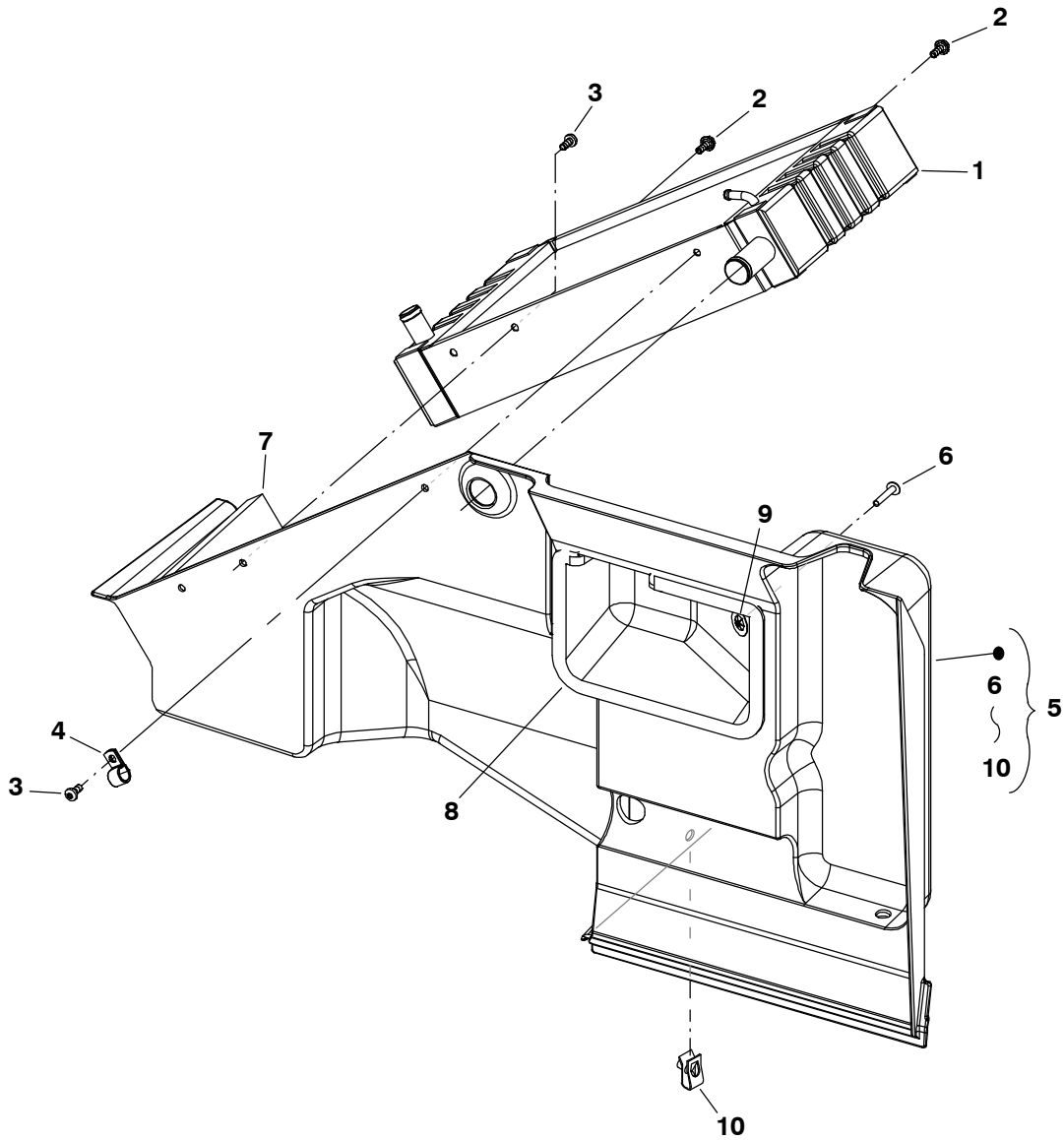

REF NO.	PART NO.	QTY USED	PART DESCRIPTION	REF NO.	PART NO.	QTY USED	PART DESCRIPTION
1	130-6936	1	Radiator	6	818-0226-01	2	*Rivet
2	815-0753	2	Screw, Hex Head (M6 x 14mm Self Tap)	7	130-4689	1	*Seal, Radiator Spacer
3	821-2096-03	2	Screw, Locking Flange (M6 x 1 x 16mm)	8	405-5308	1	*Insulation, Exhaust Baffle
4	332-1553	1	Clamp, Loop (1")	9	518-0581	2	*Nut, Push-On
5	405-5086	1	Wall Assy, Back (Includes Parts Marked *)	10	870-0542	1	*Nut, Self Retaining

* - Parts Included in Back Wall Assy.

Oil Pan
HDKAH, HDKAJ, HDKAK Spec A-H
HDKAT, HDKAU, HDKAV Spec A-E

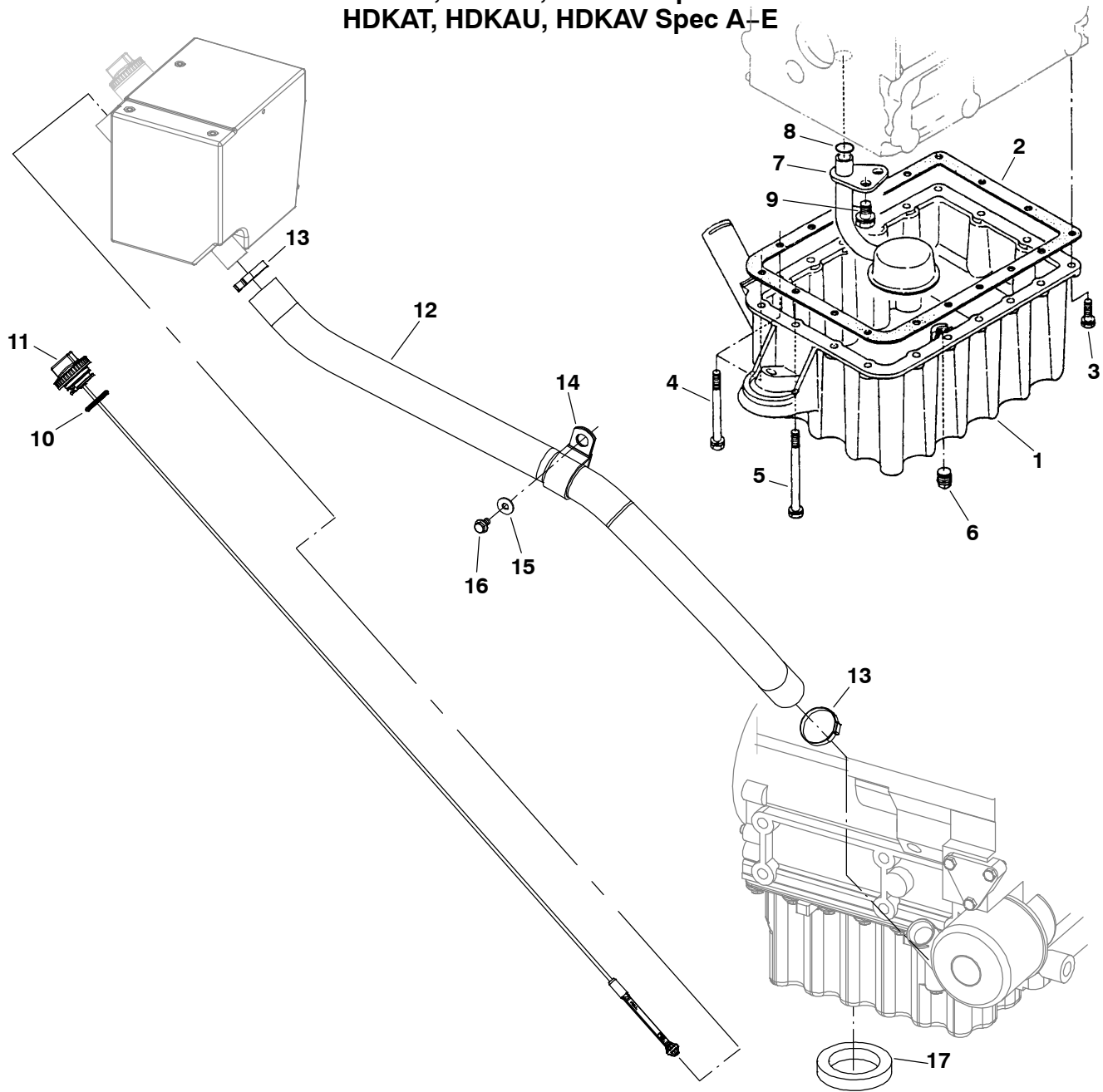

REF NO.	PART NO.	QTY USED	PART DESCRIPTION	REF NO.	PART NO.	QTY USED	PART DESCRIPTION
1	185-6846	1	Pan, Oil				(Includes O'Ring)
2	185-6818	1	Gasket, Oil Pan	12	123-2120	1	Hose, Oil Fill
3	185-2389	15	Bolt	13	503-1951-46	2	Clamp, Hose
4	185-2396	2	Bolt	14	332-2898	1	Clamp, Loop (1.44")
5	185-2398	1	Bolt	15	526-2083	1	Washer, Flat (M6)
6	502-0153	1	Plug, Oil Drain	16	821-2032	1	Screw, Lock Flange (M6 x 1 x 12mm)
7	185-5496	1	Tube, Oil Pickup	17	403-3859	1	Seal, Oil Drain
8	185-3078	1	O'Ring				
9	185-6956	1	Bolt				
10	509-0329	1	O'Ring				
11	123-2051	1	Indicator, Oil Level All Specs				

Oil Pan
HDKAH, HDKAJ, HDKAK Begin Spec J
HDKAT, HDKAU, HDKAV Begin Spec F

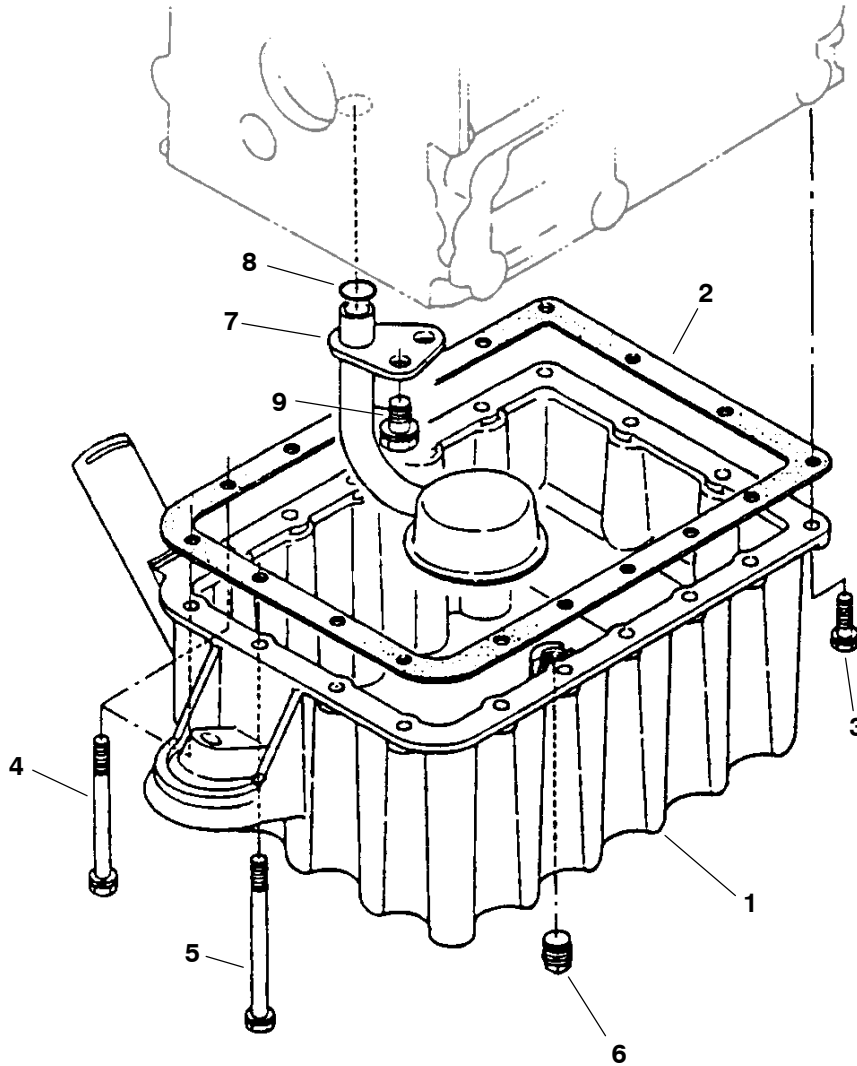

REF NO.	PART NO.	QTY USED	PART DESCRIPTION	REF NO.	PART NO.	QTY USED	PART DESCRIPTION
1	181-9200	1	Pan, Oil	6	181-9227	1	Plug, Oil Drain
2	181-9210	1	Gasket, Oil Pan	7	185-5496	1	Tube, Oil Pickup
3	185-2389	15	Bolt	8	185-7421	1	O'Ring
4	181-9005	2	Bolt	9	185-6956	1	Bolt
5	185-2398	1	Bolt				

Pulley

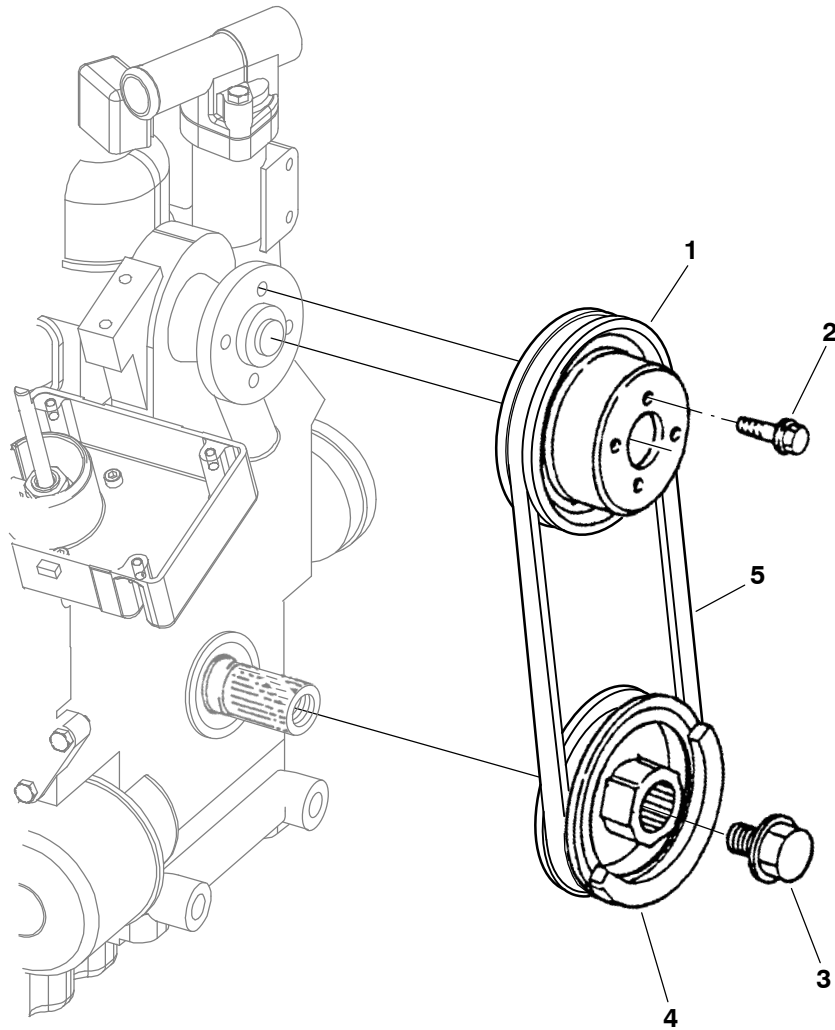

REF NO.	PART NO.	QTY USED	PART DESCRIPTION	REF NO.	PART NO.	QTY USED	PART DESCRIPTION
1	185-5707	1	Pulley, Fan	4	185-7083	1	Pulley, Drive
2	185-2572	4	Screw, Hex Head Flange	5	511-0235	1	Belt, Water Pump
3	185-5709	1	Screw, Hex Head Cap				

Inlet Manifold
HDKAH, HDKAJ, HDKAK Spec A-H
HDKAT, HDKAU, HDKAV Spec A-E

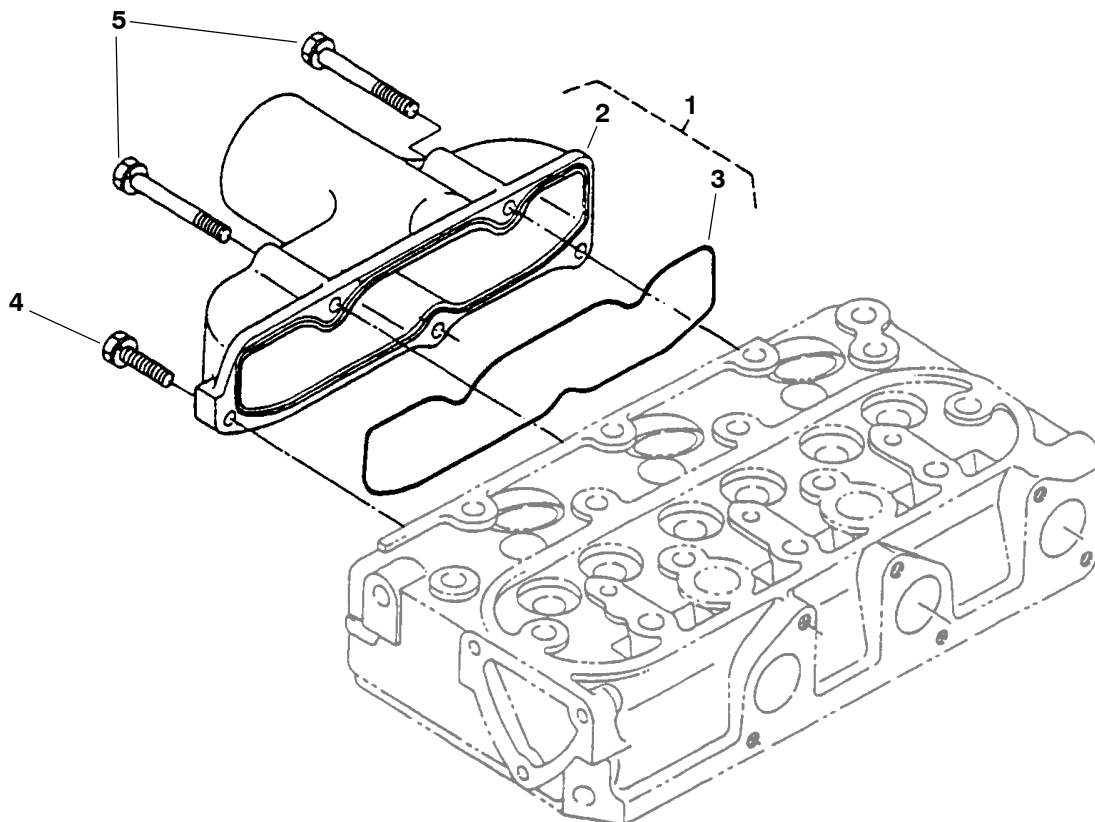

REF NO.	PART NO.	QTY USED	PART DESCRIPTION	REF NO.	PART NO.	QTY USED	PART DESCRIPTION
1	185-7087	1	Manifold Assy, Inlet (Includes Manifold and Gasket)	3	185-5832	1	Gasket, Manifold
2	185-5831	1	Manifold, Inlet	4	185-2389	2	Bolt
				5	185-5833	3	Bolt

Inlet Manifold
HDKAH, HDKAJ, HDKAK Begin Spec J
HDKAT, HDKAU, HDKAV Begin Spec F

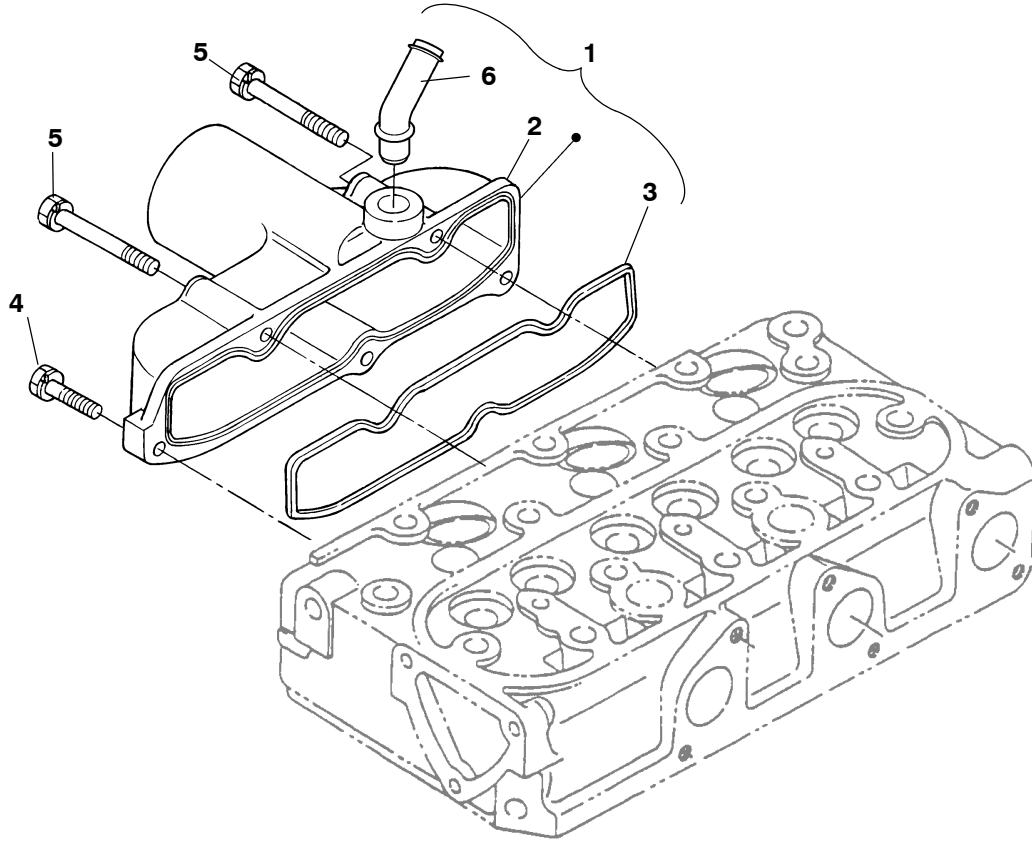

REF NO.	PART NO.	QTY USED	PART DESCRIPTION	REF NO.	PART NO.	QTY USED	PART DESCRIPTION
1	185-7087	1	Manifold Assy, Inlet (Includes Manifold and Gasket)	4	185-2389	2	Bolt
2	185-5831	1	Manifold, Inlet	5	185-5833	3	Bolt
3	185-5832	1	Gasket, Manifold	6	123-2300	1	Pipe, Breather

THIS PAGE IS INTENDED TO BE BLANK

Exhaust System

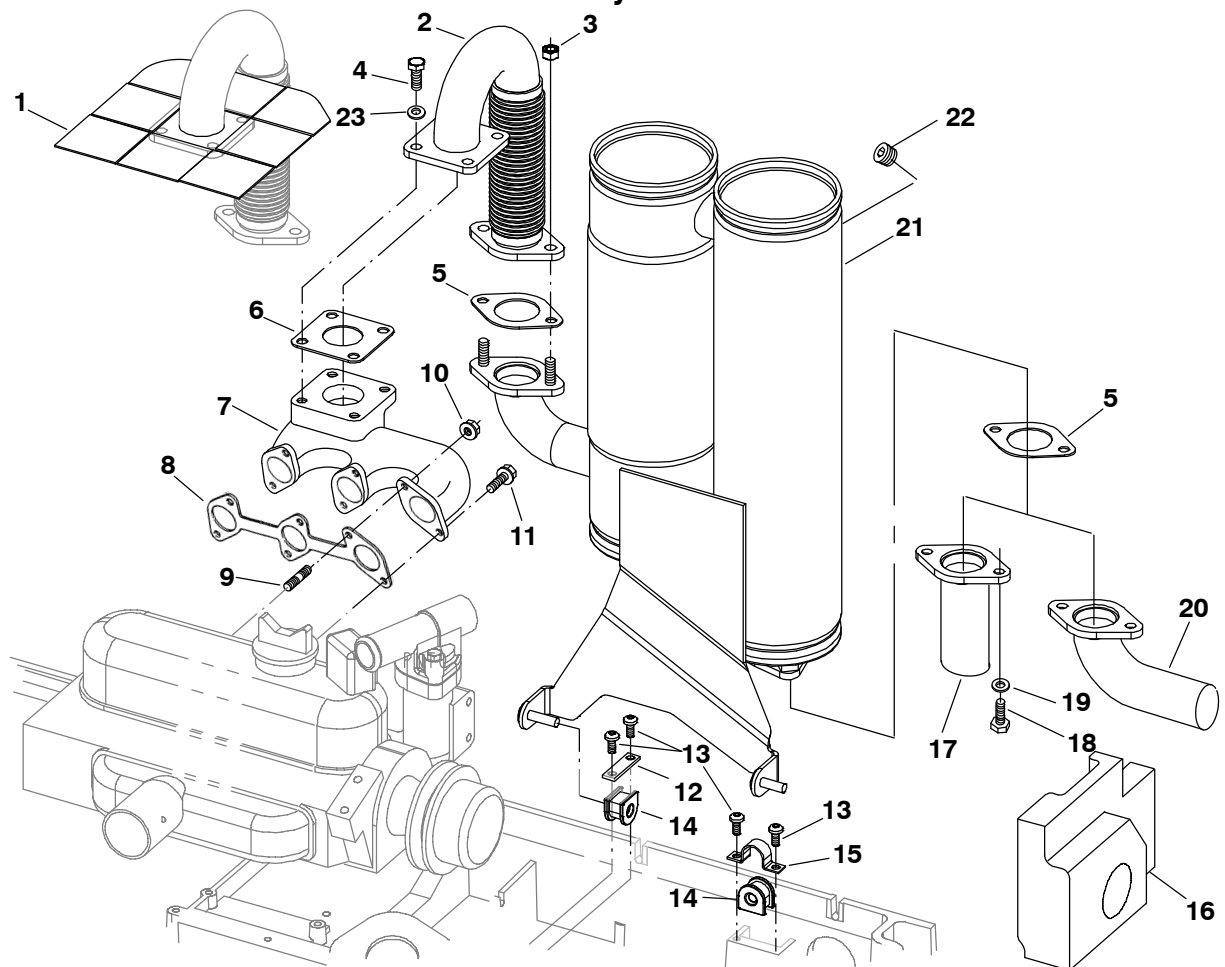

REF NO.	PART NO.	QTY USED	PART DESCRIPTION	REF NO.	PART NO.	QTY USED	PART DESCRIPTION
1	895-0297	AR	Seal, Exhaust Pipe	9	185-5829	3	Stud
2	154-3018	1	Pipe, Exhaust Flex	10	185-5536	3	Nut
3	870-0557	2	Nut, Flange Hex (M8 x 1.25mm)	11	185-5534	3	Bolt
4	725-1050	4	Screw, Socket Head Cap (M8 x 20mm)	12	402-0688-02	2	Clamp, Flat Isolator
5	154-2800	2	Gasket, Exhaust Manifold	13	823-0003-02	6	Screw, Pan Head (M6 x 1 x 14mm)
6	185-6853	1	Gasket, Muffler	14	402-0687-01	3	Isolator, Muffler
7			Manifold, Exhaust HDKAH, HDKAJ, HDKAK	15	402-0695-02	1	Clamp, "U" Isolator
	185-6791	1	Spec A-H	16	405-5787	1	Block, Fiberglass
	181-9226	1	Begin Spec J HDKAT, HDKAU, HDKAV	17		1	Tube, Exhaust 3"
	185-6791	1	Spec A-E		155-2610	1	3"
	181-9226	1	Begin Spec F		155-2424	1	7"
8			Gasket HDKAH, HDKAJ, HDKAK	18	800-0310-21	2	Screw, Hex Head Thread Form (5/16-18 x 1)
	185-6852	1	Spec A-H	19	526-0115	2	Washer, Flat (5/16")
	154-2862	1	Begin Spec J HDKAT, HDKAU, HDKAV	20	155-2982	1	Elbow, Exhaust
	185-6852	1	Spec A-E	21	155-3110	1	Muffler, Exhaust
	154-2862	1	Begin Spec F	22	505-0266	1	Plug, Clean-Out
				23	850-2008	4	Washer, Split Lock (M8)

Mounting Base

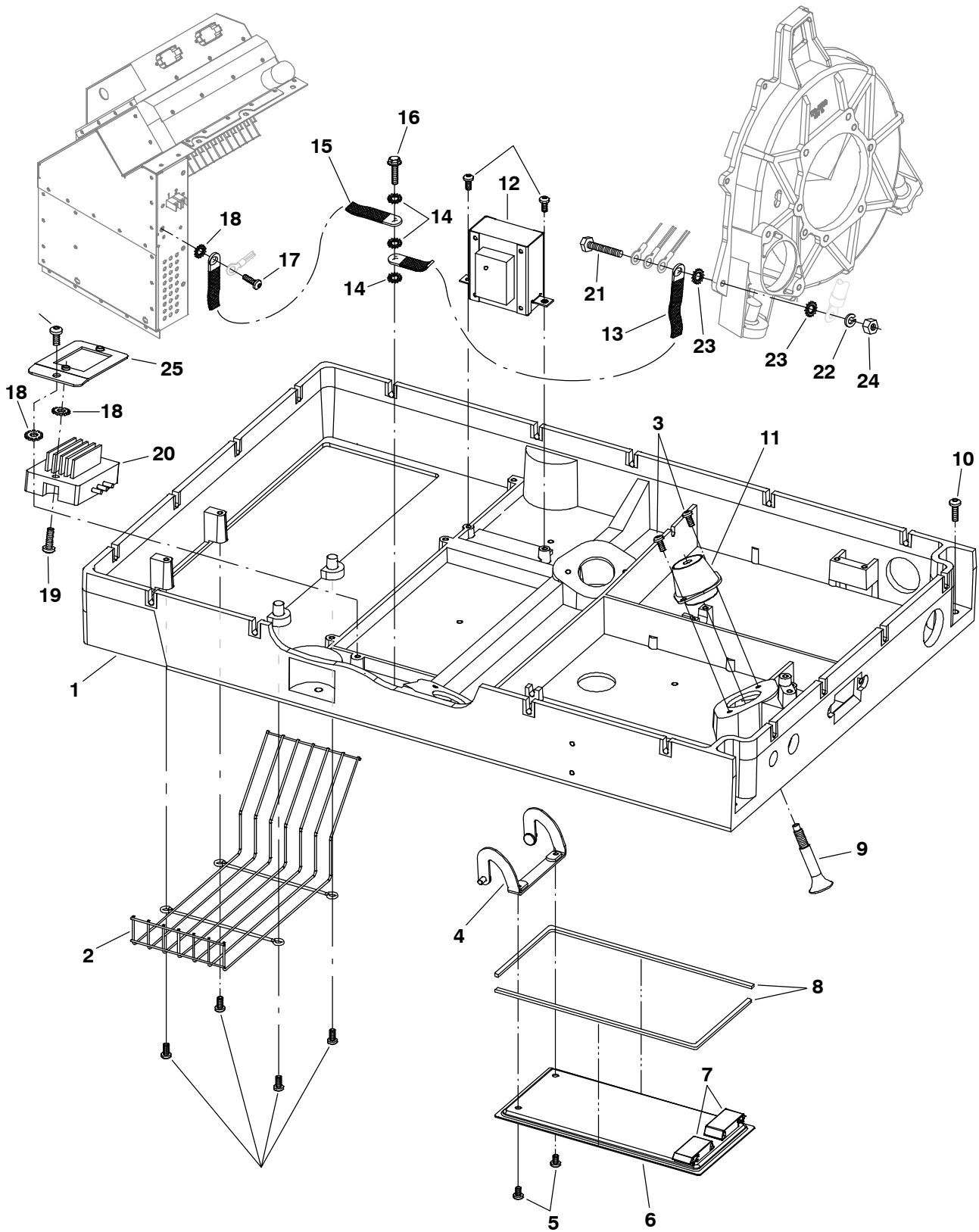

Mounting Base

REF NO.	PART NO.	QTY USED	PART DESCRIPTION	REF NO.	PART NO.	QTY USED	PART DESCRIPTION
1	403-3847-04	1	Base, Mounting	18	856-0006	3	Washer, EIT Lock (1/4")
2	130-4655	1	Guard, Fan	19	823-0003-03	8	Screw, Pan Head (M6 x 1 x 20mm)
3	823-0003-03	8/6	Screw, Pan Head Torx (M6 x 1 x 20mm)	20	191-2228	1	Regulator (For Use With Battery Charging Option)
4	402-0673-02	1	Hinge, Door	21	800-0030	1	*Screw, Hex Head Cap (5/16-18 x 1-1/4))
5	823-1002-03	2	Screw, Pan Head (M6 x 1 x 10mm)	22	850-2008	1	*Washer, Lock (M8)
6	405-5818-S0	1	Door Assy, Maintenance (Includes Latch and Seal)	23	856-0008	2	*Washer, EIT Lock (.312)
7	406-0612	2	Latch, Service Panel	24	862-0015	1	*Nut, Hex (5/16-18)
8	403-3861	2	Seal, Door	25	305-0952-02	1	Bracket, Voltage Regulator (For Use With Battery Charging Option)
9	815-0861	3	Screw, Isolator Mount	26	815-0753	7/4	Screw, Hex Head Cap (M6 x 1 x 14 Self Tap)
10	815-0908	4	Screw, Thread Forming Hex Washer Head Mounting (3/8-16 x 1.5)				
11	402-0680-01	3	Isolator, Vibration				
12	315-0793	1	Transformer, Battery Charge (For Use With Battery Charging Option)				
13	337-2845	1	Strap, Bond				
14	856-0008	3	Washer, EIT Lock (5/16")				
15	337-2953	1	Strap, Bond				
16	815-0829-05	1	Screw, Hex Washer Head Thread Forming (M8 x 1.25 x 25mm)				
17	823-1002-04	1	Screw, Pan Head Machine (M6 x 1 x 14mm)				

* - Parts Included with Engine Harness Listed on Engine Harness Page.

Housing RV (HDKAH, HDKAJ, HDKAK)

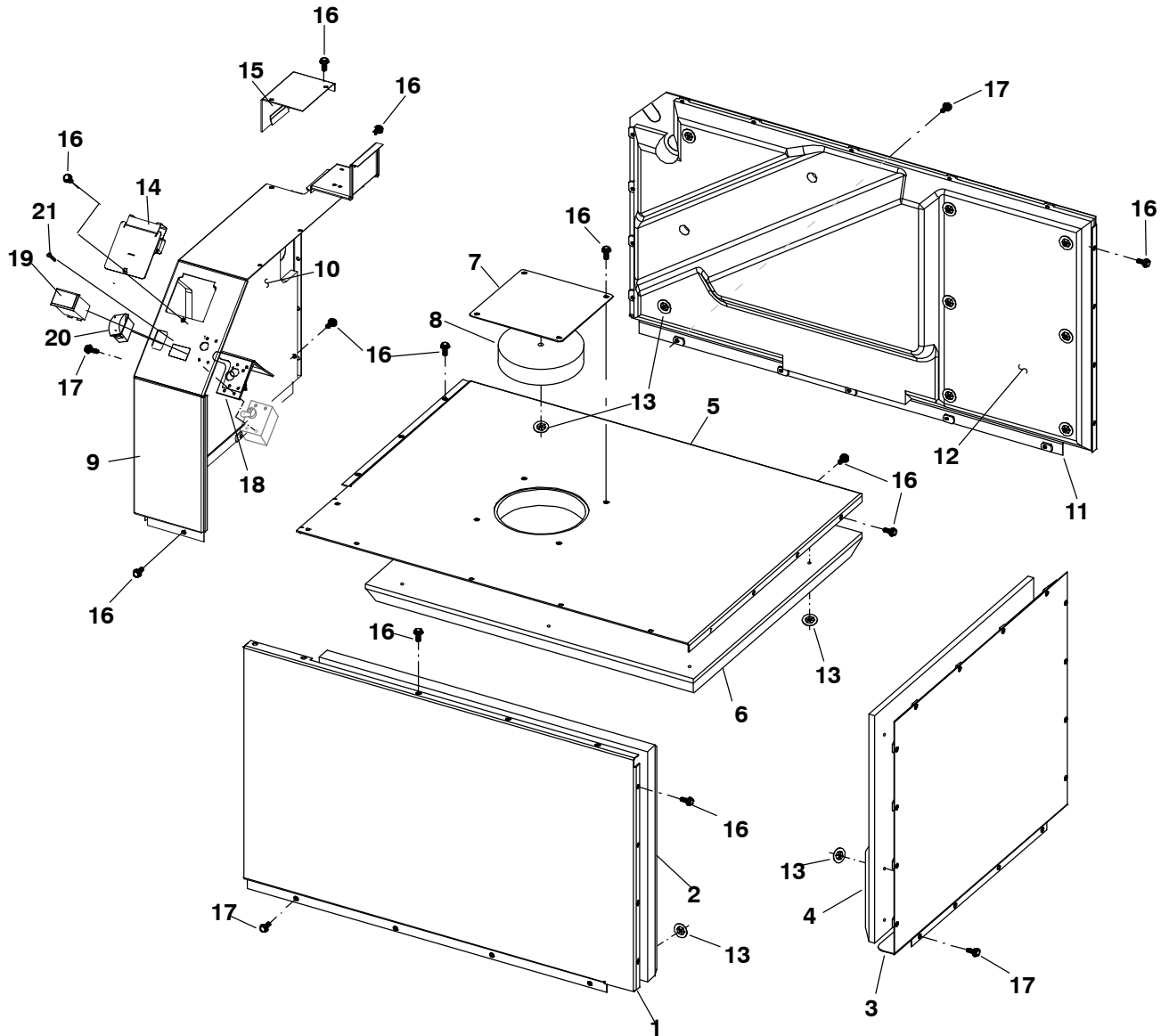

Housing Commercial Mobile (HDKAH, HDKAJ, HDKAK)

REF NO.	PART NO.	QTY USED	PART DESCRIPTION	REF NO.	PART NO.	QTY USED	PART DESCRIPTION
	405-5780	1	Kit, Insulation (Includes Parts Marked *)	13	518-0581	22	Nut, Push-On
1	405-5077-01	1	+Assy. Panel, Curb (Includes Panel and Insulation)	14	405-5309-03	1	Cover, Radiator Fill Access
2	405-5759	1	+*Insulation, Panel Curb	15	405-5380-05	1	Cover, AC Access
3	405-5080-01		#Assy. Panel, Engine (Includes Panel and Insulation)	16	821-2096-02	34	Screw, Lock Flange (M6 x 1 x 12mm)
4	405-5081	1	#*Insulation, Engine Panel	17	821-2096-03	18	Screw, Lock Flange (M6 x 1 x 16mm)
5	0404-0376-03		^Assy. Panel, Top (Includes Panel Only)	18	320-1939-02	1	Guard, Circuit Breaker
6	405-5762	1	^*Insulation, Top Panel	19	302-2002	1	Hourmeter (HDKAH and HDKAK)
7	405-5575-01	1	@Cover, Lifting Eye Access	20	308-1038	1	Switch, Rocker
8	405-5546	1	@*Insulation, Access Cover	21	815-0550-01	4	Screw, Pan Head (6-32 x 3/8")
9			>Panel, Cap (Includes Insulation)				
	405-6037-02	1	HDKAJ				
	405-6037-03	1	HDKAH, HDKAK, HDKAJ with Hour Meter				
10			>Insulation, Cap				
	405-5757	1	Spec A				
	405-5875	1	Begin Spec D				
11	405-5083-01		%Assy Panel, Rail (Includes Panel and Insulation)				
12	405-5779	1	/*Insulation, Panel Rail				

- * - Parts Included in Insulation Kit
- + - Parts Included in Curb Panel Assembly.
- # - Parts Included in Engine Panel Assembly
- ^ - Parts Included in Top Panel Assembly
- @- Parts Included in Lifting Eye Access Panel.
- >- Parts Included in Cap Panel Assembly.
- %- Parts Included in Rail Panel Assembly

Housing (HDKAT, HDKAU, HDKAV)

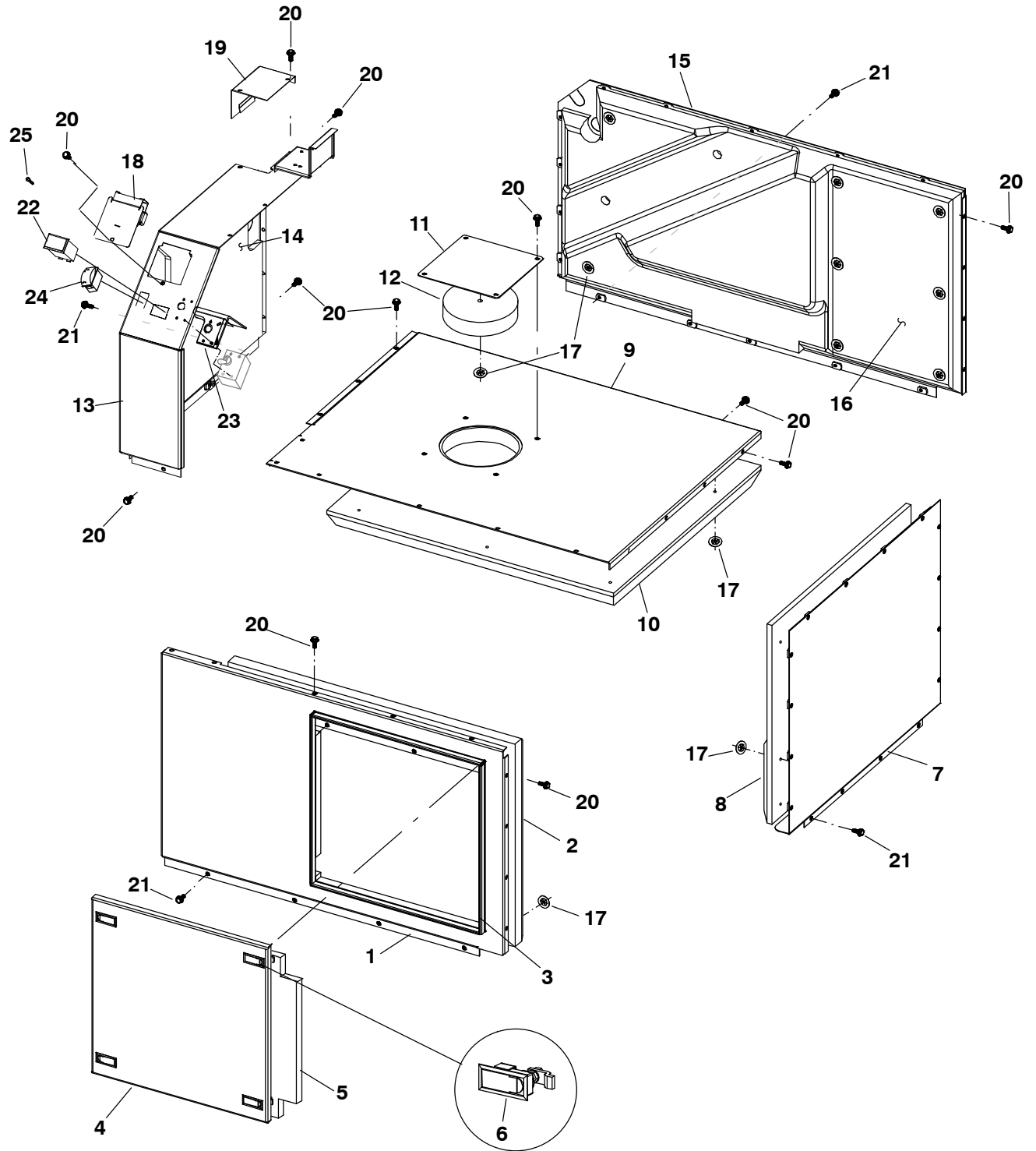

Housing (HDKAT, HDKAU, HDKAV)

REF NO.	PART NO.	QTY USED	PART DESCRIPTION	REF NO.	PART NO.	QTY USED	PART DESCRIPTION
1	405-5824-01	1	+Assy Panel, Curb (Includes Panel and Insulation)	17	518-0581	22	Nut, Push-On
2	405-5822-01	1	+Insulation, Panel Curb	18	405-5309-03	1	Cover, Radiator Fill Access
3	508-1118	1	+Edging, Trim	19	405-5380-05	1	Cover, AC Access
4	405-5823-01		*Assy Door, Access(Includes Panel and Insulation)	20	821-2096-02	34	Screw, Locking Flange (M6 x 1 x 12mm)
5	405-5822-02	1	*Insulation, Door Panel	21	821-2096-03	18	Screw, Locking Flange (M6 x 1 x 16mm)
6	406-0842	4	*Latch, Lift and Turn	22	302-2002	1	Hourmeter
7	405-5080-01	1	^Assy Panel, Engine(Includes Panel and Insulation)	23	320-1939-02	1	Guard, Circuit Breaker
8	405-5081	1	^Insulation, Engine Panel	24	308-1038	1	Rocker, Switch (Stop/Start)
9	405-5066-01	1	<Assy Panel, Top(Includes Panel and Insulation)	25	815-0550	4	Screw, Pan Head W/O Circuit Breaker Boot (6-32 x 3/8")
10	405-5762	1	<Insulation, Top Panel				
11	405-5575-01	1	>Assy Cover, Lifting Eye Access(Includes Cover and Insulation)				
12	405-5546	1	>Insulation, Access Cover				
13	405-6037-03	1	#Assy Panel, Cap(Includes Panel and Insulation)				
14	405-5875	1	#Insulation, Cap				
15	405-5083-01	1	~Assy Panel, Rail(Includes Panel and Insulation)				
16	405-5779	1	~Insulation, Panel Rail				

- + - Parts Included in Curb Panel Assembly
- * - Parts Included in Door Access Assembly
- ^ - Parts Included in Engine Panel Assembly
- <- Parts Included in Top Panel Assembly
- >- Parts Included in Lifting Eye Access Cover Assembly
- # - Parts Included in Cap Panel Assembly
- ~- Parts Included in Rail Panel Assembly

Generator

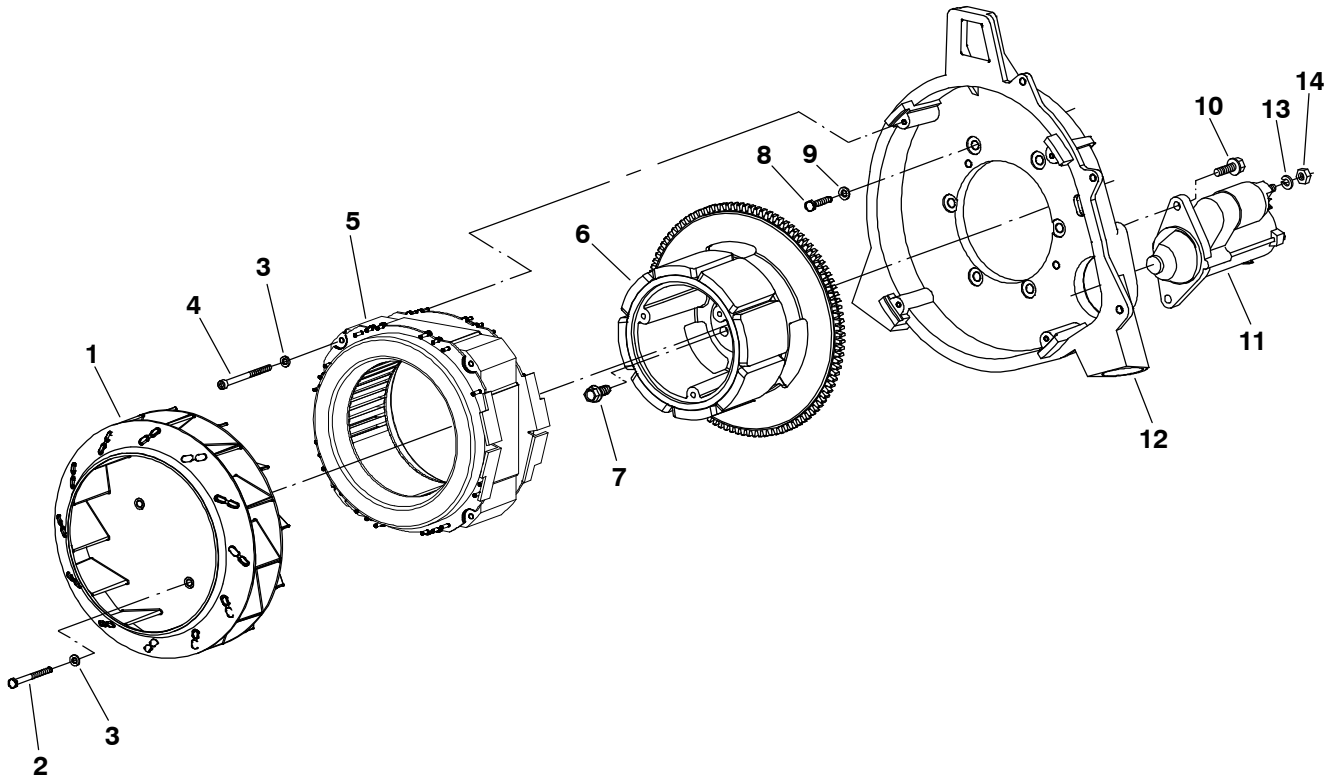

REF NO.	PART NO.	QTY USED	PART DESCRIPTION	REF NO.	PART NO.	QTY USED	PART DESCRIPTION
1			Fan, Generator HDKAH, HDKAJ, HDKAK				HDKAT, HDKAU, HDKAV Spec A-D (Magnet Marked with White Strip)
	205-0232	1	Spec A-G		201-3540	1	
	205-0302	1	Begin Spec H		201-3540-01	1	Begin Spec E
	205-0232	1	HDKAT, HDKAU, HDKAV Spec A-D	7	185-5587	5	Screw, Hex Head Cap
	205-0302	1	Begin Spec E	8	800-2058	6	Screw, Hex Head Cap (M8 X 1.25 X 25mm)
2	800-2044	3	Screw, Hex Head Cap (M6 x 1 x 70mm)	9	526-2100	6	Washer, Flat (M8)
3	526-2080	7	Washer, Flat (M6)	10	815-0781	2	Screw, Hex Washer Head (M8 x 1.25 x 30mm)
4	815-0936	4	Screw, Socket Head Cap (M6 x 1 x 100mm)	11	191-2200	1	Starter (See Separate Page for Components)
5	220-4484-01	1	* Stator	12	104-1890	1	Housing, Flywheel
6			Rotor Assy (Includes Ring Gear) HDKAH, HDKAJ, HDKAK	13	850-2008	1	Washer, Lock (M8)
	201-3540	1	Spec A-G (Magnet Marked with White Strip)	14	870-0557	1	Nut, Hex (M8 x 1.25)
	201-3540-01	1	Begin Spec H				

* - If Ordering 220-4484-01, You Will Need to Order the Complete Alternator A053K355.

Starter Components

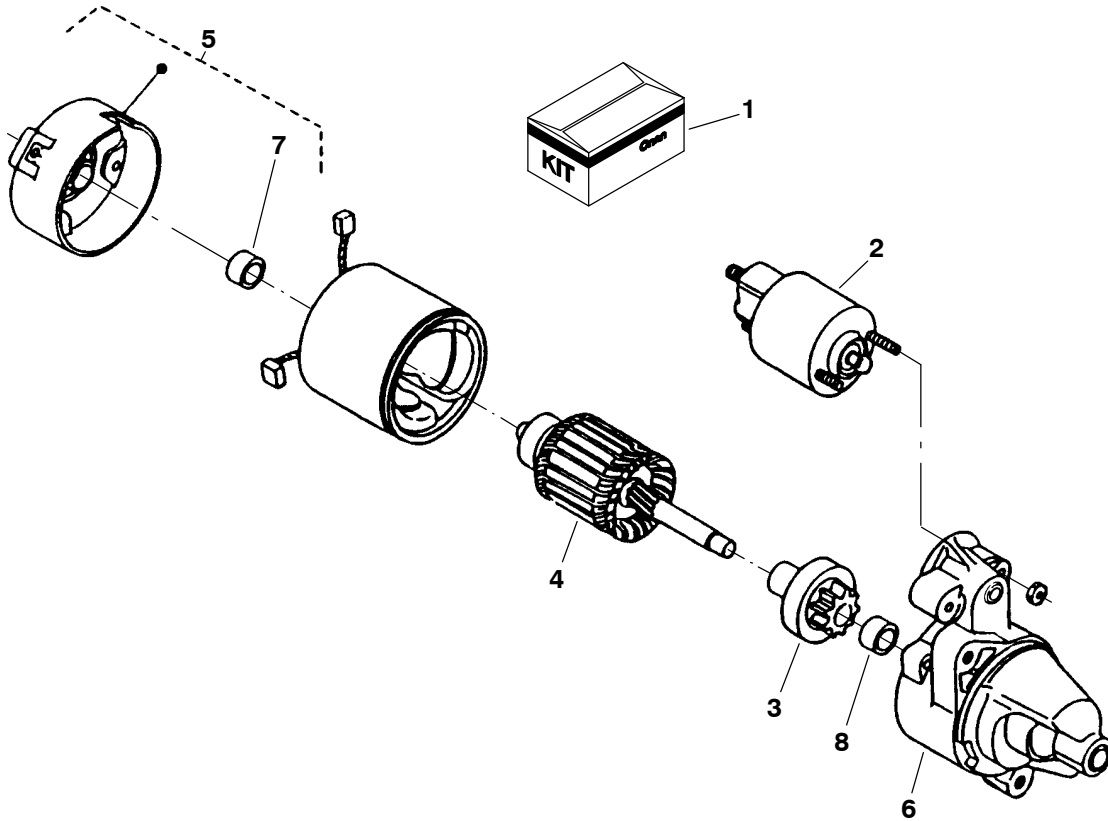

REF NO.	PART NO.	QTY USED	PART DESCRIPTION
	191-2200	1	Starter
1	191-2215	1	Kit, Starter Brush
2	191-2216	1	Switch
3	191-2217	1	Clutch
4	191-2218	1	Armature

REF NO.	PART NO.	QTY USED	PART DESCRIPTION
5	191-2219	1	Frame, Commutator End
6	191-2220	1	Housing
7	191-2221	1	Bearing, Commutator End
8	191-2222	1	Bearing, Pinion End

Inverter Mount

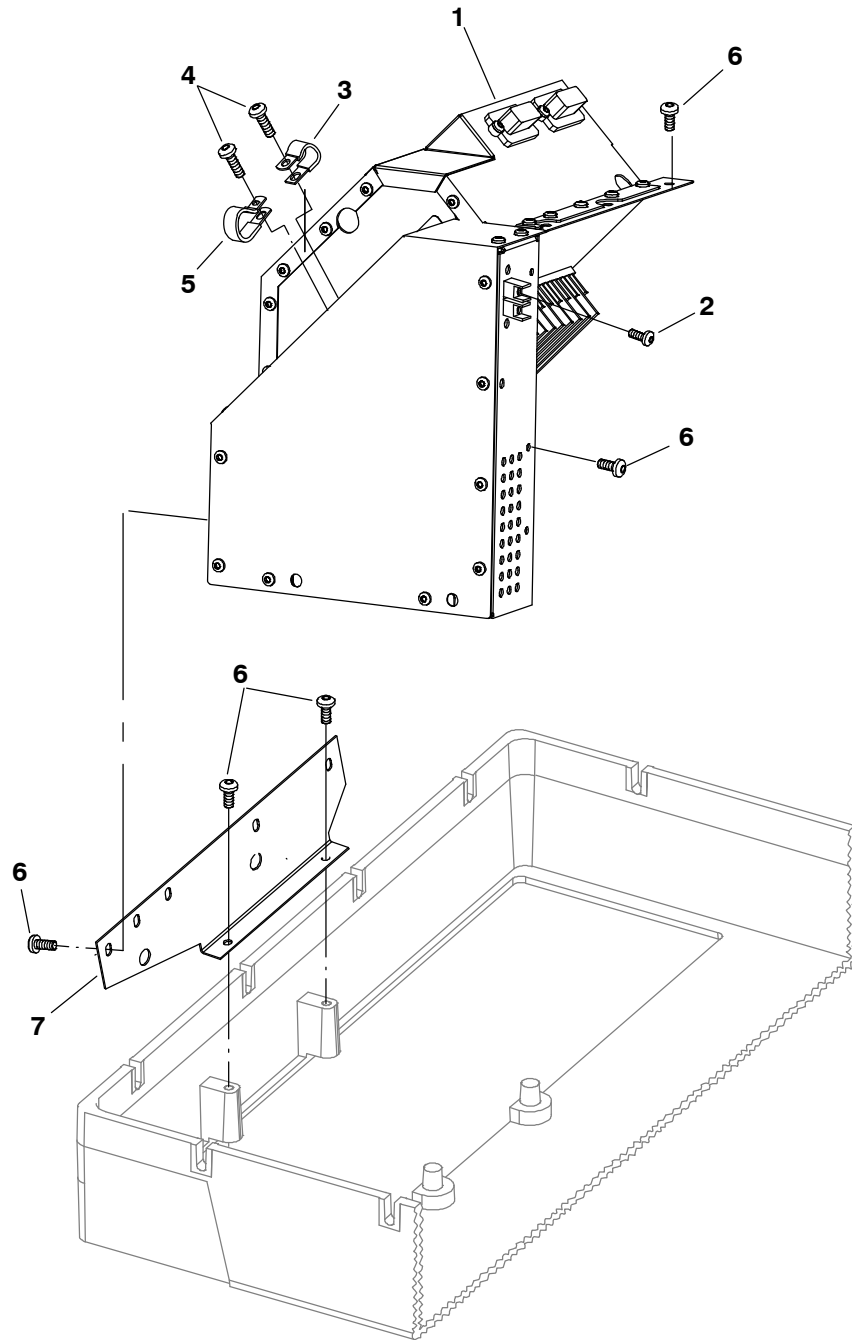

REF NO.	PART NO.	QTY USED	PART DESCRIPTION	REF NO.	PART NO.	QTY USED	PART DESCRIPTION
1	300-6058-02	1	Inverter	6	823-0003-05	11	Screw, Pan Head (M6 x 1 x 14mm)
2	815-0896-03	2	Screw, Pan Head Torx (8-32 x 3/8")	7	319-3033-02	1	Bracket, Inverter
3	518-0515	1	Clip, Loop	8	327-1461	1	Board, Control (Not Shown)
4	823-1002-04	2	Screw, Pan Head Machine (M6 x 1 x 14mm)				
5	332-1553	1	Clamp, Loop (1")				

Engine Harness

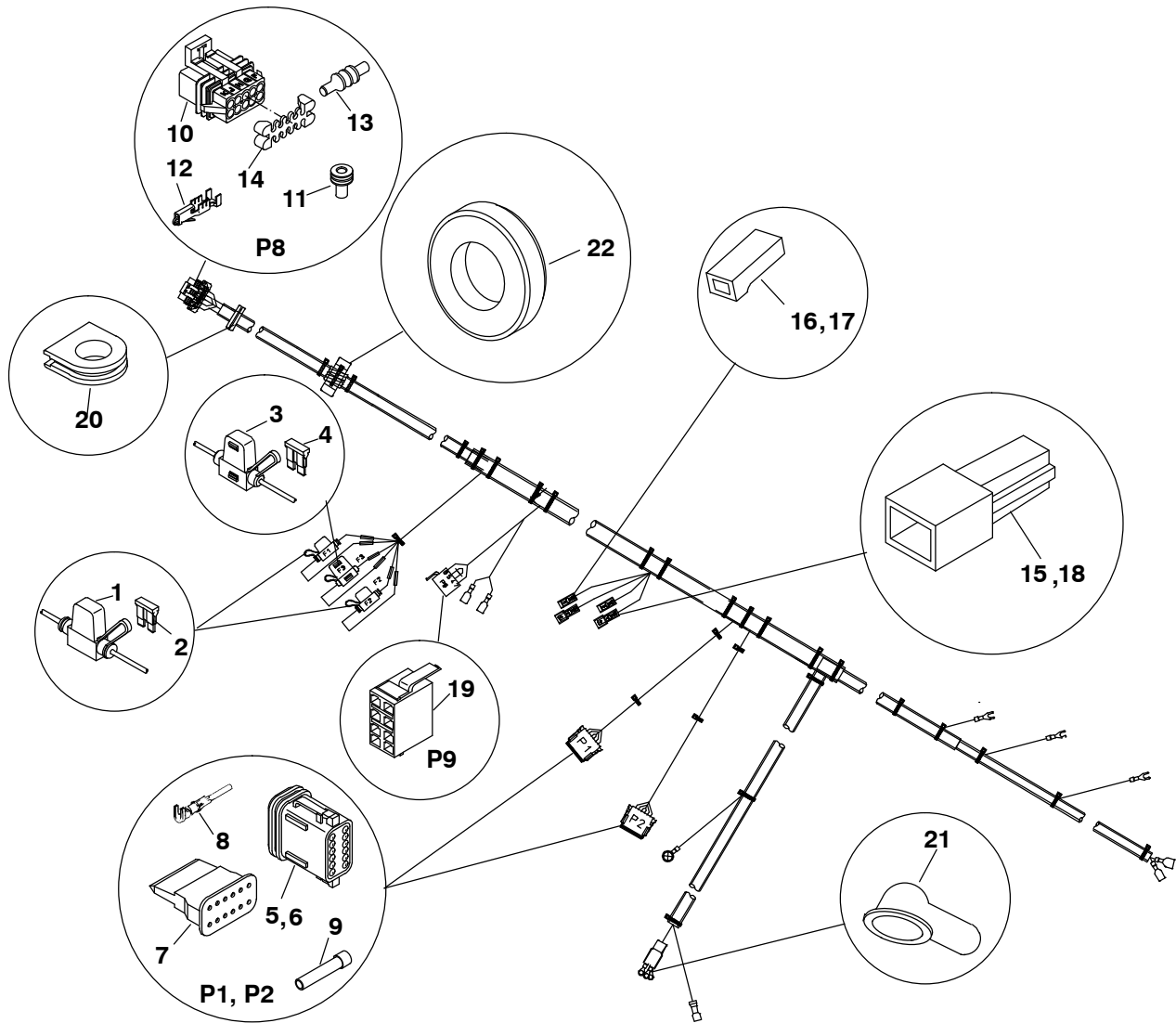

REF NO.	PART NO.	QTY USED	PART DESCRIPTION	REF NO.	PART NO.	QTY USED	PART DESCRIPTION
			*Harness, Engine	16	332-0819	1	Housing, Receptacle Terminal (Natural) (A1-J7)
	338-3416	1	Spec A-G	17	332-0819-02	1	Housing, Receptacle Terminal (Red) (A1-J5)
	338-3822	1	Begin Spec H	18	332-2298-01	1	Housing, Tab Terminal (Black) (A1-J8)
	338-3416	1	Spec A-D	19	308-1019	1	Connector, Switch (P9)
	338-3822	1	Begin Spec E	20	508-1105	1	Grommet
1	321-0322	2	Holder, Fuse (1-1/2") (F1, F2)	21	332-2112	1	Insulator, Terminal
2	321-0321-07	2	Fuse, Blue Blade (F1, F2) (15A)	22			Core
3	321-0349	1	Holder, Fuse (1") (F3)				HDKAH, HDKAJ, HDKAK
4	321-0307-08	1	Fuse, Natural Blade (F3) (25A)		315-0770	4	Spec A-G (Ferrite)
5	323-1582	1	Connector, Plug (12 Pin) (P1)		315-0821	1	Begin Spec H (Tape Wound)
6	323-1582-02	1	Connector, Plug (12 Pin) (P2)		315-0821	1	HDKAT, HDKAU, HDKAV
7	323-1583	2	Wedge, Plug (12 Pin) (P1, P2)		315-0770	4	Spec A-D (Ferrite)
8	323-1492	20	Terminal, Socket (P1, P2)				Begin Spec E (Tape Wound)
9	323-1591	4	Seal, Plug (P1, P2)				
10	323-1711	1	Connector, Plug (10 Pin) (P8)				
11	323-1708	9	Seal, Cable (P8)				
12	323-1709	9	Terminal, Socket (P8)				
13	323-1712	1	Plug, Cavity (P8)				
14	323-1719	1	Lock, Housing (P8)				
15	332-2298	1	Housing, Tab Terminal (A1-J6)				

* - See Also the Mounting Base Page for Hardware Included with this Harness.

AC Harness

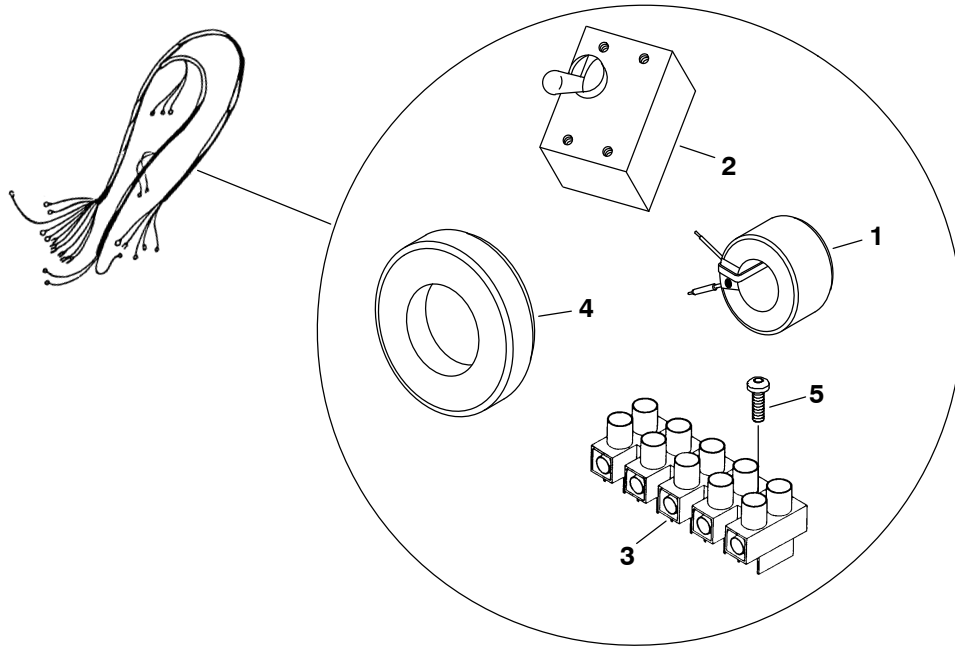

REF NO.	PART NO.	QTY USED	PART DESCRIPTION	REF NO.	PART NO.	QTY USED	PART DESCRIPTION
			Harness, AC Wiring HDKAH, HDKAJ, HDKAK Spec A-C	3			Block, AC Terminal HDKAH, HDKAJ, HDKAK Spec A-C
338-3418		1	W/Battery Charger	332-3384		1	Begin Spec D
338-3417		1	W/O Battery Charger	332-3531-04		1	HDKAT, HDKAU, HDKAV
			All Specs Except 11502	4			Core, Ferrite HDKAH, HDKAJ, HDKAK
338-3417-03		1	Spec 11502 Only	315-0770		4	Spec A-D
			Spec D-G	315-0821		1	Begin Spec E
338-3588-01		1	W/Battery Charger				HDKAT, HDKAU, HDKAV
			W/O Battery Charger	315-0770		4	Spec A
338-3587-01		1	All Specs Except 11502	315-0821		1	Begin Spec B
			Spec 11502 Only	5			Screw
338-3587-04		1	Begin Spec H	823-0002-08		2	HDKAH, HDKAJ, HDKAK Spec A Pan Head Torx (M4 x .7 x 25mm)
338-3823-01		1	W/Battery Charger	812-0070		2	Begin Spec D Round Head Machine (6-32 x 1-1/4")
			W/O Battery Charger	812-0070		2	HDKAT, HDKAU, HDKAV Round Head Machine (6-32 x 1-1/4")
338-3824-01		1	All Specs Except 11502				
338-3824-04		1	Spec 11502 Only				
			HDKAT, HDKAU, HDKAV				
338-3588-01			Spec A-D				
338-3823-01		1	Begin Spec E				
1	315-0760	1	Transformer				
2			Breaker, Circuit				
	320-2442-01	1	35A (All Specs Except 11502)				
	320-1875-04	1	30A (Spec 11502 Only)				

Battery Harness

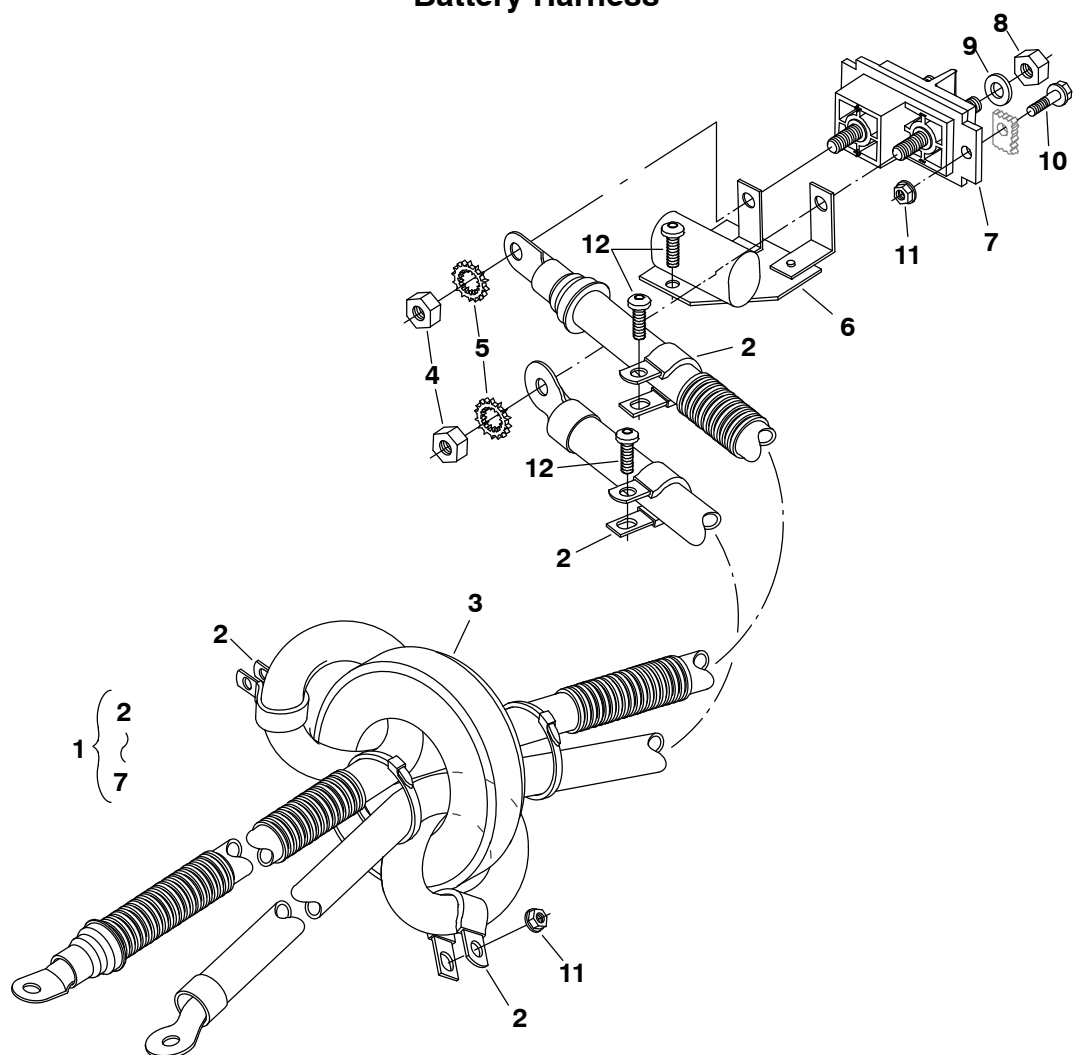

REF NO.	PART NO.	QTY USED	PART DESCRIPTION	REF NO.	PART NO.	QTY USED	PART DESCRIPTION
1			Harness, Battery (Includes Parts Marked *)	6	300-4884	1	*PCB Assy, Filter DC
	338-3422	1	Spec A-G	7	332-3408	1	*Block, Terminal
	338-3841	1	Begin Spec H	8	871-0025	2	Nut, Hex Brass (5/16-18)
	338-3422	1	Spec A-D	9	526-0054	2	Washer, Flat (5/16")
	338-3841	1	Begin Spec E	10	821-2096-03	2	Screw, Lock Flange (M6 x 1 x 20mm)
2	332-1554	4	*Clamp, Insulated Loop	11	870-2054	3	Nut, Lock Flange (M6 x 1)
3	315-0770	1	*Core, Ferrite (Not Included with Harness #338-3841)	12	823-0003-05	3	Screw, Pan Head (M6 x 1 x 14mm)
4	862-0015	2	*Nut, Hex (5/16-18)				
5	856-0008	2	*Washer, EIT Lock (5/16")				

* - Parts Included in Battery Harness.

Harnesses

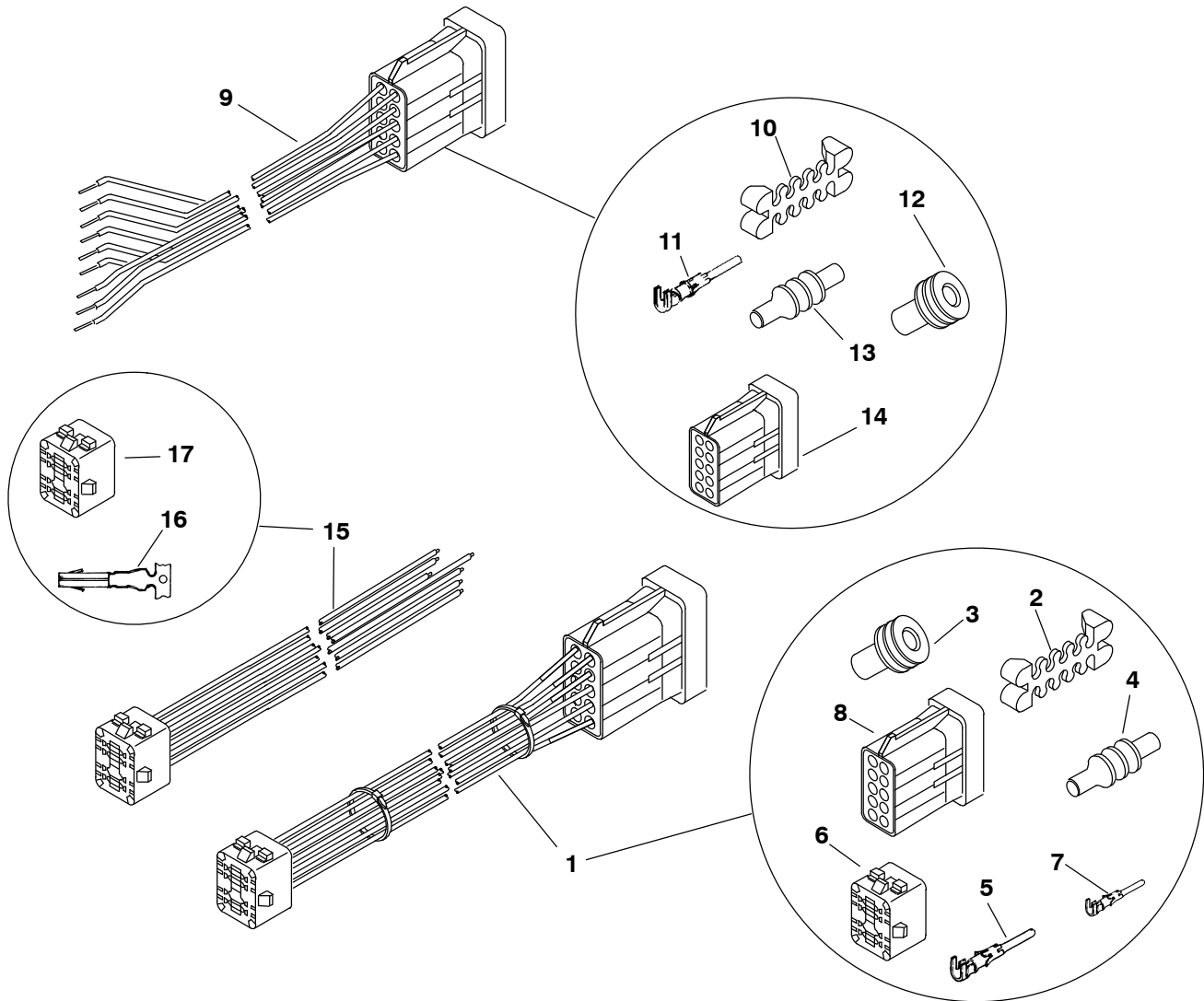

REF NO.	PART NO.	QTY USED	PART DESCRIPTION	REF NO.	PART NO.	QTY USED	PART DESCRIPTION
1			Harness, Extension (Reaches From DC Control Harness to Remote Panel) (Includes Parts Marked +)	10	323-1719	1	°Housing, Lock
	338-3490-01	1	10 Feet	11	323-1707	8	°Pin, Contact
	338-3490-02	1	30 Feet	12	323-1708	8	°Seal, Cable
2	323-1719	1	+Housing, Lock	13	323-1712	2	°Plug, Cavity
3	323-1708	8	+Seal, Cable	14	323-1710	1	°Connector, Receptacle (10 Pin)
4	323-1712	2	+Plug, Cavity	15	338-3573	1	Harness, Customer Interface Pigtail 6" (Reaches From Remote Panel to Customer Interface) (Includes Sockets and Cap)
5	323-1200	AR	+Socket, Contact	16	323-1200	8	Socket, Contact
6	323-1325	1	+Cap, Connector	17	323-1325	1	Cap, Connector
7	323-1707	AR	+Pin, Contact				
8	323-1710	1	+Connector, Receptacle (10 Pin)				
9	300-4947	1	Harness, Remote Connector (Customer Interface Pigtail 6") (Reaches From DC Control Harness to Customer Interface) (Includes Parts Marked °)				

+ - Parts Included in Extension Harness.
 ° - Parts Included in Remote Connector Harness.

Remote Switch Panel

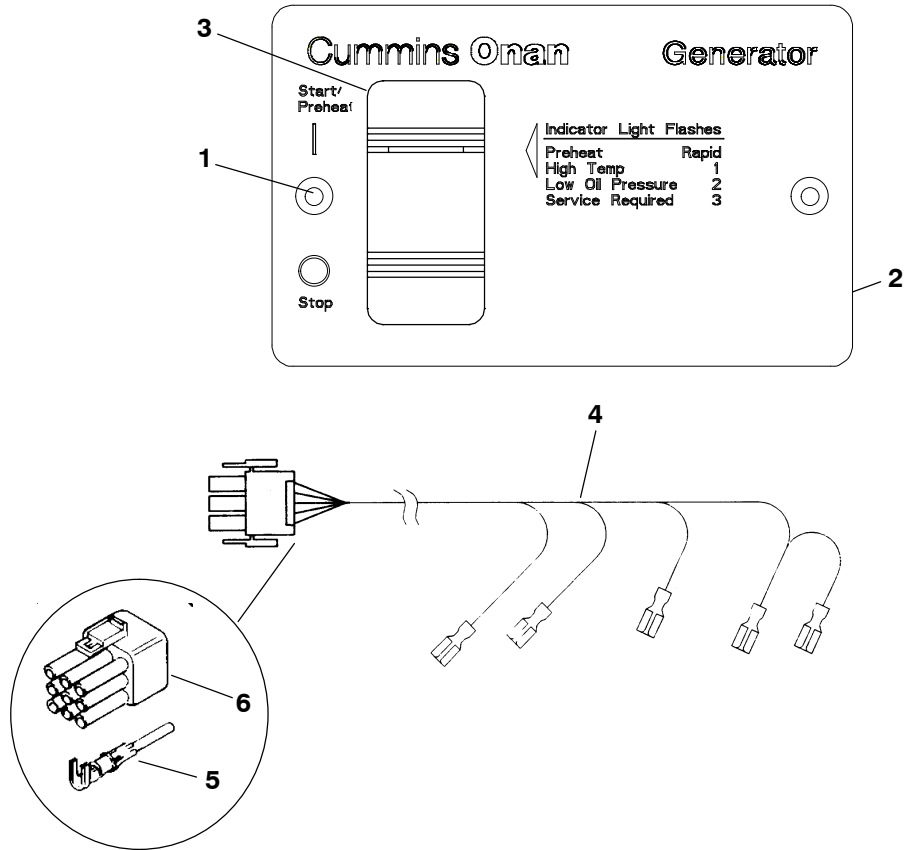

REF NO.	PART NO.	QTY USED	PART DESCRIPTION	REF NO.	PART NO.	QTY USED	PART DESCRIPTION
	300-4942	1	Kit, Remote Switch Panel	4	338-3512	1	Harness, Remote Panel (Includes Pins and Plug)
1	815-0910	2	Screw, Wood Mounting (#6 x 1)	5	323-1199	4	Pin, Contact
2	319-6988-01	1	Panel, Printed	6	323-1291	1	Plug (9 Pin)
3	308-1062	1	Switch, Rocker				

Remote Switch/Hourmeter Panel

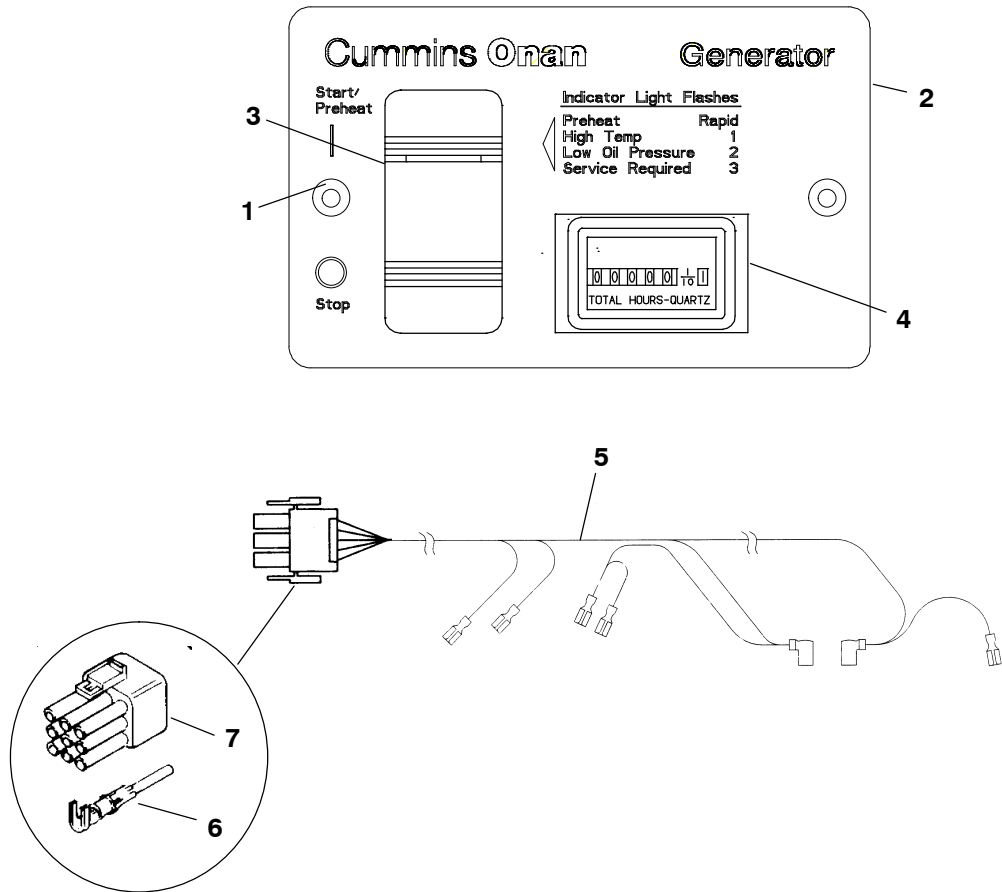

REF NO.	PART NO.	QTY USED	PART DESCRIPTION	REF NO.	PART NO.	QTY USED	PART DESCRIPTION
	300-4943	1	Kit, Switch/Hourmeter Remote Panel	4	302-2002	1	Hourmeter
1	815-0910	2	Screw, Wood Mounting (#6 x 1)	5	338-3475	1	Harness, Remote Panel (Includes Pins and Plug)
2	319-6988-02	1	Panel, Printed	6	323-1199	4	Pin, Contact
3	308-1062	1	Switch, Rocker	7	323-1291	1	Plug (9 Pin)

Remote Switch/Voltmeter Panel

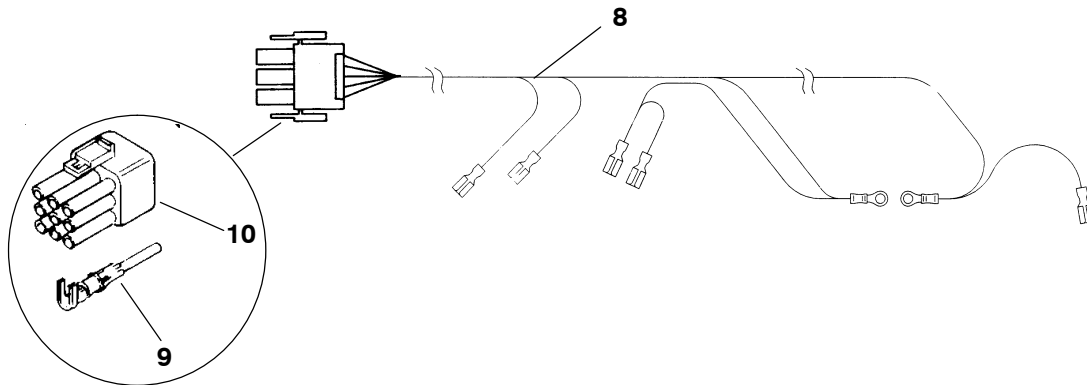
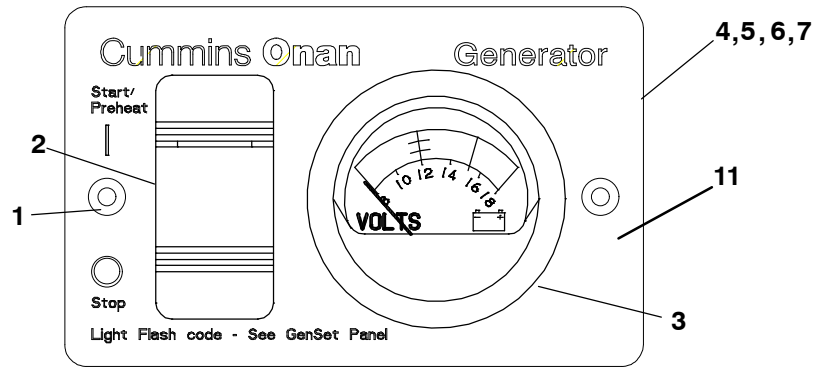

REF NO.	PART NO.	QTY USED	PART DESCRIPTION	REF NO.	PART NO.	QTY USED	PART DESCRIPTION
	300-4944	1	Kit, Remote Switch/Voltmeter Panel	7	850-0030	2	Washer, Lock (#10)
1	815-0910	2	Screw, Wood Mounting (#6 x 1)	8	338-3509	1	Harness, Remote Panel (Includes Pins and Plug)
2	308-1062	1	Switch, Rocker	9	323-1199	4	Pin, Contact
3	302-1641	1	Meter, Voltage	10	323-1291	1	Plug (9 Pin)
4	526-0409	2	Washer, Nylon (3/16")	11	319-6989-03	1	Panel, Printed
5	526-0049	4	Washer, Flat (#10)				
6	871-0010	4	Nut, Hex Brass Machine (#10-32)				

Remote Gauge Panel

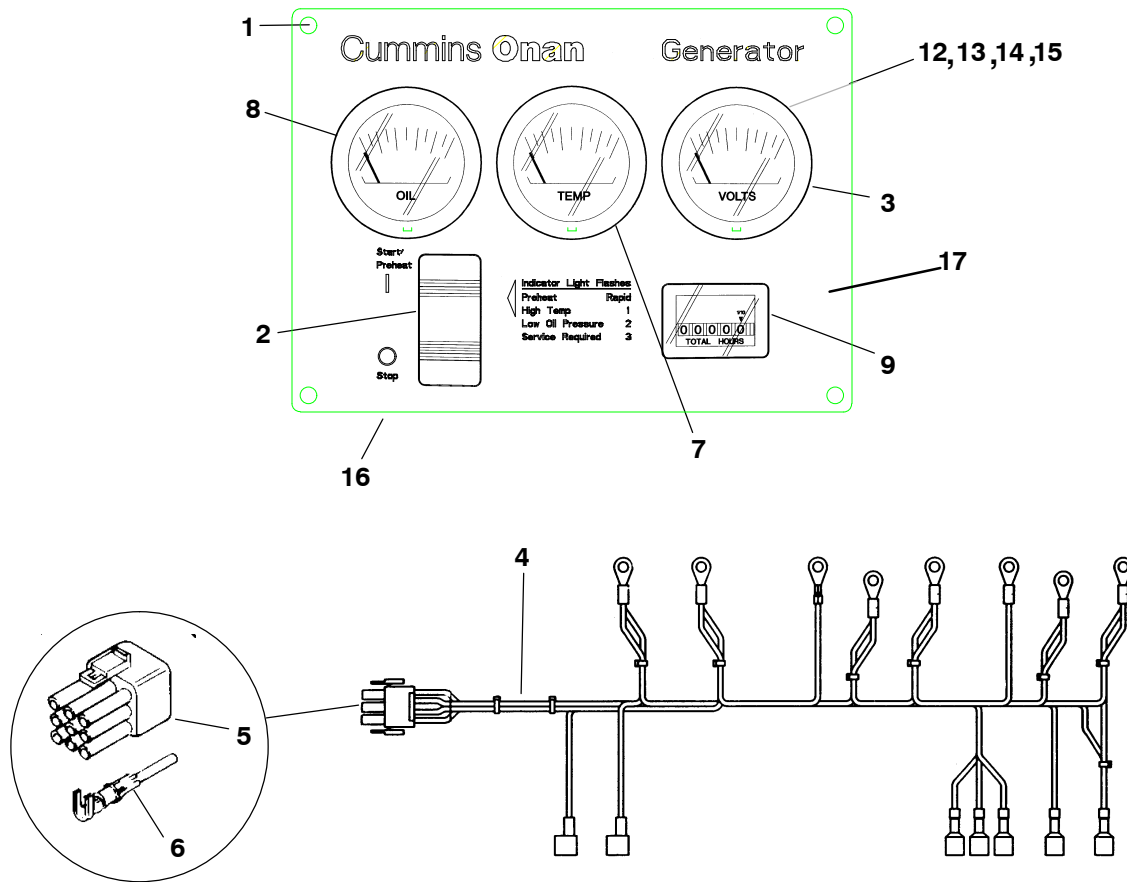

REF NO.	PART NO.	QTY USED	PART DESCRIPTION	REF NO.	PART NO.	QTY USED	PART DESCRIPTION
	300-5027	1	Kit, Remote Gauge Panel	7	193-0351	1	Gauge, Water Temperature
1	808-0023	4	Screw, Pan Head Sheet Metal Mounting (#8 x 1/2")	8	193-0352	1	Gauge, Oil Pressure
2	308-1062	1	Switch, Rocker (SPDT)	9	302-2002	1	Hourmeter
3	302-1641	1	Meter, Voltage	12	526-0409	8	Washer, Nylon (3/16")
4	338-3637	1	Harness, Remote Panel (Includes Plug and Pins)	13	526-0049	16	Washer, Flat (#10)
5	323-1291	1	Plug (9 Pin)	14	871-0010	16	Nut, Hex Brass Machine (#10-32)
6	323-1199	8	Pin, Contact	15	850-0030	8	Washer, Lock (#10)
				16	319-4508	1	Panel, w /Decal
				17	319-6993	1	Panel Assy, Printed

Labels

REF NO.	PART NO.	QTY USED	PART DESCRIPTION	REF NO.	PART NO.	QTY USED	PART DESCRIPTION
	98-7485-07	1	Label, Blank Wiring Harness		541-0531	1	Kit, Commercial Remote Air Cleaner (Includes Parts Marked +)
			Label, Control Panel (2 Pole, W/Hourmeter)				
	98-7125-01	1	35A		718-1035	4	+Screw, Hex Head Cap (M8 x 16mm)
	98-7125-05	1	30A				
	98-7368	1	Label, GenVerter		870-2055	2	+Nut, Lock Flange
			Label, Model Ident		503-2030	2	+Hose, Air Cleaner
			RV		140-3065	1	+Tube, Adapter
	98-6876-01	1	7.5 kW		140-3098	1	+Sleeve, Air Intake
	98-6876-02	1	8.0 kW		503-1895-07	1	+Hose, Air Cleaner
	98-7369	2	Commercial, 7.5 kW		503-1895-08	1	+Hose, Air Cleaner
	98-6780-01	1	Label, Remote Panel/Switch		503-0429	4	+Clamp, Hose
	98-6780-02	1	Label, Remote Panel/		503-1774	1	+Clamp, "J" Support
			Hourmeter		403-2213	1	+Spacer, Mounting Pad
	98-7351-03	1	Label, Remote Panel/Voltmeter		800-0055-01	1	+Screw, Hex Head Cap
	98-7466	1	Label, Rear Control (M14, M13, M12, GND)		508-0051	1	+Grommet
	98-7465-03	1	Label, Control Face (Onan Quiet Diesel)		821-2096-04	2	+Screw, Lock Flange (M6 x 1 x 20mm)
					850-2008	2	+Washer, Lock (M8)
	98-7244	1	Package, Label (Includes Parts Marked *)		140-3099-02	1	+Bracket, Air Cleaner
					140-3100-02	2	+Shim, Bracket
	98-7196	1	*Label, Cool/Oil Fill		526-2080	2	+Washer, Flat (M6)
	98-6877	1	*Label, Coolant Level		541-0530	1	Kit, Aux Commercial Fuel Pump (Includes Parts Marked #)
	98-6878	1	*Label, Fuel Attachment				
	98-6476	1	*Label, Ground		149-2547	1	#Pump, Aux Fuel
	98-7482	1	*Label, Hose Kit		338-3580	1	#Harness, Fuel Pump
	98-7197	1	*Label, Patent		332-2947	2	#Connector, Splice
	98-7199	1	*Label, Service Info		323-1608	1	#Housing, Connector
	98-7127	1	*Label, Warning (Hazardous Voltage)		323-1607	2	#Contact, Socket
					323-1576	2	#Seal, Cable
	98-7130	1	*Label, Warning (Overheat)				
	98-7128	2	*Label, Warning (Voltage/Rotating Parts/Operation Service Risk)				
	98-7131	1	*Label, Warning (Voltage/Rotating Fan)				
	98-7497-02	1	Label, Warning Install				
	98-7494-01	1	Label, Warning Install				

* - Parts Included in Label Package.

+ - Parts Included in Commercial Remote Air Cleaner Kit.

- Parts Included in Aux Commercial Fuel Pump Kit.

THIS PAGE IS INTENDED TO BE BLANK

Numerical Index

<u>Part No.</u>	<u>Page</u>	<u>Part No.</u>	<u>Page</u>	<u>Part No.</u>	<u>Page</u>	<u>Part No.</u>	<u>Page</u>
0404-0376-03,	47	130-4392,	35	155-3110,	43	185-2124,	30
098-6476,	61	130-4450-02,	35	181-9000,	29	185-2163,	17 , 19
098-6780-01,	61	130-4462,	35	181-9005,	38	185-2173,	14
098-6780-02,	61	130-4655,	45	181-9075,	19	185-2180,	15 , 16
098-6876-01,	61	130-4689,	36	181-9159,	12	185-2188,	20
098-6876-02,	61	130-6904,	27	181-9162,	11	185-2233,	9
098-6877,	61	130-6936,	36	181-9165,	9	185-2234,	9
098-6878,	61	130-7902,	35	181-9168,	22	185-2238,	27
098-7125-01,	61	134-5063,	33	181-9169,	14	185-2283,	15
098-7125-05,	61	134-5126,	33	181-9177,	22	185-2284,	15 , 16 , 21 , 22 , 26 , 28
098-7127,	61	140-2536-05,	33	181-9183,	9	185-2309,	30
098-7128,	61	140-2897,	33	181-9185,	27	185-2338,	15 , 16
098-7130,	61	140-2898,	33	181-9196,	27	185-2345,	21
098-7131,	61	140-2956,	33	181-9200,	38	185-2349,	28
098-7196,	61	140-2961-02,	33	181-9201,	19	185-2351,	24 , 25
098-7197,	61	140-3065,	61	181-9202,	22	185-2353,	11 , 17 , 19
098-7199,	61	140-3098,	61	181-9203,	14	185-2357,	17 , 19
098-7244,	61	140-3099-02,	61	181-9210,	38	185-2374,	30
098-7351-03,	61	140-3100-02,	61	181-9211,	30	185-2380,	12 , 19
098-7368,	61	140-3231,	33	181-9213,	30	185-2384,	29
098-7369,	61	140-3232,	33	181-9226,	43	185-2385,	21 , 22
098-7465-03,	61	140-3233,	33	181-9227,	38	185-2386,	17 , 24 , 25
098-7466,	61	149-2513,	32	181-9247,	20	185-2387,	12
098-7482,	61	149-2547,	61	181-9249,	29	185-2388,	27
098-7485-07,	61	149-2580,	32	181-9251,	25	185-2389,	17 , 19 , 30 , 37 , 38 , 40 , 41
098-7497-02,	61	149-2584,	32	181-9252,	29	185-2390,	13
100-3707,	9	149-2585-02,	32	181-9253,	29	185-2393,	14
100-3957,	9	149-2790,	32	184-0054,	14	185-2395,	30
104-1890,	50	150-2630,	26	185-2016,	11	185-2396,	37
112-0304,	11	150-2639,	26	185-2022,	11	185-2398,	37 , 38
122-0833,	30	150-2641,	26	185-2023,	11	185-2411,	20
123-2051,	37	150-2643-S0,	26	185-2028,	11	185-2412,	9
123-2120,	37	150-2724,	26	185-2029,	11	185-2413,	20
123-2264,	29	150-2872,	16	185-2030,	11	185-2414,	20
123-2268,	29	154-2800,	43	185-2031,	11	185-2559,	13 , 31
123-2300,	41	154-2862,	43	185-2033,	11	185-2572,	39
123-2303,	29	154-3018,	43	185-2094,	9	185-2870,	16
130-4321,	35	155-2424,	43	185-2095,	9 , 20	185-3078,	37
130-4322,	35	155-2610,	43	185-2105,	30	185-4255,	24 , 30
130-4391,	35	155-2982,	43	185-2115,	9		

Numerical Index

<u>Part No.</u>	<u>Page</u>	<u>Part No.</u>	<u>Page</u>	<u>Part No.</u>	<u>Page</u>	<u>Part No.</u>	<u>Page</u>
185-5162,	29	185-5393,	23	185-5500,	20	185-5558,	12
185-5337,	21 , 22	185-5394,	23	185-5501,	20	185-5560,	12
185-5348,	24 , 25	185-5395,	23	185-5502,	20	185-5561,	12
185-5350,	11	185-5396,	23	185-5503,	20	185-5562,	12
185-5351,	11	185-5397,	23	185-5505,	30	185-5563,	12
185-5356,	11	185-5398,	23	185-5506,	30	185-5564,	12
185-5357,	11	185-5399,	23	185-5507,	30	185-5565,	12
185-5358,	11	185-5400,	23	185-5509,	30	185-5566,	11
185-5360,	11	185-5401,	23	185-5510,	30	185-5568,	11
185-5361,	11	185-5402,	23	185-5511,	30	185-5569,	11
185-5363,	23	185-5403,	23	185-5512,	30	185-5570,	11
185-5364,	23	185-5404,	23	185-5513,	30	185-5571,	11
185-5365,	23	185-5405,	23	185-5515,	13	185-5572,	11
185-5366,	23	185-5406,	23	185-5516,	13	185-5573,	11
185-5367,	23	185-5407,	28	185-5517,	13	185-5575,	11
185-5368,	23	185-5410,	30	185-5519,	13	185-5576,	11
185-5369,	23	185-5412,	9	185-5520,	28	185-5577,	11
185-5370,	23	185-5413,	9	185-5521,	28	185-5578,	11
185-5371,	23	185-5414,	9	185-5522,	28	185-5579,	11
185-5372,	23	185-5415,	9	185-5523,	28	185-5580,	11
185-5373,	23	185-5416,	9	185-5524,	28	185-5581,	11
185-5374,	23	185-5421,	21 , 22	185-5525,	28	185-5583,	11
185-5375,	23	185-5425,	19	185-5529,	28	185-5584,	11
185-5376,	23	185-5433,	31	185-5534,	43	185-5587,	50
185-5377,	23	185-5434,	31	185-5536,	43	185-5612,	21 , 22
185-5378,	23	185-5437,	13	185-5537,	24 , 25	185-5613,	22
185-5379,	23	185-5438,	13	185-5538,	24 , 25	185-5615,	21 , 22
185-5380,	23	185-5458,	27	185-5539,	24 , 25	185-5616,	23
185-5381,	23	185-5482,	9	185-5540,	24 , 25	185-5617,	23
185-5382,	23	185-5483,	9	185-5541,	24 , 25	185-5618,	23
185-5383,	23	185-5484,	9	185-5542,	24	185-5619,	23
185-5384,	23	185-5485,	9	185-5545,	24	185-5621,	23
185-5385,	23	185-5486,	9	185-5546,	24	185-5622,	23
185-5386,	23	185-5487,	9	185-5547,	24	185-5623,	17 , 19
185-5387,	23	185-5488,	9	185-5550,	24 , 25	185-5624,	17 , 19
185-5388,	23	185-5489,	9	185-5551,	24 , 25	185-5625,	17 , 19
185-5389,	23	185-5490,	9	185-5552,	24 , 25	185-5626,	18 , 19
185-5390,	23	185-5491,	9	185-5553,	24 , 25	185-5629,	17 , 19
185-5391,	23	185-5492,	9	185-5554,	12	185-5630,	17 , 19
185-5392,	23	185-5496,	37 , 38	185-5555,	12	185-5631,	17 , 19

Numerical Index

<u>Part No.</u>	<u>Page</u>	<u>Part No.</u>	<u>Page</u>	<u>Part No.</u>	<u>Page</u>	<u>Part No.</u>	<u>Page</u>
185-5632,	17 , 19	185-5714,	31	185-6707,	18	185-7267,	26
185-5633,	17 , 19	185-5715,	31	185-6711,	30	185-7382,	30
185-5634,	17 , 19	185-5716,	31	185-6738,	21 , 22 , 23	185-7383,	13
185-5635,	17 , 19	185-5717,	31	185-6739,	17 , 19	185-7385,	12
185-5638,	18	185-5719,	27 , 29	185-6759,	17 , 19 , 24 , 30	185-7386,	11
185-5639,	18	185-5722,	27	185-6762,	20	185-7389,	21
185-5640,	18	185-5723,	27	185-6791,	43	185-7390,	21
185-5641,	18	185-5727,	30	185-6818,	37	185-7395,	25
185-5642,	18	185-5741,	30	185-6825,	23	185-7397,	21
185-5643,	18	185-5742,	30	185-6845,	17 , 19	185-7407,	11
185-5644,	18	185-5743,	30	185-6846,	37	185-7415,	11
185-5645,	18	185-5744,	30	185-6852,	43	185-7421,	38
185-5646,	18	185-5745,	30	185-6853,	43	185-7426,	29
185-5647,	18	185-5746,	30	185-6883,	17 , 19	191-2200,	50 , 51
185-5648,	18	185-5747,	28	185-6888,	19	191-2215,	51
185-5649,	18	185-5793,	25	185-6919,	19	191-2216,	51
185-5650,	18	185-5798,	17 , 19	185-6931,	15 , 16	191-2217,	51
185-5652,	18	185-5800,	30	185-6937,	17 , 18	191-2218,	51
185-5653,	18	185-5805,	20	185-6945,	14	191-2219,	51
185-5654,	18	185-5807,	28	185-6948,	21	191-2221,	51
185-5655,	18	185-5808,	13	185-6956,	37 , 38	191-2222,	51
185-5658,	18	185-5817,	18	185-6999,	14	191-2228,	45
185-5659,	18	185-5818,	18	185-7004,	21	193-0318,	27
185-5660,	18 , 19	185-5819,	18	185-7069,	27 , 30	193-0351,	60
185-5661,	18 , 19	185-5820,	18 , 19	185-7070,	30	193-0352,	60
185-5662,	18 , 19	185-5823,	21 , 22	185-7071,	28	201-3540,	50
185-5663,	18 , 19	185-5829,	43	185-7072,	13	201-3540-01,	50
185-5679,	15 , 16	185-5831,	40 , 41	185-7073,	13	205-0232,	50
185-5680,	15 , 16	185-5832,	40 , 41	185-7074,	12	205-0302,	50
185-5681,	15 , 16	185-5833,	40 , 41	185-7075,	12	220-4484-01,	50
185-5682,	15 , 16	185-5924,	12	185-7076,	11	300-4884,	55
185-5685,	15	185-5966,	14	185-7077,	17	300-4942,	57
185-5696,	14	185-5985,	21 , 22	185-7078,	15	300-4943,	58
185-5701,	14	185-6120,	20	185-7080,	26	300-4944,	59
185-5702,	14	185-6257,	30	185-7082,	21 , 22	300-4947,	56
185-5703,	14	185-6580,	17	185-7083,	39	300-5027,	60
185-5707,	39	185-6669,	27	185-7085,	24 , 25	300-6058-02,	52
185-5709,	39	185-6704,	9	185-7086,	24 , 25	302-1641,	59 , 60
185-5712,	31	185-6705,	11	185-7087,	40 , 41	302-2002,	47 , 49 , 58 , 60
185-5713,	31	185-6706,	17				

Numerical Index

<u>Part No.</u>	<u>Page</u>	<u>Part No.</u>	<u>Page</u>	<u>Part No.</u>	<u>Page</u>	<u>Part No.</u>	<u>Page</u>
305-0952-02,	45	323-1712,	53 , 56	402-0680-01,	45	502-0313,	32
308-1019,	53	323-1719,	53 , 56	402-0687-01,	43	502-1296-02,	32
308-1038,	47 , 49	327-1461,	52	402-0688-02,	43	502-1367-01,	35
308-1062,	57 , 58 , 59 , 60	332-0819,	53	402-0695-02,	43	502-1529,	35
315-0760,	54	332-0819-02,	53	403-2213,	61	503-0429,	33 , 61
315-0770,	53 , 54 , 55	332-1356,	33	403-3847-04,	45	503-1137,	35
315-0793,	45	332-1553,	36 , 52	403-3859,	37	503-1774,	61
315-0821,	53 , 54	332-1554,	32 , 55	403-3860,	32	503-1895-07,	61
319-3033-02,	52	332-2112,	53	403-3861,	45	503-1895-08,	61
319-4508,	60	332-2298,	53	403-3863-02,	32	503-1920,	35
319-6988-01,	57	332-2298-01,	53	405-5066-01,	49	503-1921,	35
319-6988-02,	58	332-2898,	37	405-5077-01,	47	503-1922,	35
319-6989-03,	59	332-2947,	61	405-5080-01,	47 , 49	503-1923,	35
319-6993,	60	332-3384,	54	405-5081,	47 , 49	503-1951-09,	32
320-1875-04,	54	332-3408,	55	405-5083-01,	47 , 49	503-1951-12,	32 , 35
320-1939-02,	47 , 49	332-3531-04,	54	405-5086,	36	503-1951-35,	35
320-2442-01,	54	337-2845,	45	405-5308,	36	503-1951-46,	37
321-0307-08,	53	337-2953,	45	405-5309-03,	47 , 49	503-1954,	35
321-0321-07,	53	338-3416,	53	405-5380-05,	47 , 49	503-1959,	35
321-0322,	53	338-3417,	54	405-5546,	47 , 49	503-1970-02,	35
321-0349,	53	338-3417-03,	54	405-5575-01,	47 , 49	503-1979,	33
323-1199,	57 , 58 , 59 , 60	338-3418,	54	405-5757,	47	503-1985,	33
323-1200,	56	338-3422,	55	405-5759,	47	503-2030,	61
323-1291,	57 , 58 , 59 , 60	338-3475,	58	405-5762,	47 , 49	503-2052,	32
323-1325,	56	338-3490-01,	56	405-5779,	47 , 49	505-0266,	43
323-1492,	53	338-3490-02,	56	405-5780,	47	508-0051,	61
323-1576,	61	338-3509,	59	405-5787,	43	508-1105,	53
323-1582,	53	338-3512,	57	405-5818-S0,	45	508-1118,	49
323-1582-02,	53	338-3573,	56	405-5822-01,	49	508-1255,	11
323-1583,	53	338-3580,	61	405-5822-02,	49	509-0329,	35 , 37
323-1591,	53	338-3587-01,	54	405-5823-01,	49	509-0380,	11
323-1607,	61	338-3587-04,	54	405-5824-01,	49	510-0163,	17
323-1608,	61	338-3588-01,	54	405-5875,	47 , 49	510-0184,	26
323-1707,	56	338-3637,	60	405-6037-02,	47	510-0229,	19
323-1708,	53 , 56	338-3822,	53	405-6037-03,	47 , 49	511-0235,	39
323-1709,	53	338-3823-01,	54	406-0612,	45	517-0273,	32
323-1710,	56	338-3824-01,	54	406-0842,	49	518-0515,	52
323-1711,	53	338-3824-04,	54	501-0927,	22	518-0581,	36 , 47 , 49
		338-3841,	55	501-0932,	32	518-0672,	26
		402-0673-02,	45	502-0153,	37	526-0049,	59 , 60

Numerical Index

<u>Part No.</u>	<u>Page</u>	<u>Part No.</u>	<u>Page</u>	<u>Part No.</u>	<u>Page</u>	<u>Part No.</u>	<u>Page</u>
526-0054,	55	821-2096-04,	61				
526-0115,	43	823-0002-08,	54				
526-0409,	59 , 60	823-0003-02,	33 , 43				
526-2080,	24 , 50 , 61	823-0003-03,	45				
526-2083,	37	823-0003-05,	52 , 55				
526-2100,	50	823-1002-03,	33 , 45				
541-0530,	61	823-1002-04,	33 , 45 , 52				
541-0531,	61						
718-1035,	61	850-0030,	59 , 60				
725-1027,	26	850-2006,	26				
725-1050,	43	850-2008,	43 , 45 , 50 , 61				
740-1002,	26	854-0028,	32				
800-0030,	45	856-0006,	45				
800-0055-01,	61	856-0008,	45 , 55				
800-0310-21,	43	862-0015,	45 , 55				
800-0603-01,	33	865-0029,	33				
800-2044,	50	868-0007,	32				
800-2058,	50	870-0257,	32				
800-6330,	29	870-0540-03,	33				
800-6372,	25	870-0542,	36				
802-2506,	26	870-0557,	43 , 50				
808-0023,	60	870-2054,	32 , 35 , 55				
812-0070,	54	870-2055,	61				
815-0550,	49	871-0010,	59 , 60				
815-0550-01,	47	871-0025,	55				
815-0753,	32 , 36	895-0297,	43				
815-0781,	50	898-1196-33,	32				
815-0829-05,	45	A053K355,	50				
815-0861,	45						
815-0877,	26						
815-0896-03,	52						
815-0908,	45						
815-0910,	57 , 58 , 59						
815-0936,	50						
818-0226-01,	36						
821-2032,	37						
821-2035,	35						
821-2096-02,	35 , 47 , 49						
821-2096-03,	36 , 47 , 49 , 55						

THIS PAGE IS INTENDED TO BE BLANK

power.cummins.com

Copyright © 2019 Cummins Inc. All rights reserved.

Cummins, Onan, and the "C" logo are registered trademarks of Cummins Inc. and its subsidiaries.

Other company, product, or service names may be trademarks or service marks of others.

Specifications are subject to change without notice.

