

Instruction Sheet

A051D263 (Issue 4)

7-2017

Installation Instructions for Load Management Kit A051C329

1 Introduction

Read these instructions completely and become familiar with safety warnings, cautions and procedures before starting the installation.

The information contained within is based on information available at the time of going to print. In line with Cummins policy of continuous development and improvement, information may change at any time without notice. The users should therefore make sure that before commencing any work, they have the latest information available.

The latest version of this instruction sheet is available on QuickServe Online (<https://quickserve.cummins.com>).

2 Safety Precautions

2.1 General Safety Precautions

WARNING

Hot Pressurized Liquid

Contact with hot liquid can cause severe burns.

Do not open the pressure cap while the engine is running. Let the engine cool down before removing the cap. Turn the cap slowly and do not open it fully until the pressure has been relieved.

WARNING

Moving Parts

Moving parts can cause severe personal injury.

Use extreme caution around moving parts. All guards must be properly fastened to prevent unintended contact.

WARNING

Toxic Hazard

Used engine oils have been identified by some state and federal agencies to cause cancer or reproductive toxicity.

Do not ingest, breathe the fumes, or contact used oil when checking or changing engine oil. Wear protective gloves and face guard.

⚠ WARNING

Toxic Hazard

Ethylene glycol, used as an engine coolant, is toxic to humans and animals.

Wear appropriate PPE. Clean up coolant spills and dispose of used coolant in accordance with local environmental regulations.

⚠ WARNING

Electrical Generating Equipment

Incorrect operation can cause severe personal injury or death.

Do not operate equipment when fatigued, or after consuming any alcohol or drug.

⚠ WARNING

Toxic Gases

Substances in exhaust gases have been identified by some state and federal agencies to cause cancer or reproductive toxicity.

Do not breathe in or come into contact with exhaust gases.

⚠ WARNING

Combustible Liquid

Ignition of combustible liquids is a fire or explosion hazard which can cause severe burns or death.

Do not store fuel, cleaners, oil, etc., near the generator set.

⚠ WARNING

High Noise Level

Generator sets in operation emit noise, which can cause hearing damage.

Wear appropriate ear protection at all times.

⚠ WARNING

Hot Surfaces

Contact with hot surfaces can cause severe burns.

The unit is to be installed so that the risk of hot surface contact by people is minimized. Wear appropriate PPE when working on hot equipment and avoid contact with hot surfaces.

⚠ WARNING

Electrical Generating Equipment

Incorrect operation and maintenance can result in severe personal injury or death

Make sure that only suitably trained and experienced service personnel perform electrical and/or mechanical service.

⚠ WARNING

Automated Machinery

Accidental or remote starting of the generator set can cause severe personal injury or death. Isolate all auxiliary supplies and use an insulated wrench to disconnect the starting battery cables (negative [-] first).

⚠ WARNING

Fire Hazard

Materials drawn into the generator set are a fire hazard. Fire can cause severe burns or death. Keep the generator set and the surrounding area clean and free from obstructions.

⚠ WARNING

Fire Hazard

Materials drawn into the generator set are a fire hazard. Fire can cause severe burns or death. Make sure the generator set is mounted in a manner to prevent combustible materials from accumulating under the unit.

⚠ WARNING

Fire Hazard

Accumulated grease and oil are a fire hazard. Fire can cause severe burns or death. Keep the generator set and the surrounding area clean and free from obstructions. Repair oil leaks promptly.

⚠ WARNING

Incorrect service or replacement of parts can result in severe personal injury or death, and/or equipment damage. Service personnel must be trained and experienced to perform electrical and mechanical service.

NOTICE

Keep multi-type ABC fire extinguishers close by. Class A fires involve ordinary combustible materials such as wood and cloth. Class B fires involve combustible and flammable liquid fuels and gaseous fuels. Class C fires involve live electrical equipment. (Refer to NFPA No. 10 in the applicable region.)

NOTICE

Before performing maintenance and service procedures on enclosed generator sets, make sure the service access doors are secured open.

NOTICE

Stepping on the generator set can cause parts to bend or break, leading to electrical shorts, or to fuel, coolant, or exhaust leaks. Do not step on the generator set when entering or leaving the generator set room.

2.2 Generator Set Safety Code

Before operating the generator set, read the manuals and become familiar with them and the equipment. Safe and efficient operation can be achieved only if the equipment is properly operated and maintained. Many accidents are caused by failure to follow fundamental rules and precautions.

WARNING

Electrical Generating Equipment

Incorrect operation and maintenance can result in severe personal injury or death.

Read and follow all Safety Precautions, Warnings, and Cautions throughout this manual and the documentation supplied with the generator set.

2.3 Electrical Shocks and Arc Flashes Can Cause Severe Personal Injury or Death

WARNING

Electric Shock Hazard

Voltages and currents present an electrical shock hazard that can cause severe burns or death.

Contact with exposed energized circuits with potentials of 50 Volts AC or 75 Volts DC or higher can cause electrical shock and electrical arc flash. Refer to standard NFPA 70E or equivalent safety standards in corresponding regions for details of the dangers involved and for the safety requirements.

Guidelines to follow when working on de-energized electrical systems:

- Use proper PPE. Do not wear jewelry and make sure that any conductive items are removed from pockets as these items can fall into equipment and the resulting short circuit can cause shock or burning. Refer to standard NFPA 70E for PPE standards.
- De-energize and lockout/tagout electrical systems prior to working on them. Lockout/Tagout is intended to prevent injury due to unexpected start-up of equipment or the release of stored energy.
- De-energize and lockout/tagout all circuits and devices before removing any protective shields or making any measurements on electrical equipment.
- Follow all applicable regional electrical and safety codes.

In summary:

- Do not tamper with or bypass interlocks unless you are authorized to do so.
- Understand and assess the risks - use proper PPE.
- Make sure that an accompanying person who can undertake a rescue is nearby.

3 Instruction

3.1 Installation of Load Management Kit A051C329

This instruction sheet describes the installation of load management kit A051C329 on generator set models GSBA, GSBB, GSBC, C13N6H, C17N6H, and C20N6H. Read these instructions completely and become familiar with safety warnings, cautions, and installation procedure before starting.

1. Make sure the generator set is shut down and disabled:
 - a. Place the generator set's Run/Off/Auto switch in the Off position and allow the generator set to thoroughly cool to the touch.

 WARNING
<p><i>Combustible Gases</i> <i>Ignition of explosive battery gases can cause severe personal injury. Do not smoke or cause any spark, arc, or flame while servicing batteries. Be sure to wear the appropriate PPE, including goggles, a face shield, and protective gloves.</i></p>

- b. Turn off and disconnect the battery charger from the AC source before disconnecting the battery cables.
 - c. Disconnect the negative (-) cable from the battery and secure it from contacting the battery terminals to prevent accidental starting.
 - d. Disconnect the positive (+) cable from the battery.

2. Mount the relay box:

The relay box must be mounted to an indoor wall using the appropriate fasteners and in compliance with all local codes. Follow the mounting instructions and see the diagram below for installation dimensions. Make sure that the wall where the relay will be mounted is suitable to hold the weight and size of the relay box firmly.

- a. Make sure that the location has no wires or plumbing, gas, or exhaust lines running behind the wall.
 - b. Make sure that the anchorage fasteners used to bolt the relay to the wall are strong enough to withstand the relay box weight and its vibration during operation.
 - c. Remove the cover from the relay box.
 - d. Hold the box in position and mark the mounting-hole locations.

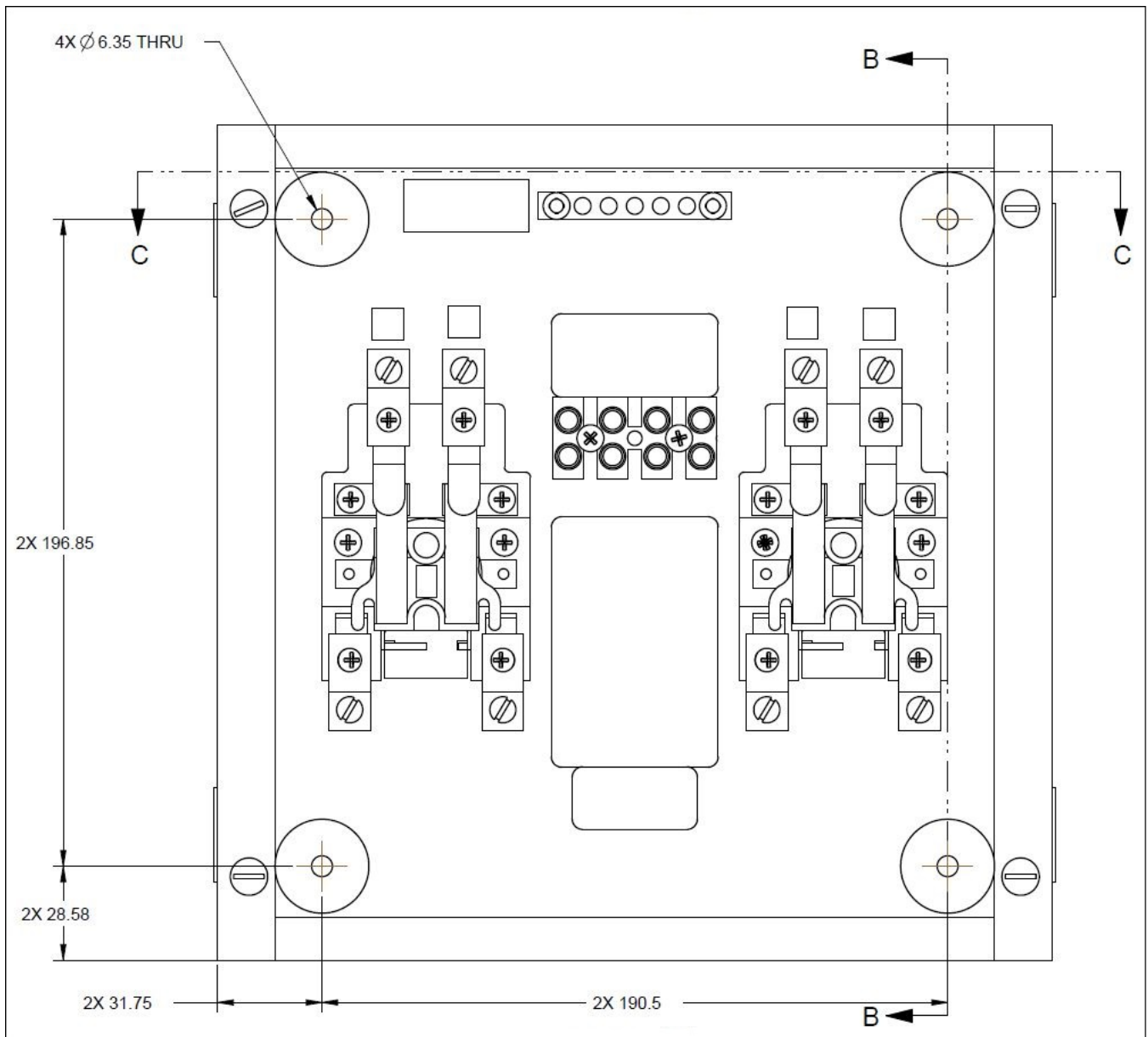

FIGURE 1. OUTLINE DRAWING WITH MOUNTING HOLE DIMENSIONS (A051C329)

- e. Drill holes and install the box with the appropriate fasteners.

NOTICE

Use four 1/4 inch bolts or other suitable fasteners for wall mounting.

3. Wire the relay:

NOTICE

Make sure that only trained and experienced service personnel perform electrical and/or mechanical service, in compliance with state and local codes and regulations.

a. *Models GSBA/GSBB/GSBC only:*

- i. Identify the correct control wires for Load Control 1 and Load Control 2, which are located in the plug and play harness that was used to connect the generator set to the transfer switch.
- ii. Using 18 AWG wire for the following connections:
 - A. Connect the signal wire (P7-7) to the "12VDC" terminal of relay 1 in the load shed device.
 - B. Connect the signal wire (P7-8) to the "12VDC" terminal of relay 2 in the load shed device.
 - C. Connect the Battery Negative (Common) or wire (P7-4) to the "COM" terminals of relays 1 and 2. See the figure below.

NOTICE

If only one load needs to be controlled, use only one relay. If there are two loads that need to be controlled, use two relays.

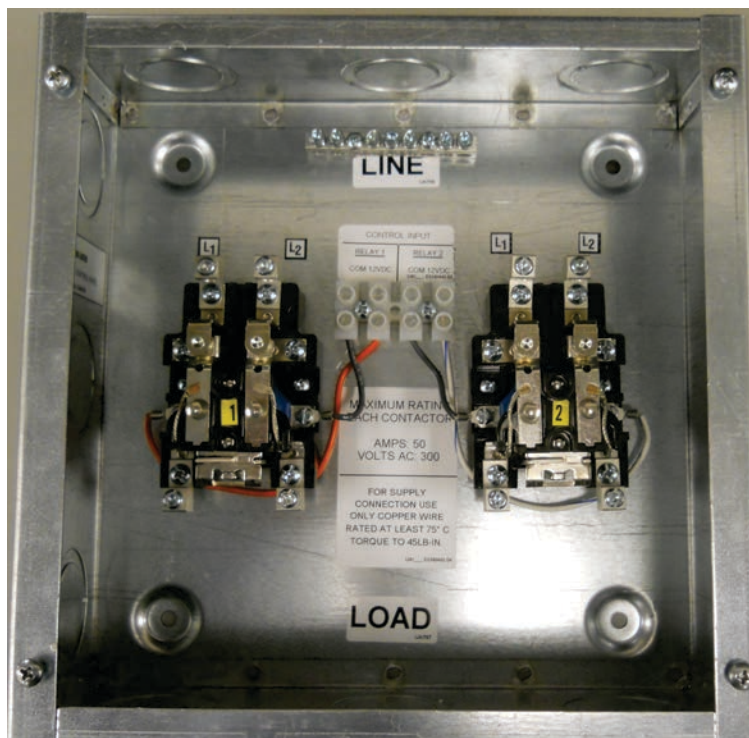

FIGURE 2. CONTACTOR BOX

b. *Models C13N6H/C17N6H/C20N6H only:*

- i. Identify the correct terminal block connectors (Wagos) for Load Control 1, Load Control 2, and Ground on the generator set, which are grouped with other customer DC terminal block connectors.

TABLE 1. CONNECTOR LABELS (MODELS C13N6H/C17N6H/C20N6H)

Connector	Label
Load Control 1	TB1-Load Control 1
Load Control 2	TB2-Load Control 2
Load Control 3	TB3-Load Control 3
Load Control 4	TB4-Load Control 4
Ground	TB7-GROUND

- ii. Using 18 AWG wire for the following connections:
- A. Connect a wire from the Load Control 1 connector to the "12VDC" terminal of relay 1 in the load shed device.
 - B. Connect a wire from the Load Control 2 connector to the "12VDC" terminal of relay 2 in the load shed device.
 - C. Connect wires from the Ground connector to the "COM" terminals of relays 1 and 2. See [Figure 2](#).

NOTICE
If only one load needs to be controlled, use only one relay. If there are two loads that need to be controlled, use two relays.

- c. Turn off the main service entrance circuit breaker or pull the fuse.
- d. Remove the load center cover.
- e. Make sure the load center is de-energized and associated connections are dead.
- f. Using the appropriately sized wire for the load and circuit breaker size, make the following connections (see the diagrams below for both 120 VAC and 240 VAC loads):

⚠ WARNING
<i>Electric Shock Hazard</i> <i>Voltages and currents present an electrical shock hazard that can cause severe burns or death.</i> <i>Contact with exposed energized circuits with potentials of 50 Volts AC or 75 Volts DC or higher can cause electrical shock and electrical arc flash. Refer to standard NFPA 70E or equivalent safety standards in corresponding regions for details of the dangers involved and for the safety requirements.</i>

⚠ CAUTION
<i>The following steps should only be performed by qualified personnel. Make sure that all applicable state and local codes and regulations have been followed.</i>

NOTICE
These relays are rated for 50A maximum; the lugs are sized for AWG #4-14, copper or aluminum.

- Connect the output of the circuit breaker or fuse to the LINE side of the relay.

- Connect the LOAD side of the relay to the outgoing load conductors in the load center or fuse box.

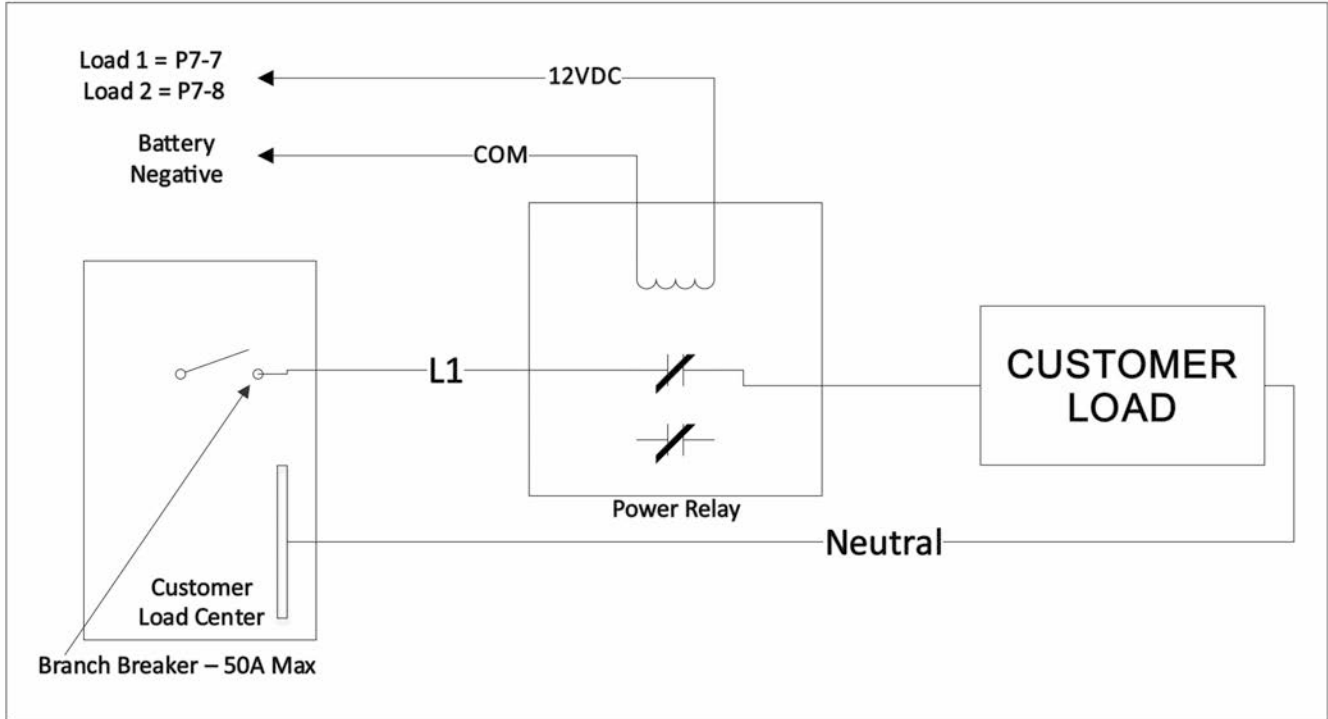

FIGURE 3. INTERCONNECTION DIAGRAM (120 VAC) (MODELS GSBA/GSBB/GSBC)

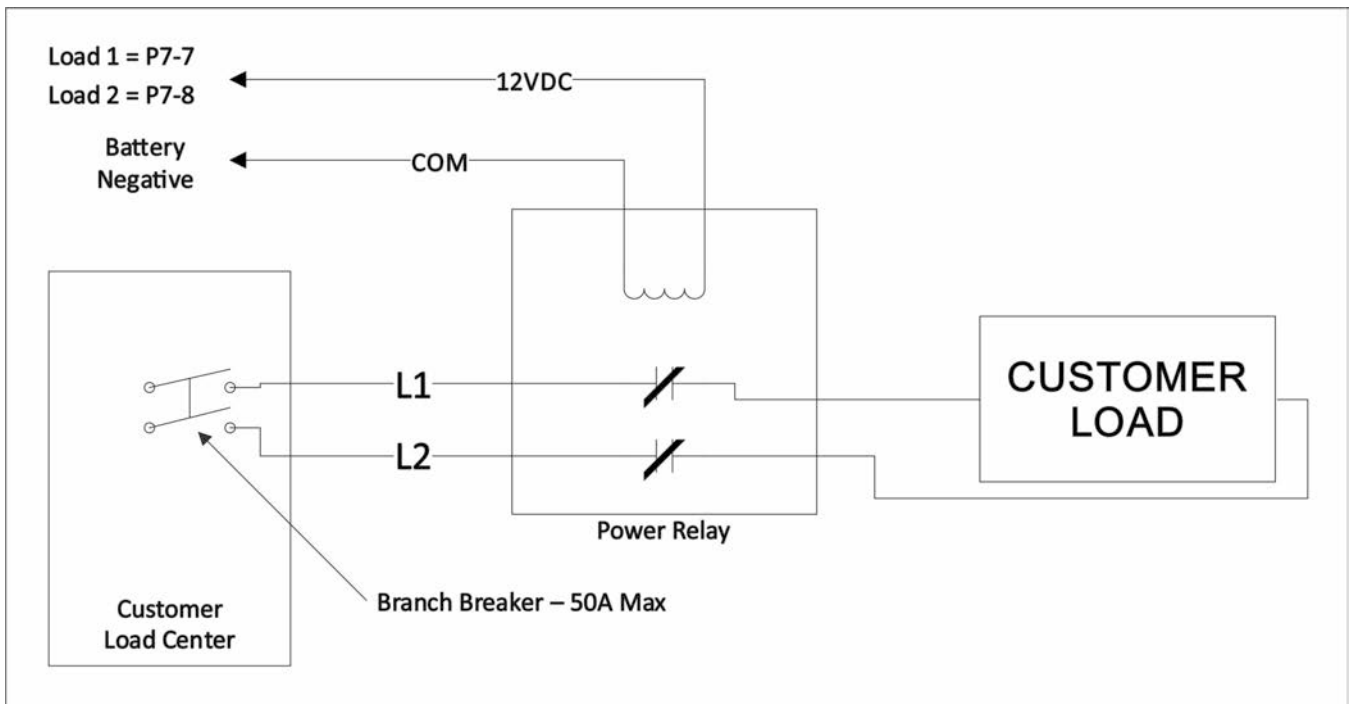

FIGURE 4. INTERCONNECTION DIAGRAM (240 VAC) (MODELS GSBA/GSBB/GSBC)

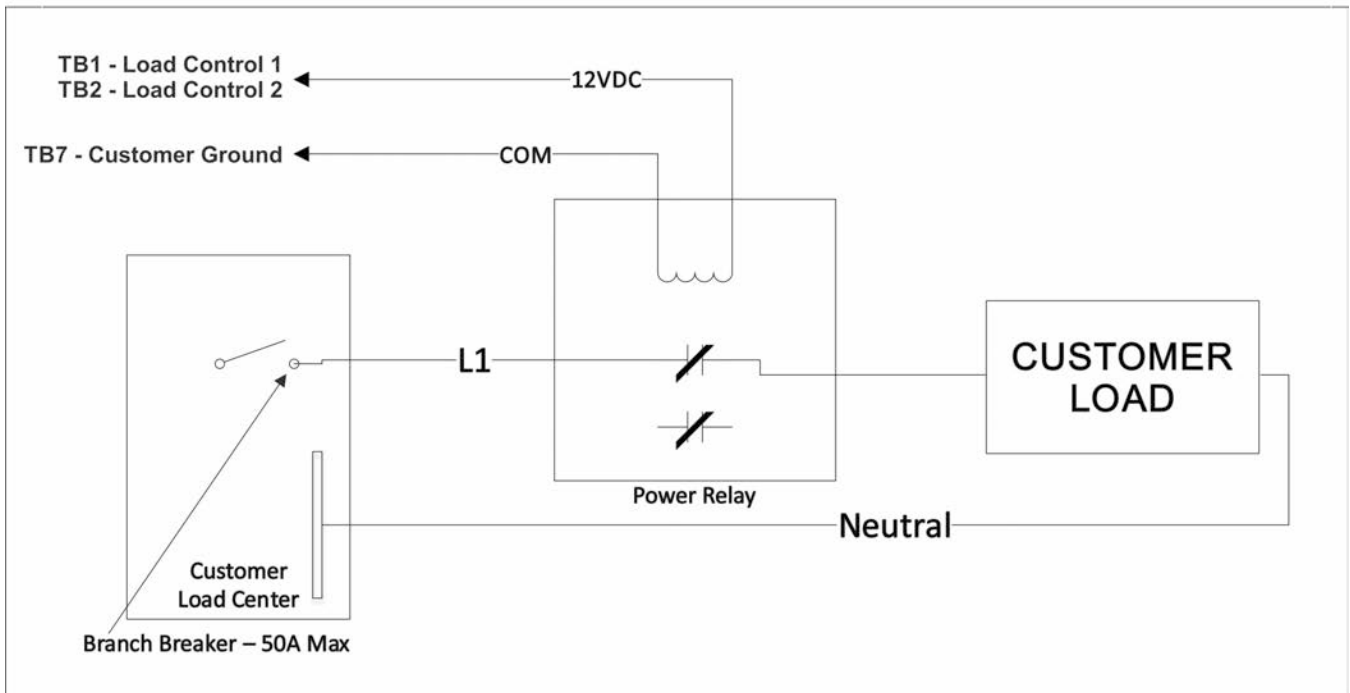

FIGURE 5. INTERCONNECTION DIAGRAM (120 VAC) (MODELS C13N6H/C17N6H/C20N6H)

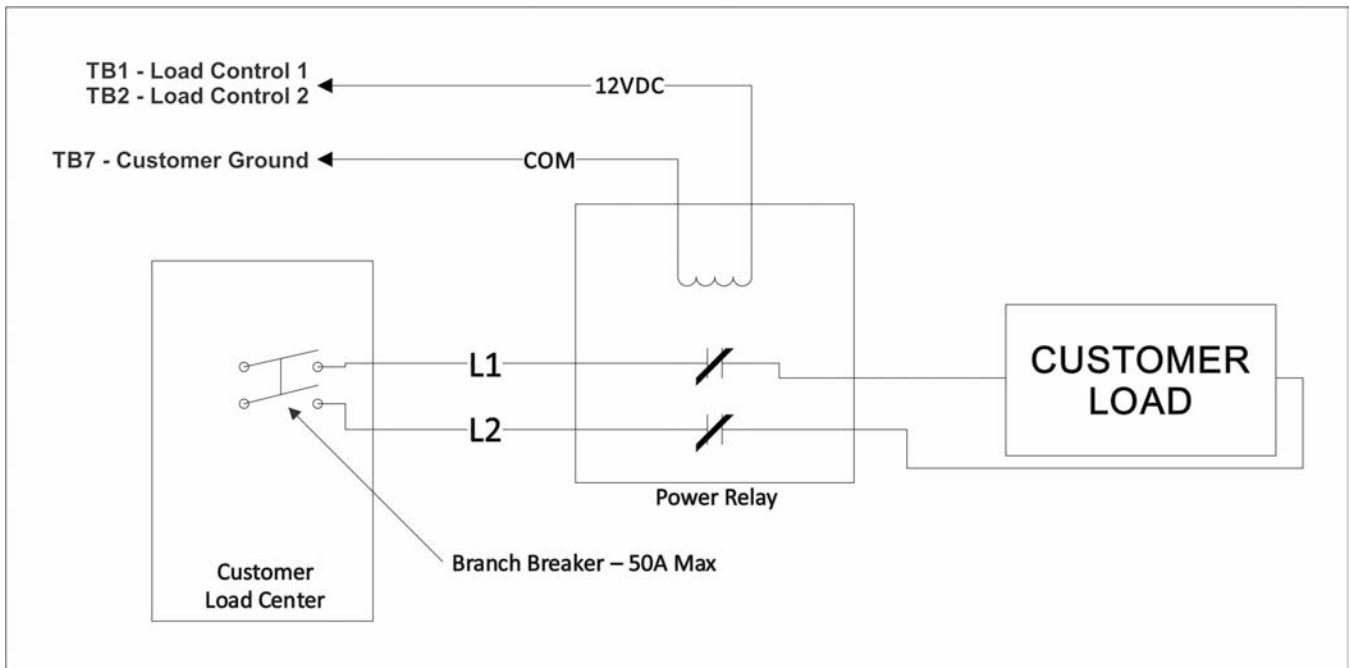

FIGURE 6. INTERCONNECTION DIAGRAM (240 VAC) (MODELS C13N6H/C17N6H/C20N6H)

4. Reconnect the cables and battery charger:
 - a. Reconnect the engine battery cables, positive (+) cable first.
 - b. Reconnect the battery charger to its AC power source.

NOTICE

For information on setting up the control, see the load management information in the service manual related to the specific model.

5. Replace the covers over the load shed box and the main service entrance circuit breaker or fuse panel.
6. Reconnect the main service entrance circuit breaker or fuse.
7. Test loads. Load should be connected to the AC supply with the generator set off and be disconnected when the generator set starts.